



City of Pompano Beach

100 West Atlantic Blvd.
Pompano Beach, FL 33060

Detailed Minutes - Final

City Commission

Rex Hardin, Mayor

Beverly Perkins, Vice Mayor

Rhonda Eaton, Commissioner

Cyndy Floyd, Commissioner

Andrea McGee, Commissioner

Tom McMahon, Commissioner

Gregory P. Harrison, City Manager

Mark Berman, City Attorney

Asceleta Hammond, City Clerk

Tuesday, May 10, 2022

1:00 PM

Commission Chamber

City Commission Meeting

CALL TO ORDER

The Honorable Rex Hardin, Mayor called the Regular City Commission meeting to order at 1:00 p.m.

ROLL CALL

Present: Commissioner Rhonda Eaton
Commissioner Cyndy Floyd
Commissioner Andrea McGee
Commissioner Tom McMahon
Vice Mayor Beverly Perkins
Mayor Rex Hardin

INVOCATION

Elder Robert Kintchen of Christ Fellowship Church of God in Christ offered the invocation.

PLEDGE OF ALLEGIANCE

Led by Asceleta Hammond, City Clerk.

APPROVAL OF MINUTES

[22-369](#) Regular City Commission Meeting Minutes of April 26, 2022

A motion was made by Vice Mayor Perkins, seconded by Commissioner McGee, that the Minutes be APPROVED. The motion carried unanimously.

APPROVAL OF AGENDA

A motion was made by Vice Mayor Perkins, seconded by

Commissioner McGee, that the Agenda be APPROVED AS SUBMITTED. The motion carried unanimously.

CONSENT AGENDA DISCUSSION

The Commission may pull items from the Consent Agenda. During Audience to be Heard, a person may speak on any item on the Consent Agenda, which has not been pulled.

Mayor Hardin announced that Item(s) 1, 6, and 10 would be pulled for City Commission discussion.

A. SPECIAL PRESENTATION

[22-307](#) Legislative Update

State Senator Tina Polsky, District 29, provided a legislative update to the City Commission.

Mayor Hardin welcomed State Senator Tina Polsky, District 29, and thanked her for her service.

Senator Polsky provided a brief legislative update. She mentioned that she represents parts of North West Broward and Palm Beach in District 29. She explained the redistricting that recently took place, due to the latest census, which is done every 10 years. She will be running in the next election this November for Senate District 30, which still has some of Palm Beach, Boca Raton, and Northwest Broward in it, which she currently represents, but will be expanding into the Cities of Deerfield Beach and Pompano Beach. The Pompano section is the Northwest quadrant of Pompano Beach. She hopes to become a part of the City's legislative team in the future.

Senator Polsky mentioned that Pompano Beach has been in legislative transition due to Senator Thurston leaving with the new elections. As part of the Broward Delegation, she wanted to take this opportunity to provide a full update.

Highlights of the update were:

- 1) Home Rule - This past year there was only 1 Bill of importance in this regard, which is called the "Mother of all Preemption Bills," which she explained the purpose of Senate Bill 620.
- 2) There is a Bill that will allow the banning of smoking on beaches and parks.
- 3) Redistricting at a Special Session. They accomplished the Senate Plan, which involves her seat, completed the State House Plan, however, the Congressional Plan was incomplete. The Senate and the House voted together to hold firm on Maps they believe were constitutional, and were fair. The governor vetoed it, and indicated he did not like it, and viewed it differently. He wanted to eliminate 2 minority access seats in the State. Congressional maps are set although there is litigation, which will not be resolved before November election.
- 4) New Issues arose such as the Bills against Disney, which she mentioned briefly; is part of a special

taxing district where they provide all their own services to the people who live and visit all the Disney properties. They provide fire protection, police, utilities, water, and waste management, and in order to do this, they collect their own taxes and pay for it.

Senator Polsky stated in 2 weeks, they will return for another Special Session to deal with the property insurance crisis, which is the rising costs of the premiums and to have more providers.

Finally, Senator Polsky provided a general statement about the session. There were 250 Bills that were passed during the session, 95% of these are non-controversial, bi-partisan, many have unanimous votes, and many do good things for the citizens. Personally, she passed 5 Bills and brought back a good amount of appropriations. However, there are a small minority of Bills that were controversial, but are important, and take up a lot of time. One issue that they did not address was high rise buildings on the coast. She concluded that she would be happy to explain to anyone interested, the controversial Bills, and her reasoning for voting the way she voted on some of these Bills.

Mayor Hardin thanked Senator Polsky for the assistance her office provided to him and some of the City staff who have been there for legislative day during the session, as well as her help with the City of Pompano Beach issues. He wished her all the best and encouraged her to keep up the fight.

This matter was READ AND PRESENTED INTO THE RECORD.

B. PROCLAMATIONS

22-306 Mental Health Awareness Month

Mayor Rex Hardin proclaimed May as Mental Health Awareness Month in the City of Pompano Beach. Donna Lynn, Chair of NAMI Broward County Advocacy Group, as well as Julie Seitz, Advocate and Dr. Sandra Cumper Boynton, Executive Director accepted the proclamation. Ms. Lynn shared a brief testimony of hope written by Ms. Seitz.

Donna Lynn, Chair of the NAMI Advocacy Group of Broward, which is part of NAMI (National Alliance on Mental Illness). They are part of the nations strongest voice for people living with mental illness. She thanked the Mayor and Commissioners for providing the Proclamation to raise the awareness of mental illness. She provided a brief description and the message of the NAMI Advocacy Group.

Finally, Ms. Lynn requested permission to read a message of hope from Julie Seitz, a NAMI advocate for both Florida and Seattle, which was granted.

Mayor Hardin thanked Ms. Lynn for all that they do, and indicated that this is an important topic that more people need to pay attention to.

The Proclamation was READ AND PRESENTED INTO THE RECORD.

22-358 Emergency Medical Services Week

Mayor Rex Hardin proclaimed Emergency Medical Services Week in the City of Pompano Beach. Matthew Whitton, Assistant Chief of Emergency Medical Services, accepted the proclamation on behalf of Pompano Beach Fire Rescue.

Chad Brocato, Fire Chief, thanked the Mayor and Commissioners for their support. He announced that after this meeting, his team will be offering hands only CPR, which is part of their commitment to ensure they are ready for all events. He mentioned that the community is part of the network that save lives. This is not a certification course but a 15-minute hands on CPR. This activity is being offered in the Commission Chamber Conference room, which is provided at no cost.

This matter was READ AND PRESENTED INTO THE RECORD**22-343 National Safe Boating Week**

Mayor Rex Hardin proclaimed May 21st through May 27th, 2022 as National Safe Boating Week in the City of Pompano Beach. Mr. Harry Silverman, Flotilla Vice Commander accepted the proclamation.

Mark Brody, Division Commander for Division 3, District 7 United States Coast Guard Auxiliary, thanked the Mayor and Commissioners for granting them this Proclamation each year. He then provided a brief description of what they do and the areas they cover.

C. PRESENTATION**22-357 Annual Comprehensive Financial Report Presentation**

Presentation of the City of Pompano Beach Annual Comprehensive Financial Report, Single Audit Reports and Management Letter for the fiscal year ended September 30, 2021 and the results of the annual audit by Keefe McCullough, Independent Certified Public Accountants.

(Fiscal Impact: N/A)

(Staff Contact: Allison Feurtado)

Alison Feurtado, Acting Finance Director, stated that Florida Statutes, Chapter 218.39, requires the City to have a financial audit of its financial statements prepared by the finance staff. The City auditors, Keefe McCullough will communicate the results of fiscal year 2021 single audit.

Stephen Henry, partner with Keefe McCullough CPA firm, along with Michael Barnett another member in the CPA office that helped tremendously during the Audit. He thanked the City Commission for the opportunity to provide the independent auditing services to the City. He then provided an overhead presentation on their report.

Mayor Hardin asked Mr. Henry to explain what in the Auditing world would be considered great or not so

great.

Mr. Henry responded those would be the 2 ends of the spectrum, and the City of Pompano Beach is definitely at the great end of the spectrum.

Mayor Hardin reiterated that from an accounting standpoint the City of Pompano Beach is doing great.

Comr. McGee gave a shout out to the finance team for doing a good job, as well as management and staff who keep the City moving in a great direction all year round.

Comr. Eaton echoed Comr. McGee's sentiments. She thanked staff for doing the work to get such a good report, and she is very proud of staff.

Comr. McMahan echoed the other Commissioners' sentiments and mentioned that the finance department is doing an incredible job, and thanked them for their honest accounting audit of the City's finances. Every department within the City really does find itself in an award-winning position, which is due to the City Manager's Office and the Management Team. A shout out to the Manager and the finance team for such a great job and he thanked them for the hard work they do every day for the residents of the City.

Greg Harrison, City Manager pointed out that this makes the 10th consecutive year of clean opinions from two different auditing firms.

Vice Mayor Perkins asked for a brief synopsis on long term debts.

Mr. Henry responded that there are governmental funds and enterprise funds, with certain types of debts on each of these funds. The City has General Obligation Bonds, which these generally have the bulk of the restrictive covenants, although a lot of the other debts do as well. For an exact listing it would be listed under the Annual Comprehensive Financial Report, but the City is leveraged to a certain extent, but not so much that the debt holder would consider the City to be financially unhealthy.

Mayor Hardin thanked the City Manager for the information on the 10-year mark. Oftentimes, it is not heard from the auditors that we are in rear company as far as things go. For example, the journal entries that the auditor alluded to earlier that indicated quite a number of their clients do have those types of things. It is not bad, but the City of Pompano Beach does not have this, which is a true testament to the quality of staff and the City organization.

This matter was READ AND PRESENTED INTO THE RECORD

22-359 Update on Design Options for SE 6th Terrace Bridge Replacement

Matthew Fursetzer from Kimley-Horn Planning & Design Engineering Consultants provided an update to the Commission on alternative design options for the SE 6th Terrace Bridge replacement.

Hector Gandia, Project Manager, City Engineering Department, stated that he is the project manager for the SE 6th Terrace Bridge replacement. This will be an update provided to the City Commission on the design of the options for the bridge replacement. The designers, Kimley-Horn Planning & Design Engineering Consultants will provide a PowerPoint presentation to cover the existing bridge conditions, the current bridge design, and the potential alternative ways to increase the vertical clearance of the bridge.

Matthew Fursetzer, Kimley-Horn Planning & Design Engineering stated that the intent of the project is the replacement of the SE 6th Terrace bridge, which is 62 years old and rated as functionally obsolete. The bridge is not structurally deficient and is safe, however, improvements to the bridge are meant to improve the functional deficiencies, improve mobility and function across the bridge. He then provided an overhead presentation on the bridge as outlined in the attached **Exhibit 1**.

During Mr. Fursetzer's presentation he recommended that the proposed bridge stay at 15 miles an hour posted. He presented several alternatives that were explored regarding the replacement of the bridge. The recommended alternative would cost approximately \$5.1 million and a vertical clearance increase of 27 inches over the existing waterway.

Mayor Hardin thanked Mr. Fursetzer for his presentation and the investigation of various design options.

MOTION: A motion was made by Comr. McMahon, seconded by Comr. McGee to move forward with Alternate No. 4 and advise the City Manager's Office to come up with the funding in the next 2 years to make this project happen. The motion carried unanimously.

Comr. McMahon indicated that putting in a bridge is something that may be done every 50 years, so this is not something done every 20 years. This will provide tremendous benefit to the hundreds of residents that live behind the bridge. This was done with the 5th Avenue bridge and there are plans to do this with the McNab bridge. He would like to see the City move forward with this to provide that extra height, and provide a safer channel with 2 navigational channels to go through.

Mayor Hardin added that it is not just the boating public that will benefit, rather it will be a gateway to all of the homes that lie anywhere in the vicinity of any of the bridges within the City. It is an enhancement to the curb appeal of the City.

Alison Fournier, 430 SE 6th Avenue, Pompano Beach, FL, thanked the City Commission for looking into this. She mentioned that they had expressed some concern at a meeting in February about the letter received from the Coast Guard. This is an important issue to a lot of residents, and beautification of the City includes the neighborhoods and not just the beaches or Old Town.

Continuing, Ms. Fournier indicated that she would want to help to find the money. Conveniently, there is approximately \$3 million of value created through incremental property taxes for doing this. If a modest increase was assumed in home values of about \$25,000 for the incremental height the amount could be realized. In addition, Ms. Fournier mentioned that she had more input from other people in the neighborhood who had thoughts on this, as well as the sea level rise, and a smaller amount would not be enough over time, and especially since the bridge will outlive everyone present.

Chris Cressman, SE 2nd Avenue, Pompano Beach, FL, spoke in favor of the motion to select alternative 4, and provided his reasons and agrees with the first speaker Ms. Fournier that the rise in property values will increase the tax base and help to offset the cost for this project.

Daniel Beitra, 210 SE 3rd Avenue, Pompano Beach, FL, spoke in favor of the motion to select alternative 4, and provided his reasons. He expressed his appreciation of Comr. McMahon and the other members of the Commission listening to the residents on this matter.

Comr. McMahon added that the City would conduct multiple public meetings similar to what has been done with the 5th Avenue bridge and other bridges. These meetings will get the input of the type of art work, the type of entrance, the type of lighting, and things of that nature.

Comr. McGee echoed Comr. McMahon's comments and indicated that they should ensure that it represents the neighborhood where it is located, and that they have the input of residents on the design, the art, and any type of traffic calming and all that would be necessary.

Vice Mayor Perkins expressed her pleasure to see the residents expressing their happiness with the bridge. If there are any updates or progress on the bridge, she suggested putting this also on the 6:00 p.m. City Commission Agenda for those residents that are not in attendance at this meeting.

Comr. Eaton indicated that because it is so rare that this is done, which is typically every 50-60 years, it is a good long-term investment for the City.

This matter was READ AND PRESENTED INTO THE RECORD

D. AUDIENCE TO BE HEARD

Mayor Hardin announced that it was time for "Audience To Be Heard" and offered the following guidelines: Once your name is called, please come forward to the podium in front of the commission, state your name and address for the record. Speakers will be limited to three minutes to speak on any item of concern or interest, including those items pulled from the Consent Agenda. In addition, he asked speakers not to speak on any items on tonight's agenda, as they will have that opportunity to do so when that item comes forward. Lastly, he requested that speakers refrain from any emotional outbursts in either support or non-support of the speaker's comments.

The following persons were called to speak:

Individual Websites for Elected Officials - Vicente Thrower, 1890 NW 6th Avenue, Pompano Beach, FL, repeated his suggestion to have individual websites set up for the elected officials. For example, it would be good for Mayor Hardin to have a website that actually promotes and provides information on the bridge project that was just recently discussed. He understands the current website provides a bio as well as the email addresses of the Commission, but it does not provide information on the various events that the individual Commission members attend or plan to attend. He mentioned that the purpose of having the individual websites

would be to engage the constituents and to inform them of what they are doing. He mentioned that County Commissioner Lamar Fisher has a subscription website, where on his page a person can subscribe to all his notifications, so when he is speaking on a certain subject matter, such as rental assistance or property appraiser issues it is easily accessible. He said just having a bio and an email address is not sufficient for the individual elected body.

Additional Lobbyists - Mr. Thrower enquired about hiring additional lobbyists to ensure the governor is friendly and that the City is receiving its necessary appropriations. He complained that the City continues to have the same lobbying group, which may not be feasible as to how much is being paid to them versus how much money they have delivered. He is hoping the City would look for additional bi-partisan lobbying firms who will get things done instead of having so many items vetoed by the Governor.

Vice Mayor Perkins indicated that she checked into the Broward County website to which Mr. Thrower cited earlier that the City could pattern, and felt the City could give this effort a try, especially when she has been confronted by numerous persons asking her what she is doing in her District, as well as what is taking place in the District. She posts events to her personal Facebook page, but few people see that. For example, earlier today, Mayor Hardin, Comr. Eaton, Comr. McMahon and she attended the Women's event, which she put on her Facebook page but few people can see that they were attending the event. Therefore, she believes it is a good idea to consider a website page to better inform the public of events taking place in the City.

Mayor Hardin agreed and indicated that Comr. Floyd has been in contact with Sandra King, Strategic Communication Director regarding this same matter. He believes staff would be able to work on these kinds of issues.

Comr. McGee suggested a possible solution for this issue, if everyone has a professional Facebook page that they are using, perhaps staff could look into adding a widget for a web feed, if it is legally allowed, and does not violate campaign finance situations to embed a widget that would allow the Commission to post a picture to their Facebook, and have it on their personal Bio page without the creation of another landing zone or a separate web domain altogether. In other words, the Commission is bound to campaign finance laws during election years, and it could be misconstrued if they are posting an event to your Facebook page or a website that is tied directly to the City's website, which could lead to gray areas, which legal would have to approve this is permissible, prior to moving too far in that direction.

Mayor Hardin agreed it is a good point, but the question is excellent regarding if this is legal. Anything the Commission does, they have to be careful in what they participate in the City.

A discussion among the Mayor and the Commissioners followed regarding the feasibility of setting a specific web page or pages to inform the constituents in each District within the City. The final decision was for each Commission to meet with staff to get more information on this matter.

Audience conduct in the Chamber - Carlene Duncan, 1851 NW 15th Street, Pompano Beach, FL, asked the Mayor for what reason is the Commission meeting.

Mayor Hardin responded to conduct the City's business.

Ms. Duncan complained that 2 months ago there were people in the audience that she felt the Commission did not listen to them. However, at this current meeting, they listened to the audience, and this is how it should be. She also has an issue with being told not to clap her hands in the meeting, and indicated that if somebody says something, she will be clapping.

Home Rehab Program - Marian Donnell, 2150 NW 4th Street, Pompano Beach, FL, stated that she has been participating in the Home Rehab program and the contractor was hired to come out to her home. She applied for the Rehab program, but it was switched over to the Weatherization program, which she was told would have been better. After the completion of her home, her house was in worse shape than it was prior to the contractors coming in. She complained that mold is sitting in the windows, however, whenever she tried to speak to someone about this, they asked her why she waited so long to report this. She has spoken to several persons about this problem but no one seems to be able to assist her with getting the issues involved corrected.

Mayor Hardin asked if this is through the Office of Housing and Urban Improvement (OHUI) department, and directed the City Manager to check into the situation.

Greg Harrison, City Manager, responded that he did receive some information from Ms. Donnell in order to find a source to assist her.

Vice Mayor Perkins stated that she sympathizes with Ms. Donnell and has spoken with her several times on the phone. Notwithstanding, she has received several complaints and concerns about the department regarding Rehab and Weatherization programs. She thanked Ms. Donnell for coming out to bring this to the City Commission's attention.

Mayor Hardin asked the City Manager to provide a report to the Commission on Ms. Donnell's issues.

Mr. Harrison mentioned that if Vice Mayor Perkins receives complaints she could make that known, because he has not received any complaints from her.

Vice Mayor Perkins stated that she has been speaking with Assistant City Manager Earl Bosworth on one or two of the same complaints. She does not want the residents to be frustrated when they are trying to get things done in their homes, which is a sensitive issue.

Comr. Eaton mentioned that the County has a fund available for residents who can qualify or quantify poor workmanship or contractor who fail to uphold their duties. A person can apply for help to make homeowners' home whole again, and the information can be found on the County's Board of Rules and Appeals website.

Issues with McNab Park - Alison Fournier, 430 SE 6th Avenue, Pompano Beach, FL, spoke about McNab Park in particular SE 2nd Street. The East-West Street on the southside of the park, which is a heavily traveled road for people who live in Snug Harbor, Garden Isles, Norwood, and Cypress Harbor. These residents use this road to get to the beach whether by running, biking, golf carting and driving, which is south of Atlantic Boulevard. Several years ago, the Commission voted to move the McNab House and turn that area into a garden, which eliminates the tennis court, the basketball court and the playground. It has been 2 years, and

since that time, the south side part of the park has been left in disrepair. Except for the tennis court, it is of little use to the residents. She received a text from a friend who was running in that area and encountered a needle/syringe in the street, adjacent to the playground. This is not an uncommon occurrence for that area, a month ago, it was looking better, but it appears to have fallen back into a bad situation again.

Continuing, Ms. Fournier enquired about the plans for maintaining that part of the park and road for the next year or two, because currently it is a dangerous stretch of the road and embarrassing. Also, she asked about the opening of the 5th Avenue bridge.

Comr. McMahon responded that the 5th avenue bridge is scheduled to open next week.

Mayor Hardin mentioned that the City Manager will have the Public Works department take a look at the McNab Park to police it and ensure it is cleaned up in that area. He also noted that no decision has been made for the south side of that park as far as what will happen to the park facility.

Comr. McMahon stated that the tennis court near the park has not been completely eliminated from the plan. The City has purchased land around the park that some of those facilities will probably be moved there. He also mentioned that he drove by the park and he saw the same conditions. There are a number of vagrants and homelessness going on in the park, so he will ask the Broward Sheriff's Office of the Homeless Outreach team to spend a little more time there, as well as to have the Park Rangers monitoring the park and to be seen there. He thanked Ms. Fournier for bringing this matter to the City Commission's attention.

E. CONSENT AGENDA

Mayor Hardin requested a motion to Approve/Adopt Items 2-5, and 7-9 without City Commission discussion.

A motion was made by Commissioner McGee, seconded by Commissioner Eaton, that the Consent Agenda be APPROVED/ADOPTED. The motion carried unanimously.

1. [22-344](#) Approve ranking order for RLI E-07-22 Continuing Contract for Marine Engineering Services, and authorize staff to enter into contracts with the three highest-ranked companies: Sea Diversified, Inc., Aptim Environmental & Infrastructure, LLC, and Cummins Cederberg, Inc. (No cost at this time.) (Fiscal Impact: N/A)

(Staff Contact: John Sfiropoulos)

Vice Mayor Perkins asked to pull the item for City Commission discussion, and stated that the backup indicated this is a contract for the City and the Community Redevelopment Agency (CRA), and enquired if this consisted of both the East and West CRA's.

John Sfiropoulos, City Engineer, responded yes. Also, he confirmed it is a 5-year contract not to exceed \$4

million. However, there is no cost at this time, because this is just to rank the companies. At a later date, the actual contracts will be forthcoming.

A motion was made by Vice Mayor Perkins, seconded by Commissioner McGee, that the Consent Agenda/ Approval Request be APPROVED. The motion carried by the following vote:

Yes: Eaton
Floyd
McGee
McMahon
Perkins
Hardin

2. [22-348](#) Approve ranking order for RLI E-10-22 Continuing Contracts for Airpark Engineering Services, and authorize staff to enter into contracts with the two responsive and responsible companies: HDR Engineering, Inc., and Kimley-Horn and Associates, Inc. (No cost at this time)
(Fiscal Impact: N/A)

(Staff Contact: John Sfiropoulos/Steven Rocco)

A motion was made by Vice Mayor Perkins, seconded by Commissioner McGee, to APPROVE/ADOPT the item under the Consent Agenda. The motion carried unanimously.

3. [22-349](#) Approve ranking order for RFP T-02-22, Beach Equipment Concession, and authorize staff to negotiate a contract with the highest-ranked company, Boucher Brothers Management, Inc.
(Fiscal Impact: No cost at this time)

(Staff Contact: Mark Beaudreau)

A motion was made by Vice Mayor Perkins, seconded by Commissioner McGee, to APPROVE/ADOPT the item under the Consent Agenda. The motion carried unanimously.

4. [22-347](#) Approve ranking order for RFP T-01-22, Repairs and Calibration of Flow Meters and Related Devices, and authorize staff to negotiate contract with the highest-ranked company, PC Controls, Inc.
(Fiscal Impact: (No cost at this time.)

(Staff Contact: A. Randolph Brown)

A motion was made by Vice Mayor Perkins, seconded by Commissioner McGee, to APPROVE/ADOPT the item under the Consent Agenda. The motion carried unanimously.

5. [22-356](#) A RESOLUTION OF THE CITY COMMISSION OF THE CITY OF POMPANO BEACH, FLORIDA, APPROVING THE CITY'S FISCAL SUSTAINABILITY PLAN FOR THE GATEWAY DRIVE STORMWATER IMPROVEMENTS PROJECT, RELATING TO THE FLORIDA DEPARTMENT OF ENVIRONMENTAL PROTECTION (FDEP) STATE REVOLVING FUND (SRF); PROVIDING AN EFFECTIVE DATE.

(Fiscal Impact: N/A)

(Staff Contact: A. Randolph Brown)

A motion was made by Vice Mayor Perkins, seconded by Commissioner McGee, to APPROVE/ADOPT the item under the Consent Agenda. The motion carried unanimously.

Enactment No: RES. No. 2022-133

6. [22-215](#) A RESOLUTION OF THE CITY COMMISSION OF THE CITY OF POMPANO BEACH, FLORIDA, APPROVING AND AUTHORIZING THE PROPER CITY OFFICIALS TO EXECUTE AN APPROPRIATIONS CONTRACT BETWEEN THE CITY OF POMPANO BEACH AND BROWARD COUNTY SHERIFF'S OFFICE TO SUPPORT THE SUMMER G.R.E.A.T. PROGRAM IN PREVENTING YOUTH VIOLENCE, GANG PARTICIPATION, ANTI-BULLYING AND THEIR LEGAL CONSEQUENCES; PROVIDING AN EFFECTIVE DATE.

(Fiscal Impact: \$15,000.00)

(Staff Contact: Erjeta Diamanti)

Vice Mayor Perkins asked to pull the item for City Commission discussion, and stated that her concerns were that the City funds this program every year from the General Fund, but she has never received any update or progress report as to the effectiveness of the program. She enquired if these are residents of Pompano Beach. As referenced in the backup material, it states, "...violent prevention, and build trust between law enforcement and the community." So, are these students or young people just from the Pompano Beach area.

Erjeta Diamanti, Budget Director, responded that this is an annual program that is being funded from the General Fund. It is serving Pompano Beach Middle School children, and each year, approximately 35-40 students participate in this program. The students usually come from low income families, and the statistics show that they are African-Americans. In addition, the City receives from the Broward Sheriff's Office (BSO) an annual report on the results of the program, which is received in September. However, she will be able to forward last year's report to the City Commission.

Major Wayne Adkins, Chief of Police, BSO, reported that Vice Mayor Perkins' concerns are valid. He will have Captain Stallings, who has been part of this great program when he was a School Resource Officer (SRO) at Sanders Park and other schools, to explain more on what this mentoring program does.

Continuing, Major Adkins stated that each year he does a presentation, he would extend an invitation to the Commission to come and speak to the children to talk about their experiences serving on the Commission and being in business. The program is geared towards mentoring children.

Captain Darryl Stallings, Area 2 Captain, stated that this is a GREAT (Gained Resistance Education and Training) program. The program is Broward County School-based, and is taught to mostly 5th graders but it does extend to 3rd graders through to Kindergarten. This teaches kids about peer pressure, and gang prevention. They choose about 40 kids to participate, and they meet with the parents, conduct field trips and invite guest speakers. Since he came back he has not had the chance to talk to the kids due to the pandemic. However, he plans to speak with them about his background and upbringing. The speakers that are brought in, must have something to offer the Pompano Beach neighborhood kids, and they teach them about life skills. The Fire Department is invited to come in and teach them life saving skills as well as CPR.

Vice Mayor Perkins indicated that she is aware that Captain Stallings does a good job because he connects with the community quite well. However, she thinks some of the things that are being done need to be put out there on the City's website so everyone can know what is actually being done and how effective it is. She mentioned that as an educator, she has seen where kids in Elementary School love police officers, however, when they get to Middle School something changes and that love is no longer there. Therefore, she would love to see him work more with Middle School kids.

Comr. McMahon echoed Vice Mayor Perkins' comments that sharing the story of what BSO does in Pompano Beach is something that they will need to work a little harder on. Day in and day out, there are some incredible people that work for the Sheriff's Office providing great service to the residents. Somehow this needs to be communicated to the residents. If BSO has their own Facebook page for Pompano Beach or they could work with the Pompano Beach's communication's team to tell residents what is being done, that would be a good effort. Not only are there gifted officers, but they are dedicated to the residents of the City. Since he has been elected, he has not received a complaint about the Sheriff's Office, which is hard to believe. They provide great service so there is a need to show what they are doing.

Comr. McGee also echoed that everyone should be made aware of the programs, and people be encouraged to sign up for it. Perhaps, they could reach out to staff to do something similar to the short video series done about the different art installations and things. There could be a 30 second snippet of the different programs that are offered throughout the City. This perhaps would generate interest for those people who are not aware of the programs being offered by the City, and those who want to get involved in mentorship.

Comr. Floyd agreed with her fellow Commissioners and would like to be included in the loop of the information being shared about this program. She enquired if there is a flyer on this could that be emailed to her so she can put it on her Facebook page so people in the neighborhood can get their kids registered for it. This would be a great program to add to the individual webpages of the Commission.

Comr. Eaton thanked BSO for their service and noted that it is a great program, and she is glad to approve funding for it.

A motion was made by Vice Mayor Perkins, seconded by

Commissioner McGee, that the Consent Agenda/ Resolution be ADOPTED. The motion carried by the following vote:

Yes: Eaton
Floyd
McGee
McMahon
Perkins
Hardin

Enactment No: RES. No. 2022-134

7. [22-332](#) A RESOLUTION OF THE CITY COMMISSION OF THE CITY OF POMPANO BEACH, FLORIDA, APPROVING AND AUTHORIZING THE PROPER CITY OFFICIALS TO EXECUTE A 2022 AMENDMENT TO THE INTERLOCAL AGREEMENT BETWEEN BROWARD COUNTY AND THE CITY OF POMPANO BEACH PROVIDING FOR DIVISION AND DISTRIBUTION OF THE PROCEEDS FROM THE BROWARD COUNTY ADDITIONAL THREE CENT LOCAL OPTION GAS TAX ON MOTOR FUEL; PROVIDING AN EFFECTIVE DATE.

(Fiscal Impact: N/A)

(Staff Contact: Erjeta Diamanti)

A motion was made by Vice Mayor Perkins, seconded by Commissioner McGee, to APPROVE/ADOPT the item under the Consent Agenda. The motion carried unanimously.

Enactment No: RES. No. 2022-135

8. [22-333](#) A RESOLUTION OF THE CITY COMMISSION OF THE CITY OF POMPANO BEACH, FLORIDA, APPROVING AND AUTHORIZING THE PROPER CITY OFFICIALS TO EXECUTE A 2022 AMENDMENT TO THE INTERLOCAL AGREEMENT BETWEEN BROWARD COUNTY AND THE CITY OF POMPANO BEACH PROVIDING FOR DIVISION AND DISTRIBUTION OF THE PROCEEDS FROM THE BROWARD COUNTY FIFTH CENT ADDITIONAL LOCAL OPTION GAS TAX ON MOTOR FUEL FOR TRANSIT; PROVIDING AN EFFECTIVE DATE.

(Fiscal Impact: N/A)

(Staff Contact: Erjeta Diamanti)

A motion was made by Vice Mayor Perkins, seconded by Commissioner McGee, to APPROVE/ADOPT the item under the Consent Agenda. The motion carried unanimously.

Enactment No: RES. No. 2022-136

9. [22-324](#) A RESOLUTION OF THE CITY COMMISSION OF THE CITY OF POMPANO

BEACH, FLORIDA, APPROVING AND AUTHORIZING THE PROPER CITY OFFICIALS TO EXECUTE A FDOT DISTRICT FOUR (4) AMENDMENT NUMBER TWENTY-TWO (22) TO INCLUSIVE LANDSCAPE MAINTENANCE MEMORANDUM OF AGREEMENT BETWEEN THE CITY OF POMPANO BEACH AND THE STATE OF FLORIDA DEPARTMENT OF TRANSPORTATION, TO ADD ADDITIONAL LANDSCAPE IMPROVEMENTS ON STATE ROAD A1A (OCEAN BLVD.) BETWEEN SUNSET LANE AND ATLANTIC BLVD.; PROVIDING AN EFFECTIVE DATE.

(Fiscal Impact: N/A)

(Staff Contact: Robert McCaughan)

A motion was made by Vice Mayor Perkins, seconded by Commissioner McGee, to APPROVE/ADOPT the item under the Consent Agenda. The motion carried unanimously.

Enactment No: RES. No. 2022-137

10. [22-210](#) A RESOLUTION OF THE CITY COMMISSION OF THE CITY OF POMPANO BEACH, FLORIDA, APPROVING AND AUTHORIZING THE PROPER CITY OFFICIALS TO EXECUTE A SECOND AMENDMENT TO THE DEVELOPER'S AGREEMENT BETWEEN THE CITY OF POMPANO BEACH AND HABITAT FOR HUMANITY OF BROWARD, INC. RELATING TO THE DEVELOPMENT OF THE PROPERTY LOCATED AT THE SOUTHWEST CORNER OF NW 6TH AVENUE AND NW 15TH STREET; PROVIDING AN EFFECTIVE DATE.

(Fiscal Impact: N/A)

(Staff Contact: Daniel Keester-O'Mills/David Recor)

Vice Mayor Perkins asked to pull the item for City Commission discussion and enquired if the City will be reducing the number of homes. Originally, it was going to be 77 Habitat homes, which is being reduced to 76 and she asked if one extra lot will be available for a City playground. Also, she wanted to know if this would be in the same areas where the homes are located.

Daniel Keester-O'Mills, Principal Planner, Development Services Department, responded yes, the development agreement that is represented in this item, Nancy Robin from Habitat for Humanity of Broward asked to reduce the number of homes from 77 to 76. There is one Park already developed, so this one will be on the opposite side of that development. Therefore, it will be on a new lot and it will be a smaller park from the one already set up there. The idea is to make it into a passive park.

Vice Mayor Perkins indicated that she liked the idea of putting in a passive park.

Vicente Thrower, 1890 NW 6th Avenue, Pompano Beach, FL, asked if this will be a City Park. He complained that someone had broken the gate and brought their dog through. He wanted to know who would be responsible for these kinds of things to ensure its upkeep. On the other hand, he wanted to ask about the

wood chips in these parks for the children to play in, which they need to ensure that they are not affected. Also, the park is at the corner near a gas station that has a history of violence, killing, drugs, and everything else.

Vice Mayor Perkins mentioned that she checked into the wood chips in the Park and found out that it is safe for the kids to play in.

Sarahca Peterson, 145 SW 7th Terrace, Pompano Beach, FL, stated that as a mother who has a 2-year-old son, wood chips are not safe. She said she has had to take him to the doctor because of splinters, he puts the chips in his mouth. Dogs can defecate in it, so it is not as safe as the turf would be in that area. There could be an alternative to wood chips being in that community and that park.

Nancy Robin, Habitat for Humanity of Broward, Inc., 888 West Cypress Creek Boulevard, Fort Lauderdale, FL, thanked the Commission for their support for affordable workforce housing in Pompano Beach. In this case, she does not think a developer would request more green space in a development. The park has not yet been designed so there is no discussion about wood chips. Nevertheless, it is helpful to hear the opinions, and will work with the Community to figure the best quality of space for the area.

A motion was made by Vice Mayor Perkins, seconded by Commissioner McGee, that the Consent Agenda/ Resolution be ADOPTED. The motion carried by the following vote:

Yes: Eaton
Floyd
McGee
McMahon
Perkins
Hardin

Enactment No: RES. No. 2022-138

F. REGULAR AGENDA

QUASI-JUDICIAL PROCEEDING

Mark E. Berman, City Attorney, advised that Item 11 is listed under Quasi-Judicial Proceeding and is quasi-judicial in nature; therefore, anyone who wishes to testify must be sworn in and may be subject to cross-examination by the City Commission or any other interested party. The individuals addressing the City Commission must state his or her name, whether he or she has been sworn, and understands the rules which governs these proceedings. Thereafter, Mr. Berman outlined the order in which they would follow: City staff would make its presentation for each item, followed by the applicant or any other person(s) wishing to speak, closing argument, and the Commission's discussion.

Asceleta Hammond, City Clerk, placed under oath all individuals, including staff, addressing the City Commission in the following matters.

11. [22-345](#) A RESOLUTION OF THE CITY COMMISSION OF THE CITY OF POMPANO BEACH, FLORIDA, APPROVING AND AUTHORIZING CITY STAFF'S LETTER OF NO OBJECTION TO AMENDMENT OF NOTATION ON THE P.B.P.F. PLAT; PROVIDING AN EFFECTIVE DATE.

(Fiscal Impact: N/A)

(Staff Contact: Jean Dolan/David Recor)

Jean Dolan, Development Services Department, presented the item and stated that this is a City initiated request for Plat Note Amendment to the P.B.P.F. Plat. The subject property is located at 100 SW 3rd Street, which is on the SE corner of the FEC Railroad corridor and SW 3rd Street, aka Racetrack Road and Chris Reyka Place. The Plat Note Amendment will change the Plat Note from 55,950 square feet of government facility to 140,000 square feet of government facility to accommodate construction of the new Fire Rescue and Emergency Operations Center facility being funded by the G.O. Bond. On March 2022, the Site Plan for the facility was unanimously approved by the Planning and Zoning Board and the Plat Note Amendment Resolution is authorizing staff to sign a Letter of no Objection for this request.

Meeting went into Recess

A motion was made by Vice Mayor Perkins, seconded by Commissioner McGee, that the Quasi-Judicial/ Resolution be ADOPTED. The motion carried by the following vote:

Yes: Eaton
Floyd
McGee
McMahon
Perkins
Hardin

Enactment No: RES. No. 2022-139

END OF QUASI-JUDICIAL PROCEEDING

12. [22-350](#) Approval to award ITB E-11-22 Construction of Pompano Beach Airpark Parcel Y Access Road and Utility Service, to the lowest responsive, responsible bidder, Lanzo Construction Co., Florida, dba Lanzo Construction Company, at a cost of \$538,427.00.

(Fiscal Impact: \$538,427.00)

(Staff Contact: Steven Rocco)

Meeting Reconvened

Tammy Good, CIP Manager, presented the item and stated that the project consists of constructing an access road with underground utilities to the Air Park. The procurement process included a competitive solicitation of which Lanzo Construction Company was the lowest responsive bidder. Staff seeks to award the contract to the lowest responsive bidder. After checking the references staff is confident that they can perform the services. In addition, 50% of the construction costs is funded by Florida Department of Transportation (FDOT).

A motion was made by Vice Mayor Perkins, seconded by Commissioner McGee, that the Regular Agenda/ Approval Request be APPROVED. The motion carried by the following vote:

Yes: Eaton
Floyd
McGee
McMahon
Perkins
Hardin

13. [22-335](#) A RESOLUTION OF THE CITY COMMISSION OF THE CITY OF POMPANO BEACH, FLORIDA, RESCINDING RESOLUTION NO. 2022-66, AND APPROVING AND AUTHORIZING THE PROPER CITY OFFICIALS TO EXECUTE A FIRST AMENDMENT TO THE INTERLOCAL AGREEMENT BETWEEN BROWARD COUNTY AND THE CITY OF POMPANO BEACH RELATING TO THE BROWARD COUNTY, SEGMENT II, SHORE PROTECTION PROJECT; PROVIDING AN EFFECTIVE DATE.

(Fiscal Impact: \$2,250,000 paid in 3 equal payments of \$750,000 each November beginning November 2022)

(Staff Contact: Robert McCaughan)

Robert McCaughan, Director, Public Works Department, presented the item and stated that this is requesting the City Commission to rescind the Resolution approved in January. At the request of Broward County, they want to revise a text change of the Resolution, however, there is no change to the conditions, the amount of money or when it becomes due. To get on the record this had to be brought back to the City Commission as a new Resolution. This is strictly administrative in nature and there are no changes to the Terms and Conditions.

Comr. McGee thanked everyone involved in this renourishment. It has been quite the change and you can see that this has made our beach quite beautiful.

Mayor Hardin asked if this was a text change on behalf of the County.

Mr. McCaughan responded that is correct. He explained that the County felt the language was not clear enough and explained the circumstance of the change.

A motion was made by Vice Mayor Perkins, seconded by Commissioner McGee, that the Regular Agenda/ Resolution be ADOPTED. The motion carried by the following vote:

Yes: Eaton
Floyd
McGee
McMahon
Perkins
Hardin

Enactment No: RES. No. 2022-140

14. [22-354](#) A RESOLUTION OF THE CITY COMMISSION OF THE CITY OF POMPANO BEACH, FLORIDA, APPROVING AND AUTHORIZING THE PROPER CITY OFFICIALS TO APPLY FOR THE STATE OF FLORIDA DEPARTMENT OF ENVIRONMENTAL PROTECTION REVOLVING LOAN PROGRAM FOR WASTEWATER FACILITIES; PLEDGING OF WATER AND SEWER UTILITY FEES AS THE REVENUES TO REPAY THE LOAN, PROVIDING FOR CONFLICTS, PROVIDING FOR SEVERABILITY; PROVIDING AN EFFECTIVE DATE.
(Fiscal Impact: \$2,882,108 Financed over the maximum SRF 20-Year term with Water and Sewer Revenues)

(Staff Contact: A. Randolph Brown)

A. Randolph Brown, Director, Utilities Department, presented the item and stated this is a request for a loan application for the City's largest unsewered area that is remaining. It is 51 acres and they are removing 79 septic tanks in this project. This will improve the economic development of the properties there with a central sewer system in place, as well as improve the environment.

A motion was made by Vice Mayor Perkins, seconded by Commissioner McGee, that the Regular Agenda/ Resolution be ADOPTED. The motion carried by the following vote:

Yes: Eaton
Floyd
McGee
McMahon
Perkins
Hardin

Enactment No: RES. No. 2022-141

15. [22-355](#) A RESOLUTION OF THE CITY COMMISSION OF THE CITY OF POMPANO

BEACH, FLORIDA, APPROVING AND AUTHORIZING THE PROPER CITY OFFICIALS TO APPLY FOR THE STATE OF FLORIDA DEPARTMENT OF ENVIRONMENTAL PROTECTION REVOLVING LOAN PROGRAM FOR STORMWATER FACILITIES; PLEDGING OF STORMWATER UTILITY FEES AS THE REVENUES TO REPAY THE LOAN, PROVIDING FOR CONFLICTS, PROVIDING FOR SEVERABILITY; PROVIDING AN EFFECTIVE DATE.

(Fiscal Impact: \$1,840,250 Financed over the maximum SRF 20-year term with Stormwater Revenues.)

(Staff Contact: A. Randolph Brown)

A. Randolph Brown, Director, Utilities Department, presented the item and stated this State Revolving Loan (SRF) application is for a stormwater program for finger canal streets. The water will be collected and discharged into the intercoastal, which will reduce some of the flooding on those streets.

A motion was made by Vice Mayor Perkins, seconded by Commissioner McGee, that the Regular Agenda/ Resolution be ADOPTED. The motion carried by the following vote:

Yes: Eaton
Floyd
McGee
McMahon
Perkins
Hardin

Enactment No: RES. No. 2022-142

16. [22-304](#) **P.H. 2022-56: (PUBLIC HEARING 2ND READING)**

AN ORDINANCE OF THE CITY COMMISSION OF THE CITY OF POMPANO BEACH, FLORIDA, APPROVING AND AUTHORIZING THE PROPER CITY OFFICIALS TO EXECUTE AN AGREEMENT BETWEEN THE CITY OF POMPANO BEACH AND THE SCHOOL BOARD OF BROWARD COUNTY, FLORIDA, PROVIDING FOR THE USE OF SCHOOL BUSES FOR CITY RECREATIONAL PURPOSES; PROVIDING FOR SEVERABILITY; PROVIDING AN EFFECTIVE DATE.

(Fiscal Impact: N/A)

FIRST READING: APRIL 26, 2022

(Staff Contact: Mark A. Beaudreau)

Mark Beaudreau, Recreation Programs Administrator, presented the item and stated that this is the Second Reading of the Ordinance and there are no additional comments.

A motion was made by Vice Mayor Perkins, seconded by Commissioner McGee, that the Regular Agenda/ Ordinance be ADOPTED. The motion carried by the following vote:

Yes: Eaton
Floyd
McGee
McMahon
Perkins
Hardin

Enactment No: ORD. No. 2022-46

17. [22-351](#) **P.H. 2022-59: (PUBLIC HEARING 1ST READING)**
AN ORDINANCE OF THE CITY COMMISSION OF THE CITY OF POMPANO BEACH, FLORIDA, AMENDING CHAPTER 100, "STREETS AND SIDEWALKS," OF THE CITY OF POMPANO BEACH CODE OF ORDINANCES BY AMENDING SECTION 100.01, "MINIMUM RIGHT-OF-WAY," TO PROVIDE EXCEPTIONS FOR REQUIRED RIGHT-OF-WAY WIDTH IN CERTAIN DESIGNATED AREAS, AND AMENDING CHAPTER 155, "ZONING CODE," OF THE CITY OF POMPANO BEACH CODE OF ORDINANCES BY AMENDING SECTION 155.5704., "FRONTAGE AND ACCESS," TO PROVIDE FOR SPECIFIC UTILITY AND PUBLIC SAFETY ACCESS REQUIREMENTS FOR PROPERTIES IN CERTAIN DESIGNATED AREAS; PROVIDING FOR SEVERABILITY; PROVIDING AN EFFECTIVE DATE.
(Fiscal Impact: TBD)

(Staff Contact: Jean Dolan/John Sfiropoulos)

Jean Dolan, Development Services Department presented the item and stated that the proposed Text Amendment is to recognize 2 areas in the Northwest community that currently do not have public roads or dedicated utility easements. These areas are north of NW 15th Street between NW 17th Avenue and NW 19th Avenue, and north of NW 15th Court between North Andrews Avenue and NW 16th Avenue. Lots were created in these areas but were never formally platted, so code compliant 50-foot road dedications and utility easements were not consistently dedicated. Several of the lots were allowed to be developed without access to code required roadways. Access to the properties in these areas are via dirt tracks that are primarily informal and cut through private property. Over the past years, a development pattern has emerged that now precludes the development of 50-foot wide code required roads. A plan has been prepared that will accommodate 30-foot wide roads, which is the minimum required to provide access to the currently land-locked and unbuildable lots. Due to the need to use narrower right-of-ways, sidewalks will not be included in the cross-section, and no parking will be allowed in the future right-of-way to ensure access by fire and garbage trucks. This item is identified in the Strategic Plan as Item 4.3.18 in the Action Agenda under Management in Progress for fiscal year 2022-2023. The next step after this is to actually acquire the right-of-ways, right to legal descriptions in order to implement the road plans within the area.

Finally, Ms. Dolan indicated that the City Engineers, along with the City Property Manager, are available for questions.

Carlene Duncan, 1851 NW 15th Street, Pompano Beach, FL, enquired about what is being done on NW 15th Street, and asked will her property be affected.

Ms. Dolan responded that nothing is being done on 15th Street. This is a County right-of-way and is already fully acquired. She explained that they have positioned the proposed new roads in such a way that it will not affect her property. All the right-of-ways will be dedicated from her neighbor from the west.

Irie Herbert, 2750 NW 3rd Street, Pompano Beach, FL, spoke in support of the Ordinance. He would appreciate if the Commission would pass this Ordinance because the land has been land-locked for years and the owner has not been able to build or do anything. In addition, he indicated that he owns a piece of property in the area and has agreed to give up a percentage of his land for this project so that it will become a beautiful location for homes to be built in the area.

Vice Mayor Perkins stated that this is a good idea to pave those roads in that area around Markham. The City became a town in 1908 and became incorporated as a City in 1947, since that time those roads have not been paved and the residents have been asking for roads for many years.

Ms. Dolan explained that there are no roads in the area, rather they are dirt tracks that goes through private properties. So, the City is trying to acquire the right-of-way through either dedications, easements or purchase so roads can be created to be paved. As it is, no roads can be paved because these are all on private properties. So, they are tracks not roads.

Vice Mayor Perkins suggested that perhaps something could be worked out with the owners, because they would want to work with the City so they can ride down a road that is not dirt. The area will eventually be developed, so now is a good time to pave the roads.

Mayor Hardin thanked Mr. Herbert for participating in the process and hopefully they will be able to negotiate with all the property owners to make this happen sooner rather than later. This is something that should have been done a long time ago, but they are just getting around to do it. This is a step to get the City there.

A motion was made by Vice Mayor Perkins, seconded by Commissioner McGee, that the Regular Agenda/ Ordinance be APPROVED FIRST READING. The motion carried by the following vote:

Yes: Eaton
Floyd
McGee
McMahon
Perkins
Hardin

18. [22-365](#) A RESOLUTION OF THE CITY COMMISSION OF THE CITY OF POMPANO BEACH, FLORIDA, APPOINTING KATHERYN GILLIS TO THE AIR PARK ADVISORY BOARD OF THE CITY OF POMPANO BEACH FOR A TERM OF THREE (3) YEARS; SAID TERM TO EXPIRE ON MAY 27, 2025; PROVIDING AN EFFECTIVE DATE.

(Fiscal Impact: N/A)

APPLICANTS:

Katheryn Gillis, **Incumbent** - District 4

Nancy Grant, **Incumbent** - District 5

Frank Sellers, Jr. - District 3

(**Staff Contact:** Asceleta Hammond)

Vice Mayor Perkins indicated that she checked with City Attorney Berman if there would be any voting conflict since she is related to Ms. Katheryn Gillis, and understands there is no conflict.

Mark Berman, City Attorney explained that there is no ethical issues with this matter, there is no special gain that will be realized and nothing wrong with Vice Mayor Perkins voting on this item. Therefore, he has advised her that it is permissible for her to vote on the item.

A motion was made by Vice Mayor Perkins, seconded by Commissioner McGee, that the Regular Agenda/ Resolution be ADOPTED and to insert the name KATHERYN GILLIS. Mayor Hardin nominated Katheryn Gillis. The motion carried unanimously.

Enactment No: RES. No. 2022-143

19. [22-366](#) A RESOLUTION OF THE CITY COMMISSION OF THE CITY OF POMPANO BEACH, FLORIDA, APPOINTING NANCY GRANT TO THE AIR PARK ADVISORY BOARD OF THE CITY OF POMPANO BEACH FOR A TERM OF THREE (3) YEARS; SAID TERM TO EXPIRE ON MAY 27, 2025; PROVIDING AN EFFECTIVE DATE.

(Fiscal Impact: N/A)

PLEASE REFER TO FILE ID NO 22-365 FOR APPLICANTS.

(Staff Contact: Asceleta Hammond)

A motion was made by Vice Mayor Perkins, seconded by Commissioner McGee, that the Regular Agenda/ Resolution be ADOPTED and to insert the name NANCY GRANT. Vice Mayor Perkins nominated Nancy Grant. The motion carried unanimously.

Enactment No: RES. No. 2022-144

20. [22-367](#) A RESOLUTION OF THE CITY COMMISSION OF THE CITY OF POMPANO BEACH, FLORIDA, APPOINTING FRANK SELLERS TO THE AIR PARK ADVISORY BOARD OF THE CITY OF POMPANO BEACH AS ALTERNATE #2, FOR A TERM OF THREE (3) YEARS; SAID TERM TO EXPIRE ON JULY 1, 2025; PROVIDING AN EFFECTIVE DATE.

(Fiscal Impact: N/A)

PLEASE REFER TO FILE ID NO 22-365 FOR APPLICANTS.

(Staff Contact: Asceleta Hammond)

A motion was made by Vice Mayor Perkins, seconded by Commissioner McGee, that the Regular Agenda/ Resolution be ADOPTED and to insert the name FRANK SELLERS. Commissioner McMahan nominated Frank Sellers. The motion carried unanimously.

Enactment No: RES. No. 2022-145

21. [22-360](#) A RESOLUTION OF THE CITY COMMISSION OF THE CITY OF POMPANO BEACH, FLORIDA, APPOINTING TOBI AYCOCK TO THE ARCHITECTURAL APPEARANCE COMMITTEE OF THE CITY OF POMPANO BEACH FOR A TERM OF THREE (3) YEARS; SAID TERM TO EXPIRE ON MAY 16, 2025; PROVIDING AN EFFECTIVE DATE.

(Fiscal Impact: N/A)

APPLICANTS:

Tobi Aycock, Registered Building Contractor/**Incumbent** - District 3

John A. Pancoast, Landscape Architect/**Incumbent** - District 1

Brian Campbell, Architect General Contractor, Alternate #2/**Incumbent** - District 4

(Staff Contact: Asceleta Hammond)

A motion was made by Vice Mayor Perkins, seconded by Commissioner McGee, that the Regular Agenda/ Resolution be ADOPTED and to insert the name TOBI AYCOCK. Commissioner McMahan nominated Tobi Aycock. The motion carried unanimously.

Enactment No: RES. No. 2022-146

22. [22-361](#) A RESOLUTION OF THE CITY COMMISSION OF THE CITY OF POMPANO BEACH, FLORIDA, APPOINTING JOHN PANCOAST TO THE ARCHITECTURAL APPEARANCE COMMITTEE OF THE CITY OF POMPANO BEACH FOR A TERM OF THREE (3) YEARS; SAID TERM TO EXPIRE ON MAY 16, 2025; PROVIDING AN EFFECTIVE DATE.

(Fiscal Impact: N/A)

PLEASE REFER TO FILE ID NO 22-360 FOR APPLICANTS.

(Staff Contact: Asceleta Hammond)

A motion was made by Vice Mayor Perkins, seconded by Commissioner McGee, that the Regular Agenda/ Resolution be ADOPTED and to insert the name JOHN PANCOAST. Commissioner McGee nominated John Pancoast. The motion carried unanimously.

Enactment No: RES. No. 2022-147

23. [22-362](#) A RESOLUTION OF THE CITY COMMISSION OF THE CITY OF POMPANO BEACH, FLORIDA, APPOINTING BRIAN CAMPBELL TO THE ARCHITECTURAL APPEARANCE COMMITTEE OF THE CITY OF POMPANO BEACH AS ALTERNATE #1, FOR A TERM OF THREE (3) YEARS; SAID TERM TO EXPIRE ON MAY 16, 2025; PROVIDING AN EFFECTIVE DATE.

(Fiscal Impact: N/A)

PLEASE REFER TO FILE ID NO 22-360 FOR APPLICANTS.

(Staff Contact: Asceleta Hammond)

A motion was made by Vice Mayor Perkins, seconded by Commissioner McGee, that the Regular Agenda/ Resolution be ADOPTED and to insert the name BRIAN CAMPBELL. Commissioner Floyd nominated Brian Campbell. The motion carried unanimously.

Enactment No: RES. No. 2022-148**G. NEXT SCHEDULED MEETING**

May 24, 2022 at 6:00 p.m. - Regular City Commission Meeting

H. REPORTS

Gregory Harrison, City Manager - Florida Homeowner Assistance Fund Information - Mr. Harrison stated while the meeting was in recess he provided a copy of information along with Pompano magazine on the

dais for the Commission. The information from the Florida Homeowner Assistance Fund is a new fund through the State of Florida and it is not as restrictive as the Federal funds that were coming to the City. This is information being provided for the community that may want to be heard again through the process. The City will be happy to assist those individuals through the process, but we would not have the determining factor on disbursement of those monies.

Continuing, Mr. Harrison indicated that the magazine he provided to the Commission is the Pompano Magazine dedicated to the Fisher Family Pier. He felt they should each have a copy since they got soaked on the night of the dedication.

Mayor Hardin mentioned that perhaps the magazine could be a collector's item as this does not happen often in people's lifetime. He thanked the City Manager for this.

Mark Berman, City Attorney - No Report.

Asceleta Hammond, City Clerk - No Report.

Commissioner Rhonda Eaton - Cresthaven Civic Association Monthly Meeting - Comr. Eaton announced that the Cresthaven Civic Association will be meeting on Thursday, May 12, 2022 at 7:00 p.m. at the Charlotte Burrie Center. This meeting takes place monthly on the second Thursday of every month.

Demise of Richard White - Comr. Eaton expressed her condolences out to the family of Richard White, who was a long-time board member of the Cresthaven Civic Association. She recognized him for his commitment to public service, and he will be missed.

Street Lighting - Comr. Eaton reported that the surveying is beginning and stakes are being put in the ground in some areas of District 2 for the street lighting. She is happy to see this and she has received a number of questions. She has put the information out on social media. There is some wiggle room and if anyone has an issue they can contact her through her City email or mobile phone. These lightings will make the streets safer and she is convinced that opportunity for crime will not be there. This is a wonderful thing for the City.

Commissioner Cyndy Floyd - 911 Communications Issue - Comr. Floyd enquired if there were any changes with the 911 Communications situation. She requested to be informed and kept up to date regarding this matter.

Greg Harrison, City Manager, reported that Fire Chief Chad Brocato has been the City's representative on this project. He invited Mr. Brocato to provide an update to the Commission.

Chad Brocato, Fire Chief, provided a brief background on the 911 matter in general. He sits on the Operational Review Team Board that provides oversight to ORCAT (Office of Regional Communications and Technology), which is the hardware and software side of dispatch. There are 2 pieces, 1 is the County by itself doing the hardware and software, and the other piece is the Broward Sheriff's Office (BSO), which provides personnel that actually do the dispatching. He also sits as Vice President of the Fire Chief Association of Broward County. The reason for providing this information is to note that the City has been involved in this

effort for quite some time. This is a problem seen nationwide. This past week they met with the City of Coral Springs, which equipped them with options that they would be able to bring back to the City Commission. Option 1 is the simplest, and involves the City remaining where we are, and to continue to allow BSO to do the dispatching, and stay in the ORCAT backbone in hardware and software. Option 2 would be if the City went off on its own. This year this will be looked at through the budgetary process. There are no fast options, as the City no longer has a facility. They are looking to design the Emergency Operations Center (EOC), but it is still a couple of years out. It would take 18-24 months before that structure is built.

Continuing, Chief Brocato mentioned the first concern is where to put the Call Center, which cannot be put in any building. Space is not enough, there needs to be other things to get that Call Center established. A number of options are being explored, and one such is to partner with City of Coral Springs, which is what the City of Coconut Creek did recently. Another option is Coconut Creek has some space in their facility for a PSAP (Public Safety Answering Point) call center. These are the options that will be considered first because these are most ground level - least costly.

Chief Brocato stated that he has also been working with Motorola to determine the communication hardware software in the event the City wants to do this on its own. This would be approximately \$2-5 million to get started. Next, there will be ongoing costs for dispatchers, which will be approximately 10-15. Coral Springs offered to assist with training and getting people hired and get them up and running. He pointed out that Coral Springs and Plantation does their own dispatching. All other cities throughout Broward County utilize the BSO.

In sum, this would be a 3 tier. Tier 1 is to remain where we are, tier 2 is to try and find a facility within the City that can be utilized or leased out as mentioned in the case of Coconut Creek, and tier 3 is to have the City to be completely on its own, which is not a fast option. Most likely either tier 1 or tier 2 is feasible at this time. He explained that tier 1 would still involve the City partnering with the BSO. Overall, everyone is experiencing staffing shortages.

Continuing, Chief Brocato mentioned that Sheriff Tony would be presenting to the Broward County Commission and he saw an article that mentioned the Sheriff would be asking for \$11 million in salaries to bring up the pay for the dispatchers, and \$17 million for a facility. In addition, he reported the Fire Chiefs met this past Thursday to address the current issues, and ways they can resolve some of the challenges by assisting the BSO.

Finally, Chief Brocato indicated that this is a multi-level matter and he is exploring the various options mentioned earlier. He will return to update the Commission when he has a number of options for their consideration.

Comr. Floyd stated that Chief Brocato did answer her question, however, she felt option 1 is leaving the City too vulnerable and is unacceptable. Perhaps Option 2 would be worth exploring.

Mayor Hardin thanked Chief Brocato for the update.

Comr. McMahon asked if the City Commission could be provided with a monthly report on call times and things like that.

Chief Brocato mentioned that there is a monthly report that is generated by ORCAT, the backbone system, which he will be able to get that report out to the Commission, and he would be happy to meet with each Commissioner to explain the hard data from this report.

Homeownership 101 Event - Comr. Floyd stated that she along with the Kappa and Marty Kiar will be presenting Homeownership 101 event, which will be held on May 19, 2022, from 6:00 - 8:00 p.m., at the McNair Park Gymnasium. This will be a free 2-hour informative event that will provide the steps on how to become a homeowner, and provide answers to questions about the home buying process. Topics that will be discussed is Renting versus Owning, and the steps to take to apply for a mortgage, the importance of housing counselling, and how to determine your area mean income. Also, how to obtain the best government loan assistance program with down payment and closing costs in the City of Pompano Beach. She extended an invitation to everyone to come out and support this worthy cause.

Commissioner Andrea McGee - Staff's Resolution to Condominium Issue - Comr. McGee thanked staff for taking care of the issue with one of the condominiums on the beach. Due to staff's fast acting abilities everything was resolved with their insurance issue that they were experiencing. They were extremely grateful for staff's intervention.

Completion of Beach Renourishment - Comr. McGee reported that the Beach Renourishment has completed with total sand replacement of Segment II being 397,087 cubic yards from south of Pompano in Fort Lauderdale to Hillsboro Inlet. The aerial will show the reclaimed areas of beach and recovered boulders that would keep houses from going into the water. This was a great and necessary project. Thanks to everyone involved to include the Army Corps., the State Representatives, County Officials to include our own Broward County Vice Mayor Lamar Fisher, and to all the residents for putting up with constant truckload of sand coming in and out of access roads.

Continuing, Comr. McGee mentioned that this was such a successful project it has led to the City being featured nationwide on Fox and Friends TV. A still shot of the Fisher Family Pier and referred to Pompano Beach as gorgeous, which it is.

Greg Harrison, City Manager mentioned that there will be a military looking ATV starting to roll down that area of the beach. These are inspectors on the beach renourishment project. Perhaps Comr. McGee may want to provide this information to her constituents through the way she connects with them. He will be able to provide her a photograph of this military looking ATV.

Commissioner Tom McMahon - 911 Call Center - Comr. McMahon mentioned that he had a question on the 911 issue but got his answer.

Demise of Don Downy - Comr. McMahon expressed condolences to the Don Downy family. There is a big map in City Hall lobby and the E Pat Larkins Center that was hand drawn as to where things were 75 years ago and who lived where, their names and addresses. Mr. Downy was passionate about saving the history of Pompano Beach. He got the City to listen and was able to put up the maps. He asked that the City keep his family in their prayers. He has done a lot of great service for the City, and served on so many boards in the

City. Consequently, he has asked Mayor Hardin to do a proclamation at his funeral service. He will provide the details to Executive Secretary, Shelley Bartholomew for the proclamation.

Vice Mayor Beverly Perkins - Continuing Issues with Bulk Trash - Vice Mayor Perkins reported she had a meeting last week with the City Manager and Russ Ketchem, Solid Waste Director. However, she is still having the same problems with the trash in the northwest community. She sent a picture to Mr. Ketchem of NW 4th Avenue in Sanders Park. Trash was put there on Friday and as of this morning it remains in place. She is still not seeing trash being cleared on NW 6th Avenue. This is a gateway to the High School and she would like to see the job done well, even if it means to cite those owners on private properties. She has been going to the churches to get the residents informed on keeping the community clean, however, she will need Mr. Ketchem to do his part in this effort.

Kodak Black Concert - Vice Mayor Perkins mentioned there is a rumor going around that Kodak Black is having a concert in Pompano Beach. She would like to be informed about this if this is so.

Greg Harrison, City Manager stated that Mr. Black's concert assistants have filled out an event application that has gone through the City's event application process with Fire, Police, Public Works, Solid Waste, as well as Parks and Recreation. The application is in the mail.

Vice Mayor Perkins asked for the date when this concert will happen and the location.

Mr. Harrison responded that it maybe sometime in June, he does not have the exact date at this time. However, he could provide this to Vice Mayor Perkins. Also, the concert will take place in the Community Park, if they come through with everything they say they will do on their event application. In other words, it is not a done deal yet, but is in the process currently.

Beautification of Roundabouts - Vice Mayor Perkins reported that she has always been complaining about the roundabouts on NW 6th Avenue, however, there are beautiful plants all around the roundabouts and she did not have to call to complain. So, she expressed her thanks to Public Works Director Robert McCaughan for getting this done, and indicated that it looks very nice.

Mayor Rex Hardin - Kodak Black Concert - Mayor Hardin in following-up on the concert of Kodak Black, asked if that will be held at the Amphitheater.

Mr. Harrison responded no. The diagram that he saw was setting up a stage on the east end of the Community Park which it would be facing west. He confirmed that it will be an individual concert. He can provide the Commission with a copy of the draft event application, if so desired. Normally, he does not provide an event application to the City Commission, unless it is requested. Moreover, it has not fully been determined yet if the organizers of this concert will pay the 7 days in advance cost for the public safety of the event to Broward Sheriff's Office (BSO).

Vice Mayor Perkins stated the only reason she asked about this is because this appears to be a very high-profile concert, as well as the individual was born and raised in her district. It appears everyone was asking her about this matter, and she had heard nothing about it until now. She thanked the City Manager for

the information on this.

Comr. Floyd mentioned that they are having a Community Safety Day the same date of June 11, 2022; therefore, if they could avoid not having the concert going on at the same time.

Comr. Eaton asked if she could get clarification on the Mothers' Day Event held at the E. Pat Larkins Center on Mothers' Day. She wanted to know if it was a sponsored event by the City of Pompano Beach.

Mr. Harrison responded that the Parks and Recreation department had a luncheon at the E. Pat Larkins Center on Mothers' Day. This event has been held for many years.

Comr. Eaton mentioned that she did not get an invite to this event and it should not be her responsibility to "leaf" through the web pages on the City site to figure out the events happening and which ones to attend. She mentioned that she has a problem with City sponsored events happening and not everyone throughout the City being invited.

Mr. Harrison stated he is unaware of special invitations going out to any of these events that the Park and Recreation Department sponsors.

Comr. McGee suggested if someone could do calendar invites for the larger Cultural or Parks and Recreation events so the Commission can see them.

Comr. Eaton stated that for special events such as these she would want to get an email from someone telling her about the special event that the City is sponsoring.

Gun Buyback Event - Mayor Hardin announced that there will be a gun buyback day for the City of Pompano Beach. This came about because of the march that took place in northwest Pompano, for Jasmine Brayboy. Pastors Jones, Griffith and Mohorn had organized this event. Vice Mayor Perkins and Comr. Floyd were in attendance. The idea for gun buyback was birthed at that march to talk about community violence. Therefore, on June 4, 2022 from 10:00 a.m. to 2:00 p.m. at the E. Pat Larkins Center, the City of Pompano Beach will be hosting a gun buyback event. The Broward Sheriff's Office will be involved with this effort and they will have flyers available. He thanked the pastors for making the march happen and the initial idea for this event.

Memorial Day Celebration - Mayor Hardin announced there will be a Memorial Day celebration on May 30, 2022, at the Pompano Beach Cemetery on Federal Highway. Parks and Recreation is making plans for this event.

I. ADJOURNMENT

The meeting was adjourned at 3:53 p.m.

Rex Hardin, Mayor

Asceleta Hammond, City Clerk

S.E 6th Terrace Bridge Pompano Beach



Existing Bridge Background:

- Bridge is located at the intersection of SE 11th Ave. and SE 6th Terrace
- Original bridge was built 1960 and is 62 years old and functionally obsolete
- Bridge is currently 36' wide with one lane in each direction
- Current vertical clearance under the bridge is approximately +/-8.6' to the Mean High Water Table (MHWT)
- Current posted speed is 15 MPH
- Sidewalk is located on one side only (west side)

S.E 6th Terrace Bridge Pompano Beach



New Bridge Limitations:

- Fixed ends of the bridge are skewed
- Length of the bridge is 100'
- Private residences on south side
- Maximum grade of 8%
- Vertical navigation clearance limited to max. grade slope

S.E 6th Terrace Bridge Pompano Beach

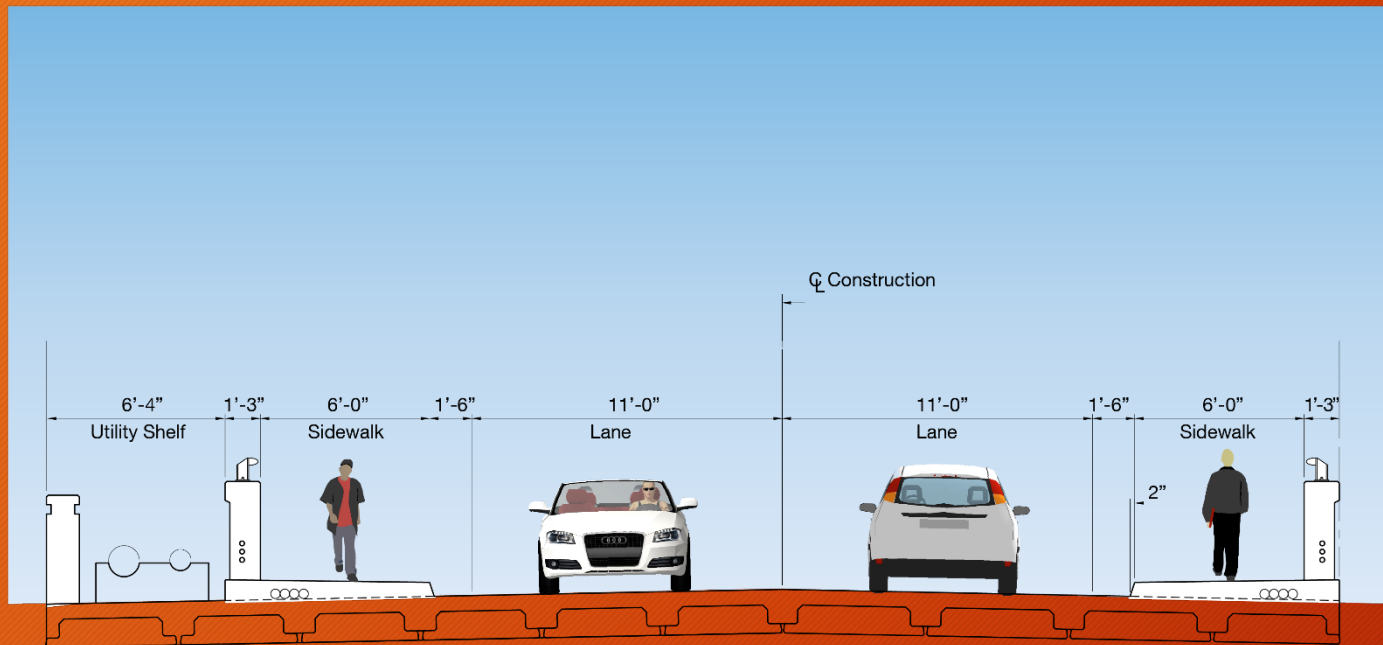

New Bridge Improvements:

- Vertical clearance will be increased to improve boating traffic
- Vehicular sight lines will be increased to meet criteria and increase safety
- Sidewalks will be provided on each side to increase pedestrian safety

S.E 6th Terrace Bridge Pompano Beach



Current Bridge Design:

- Proposed design provides an approximate maximum vertical clearance of 10.11' MHWT or +/-17" higher than the existing bridge

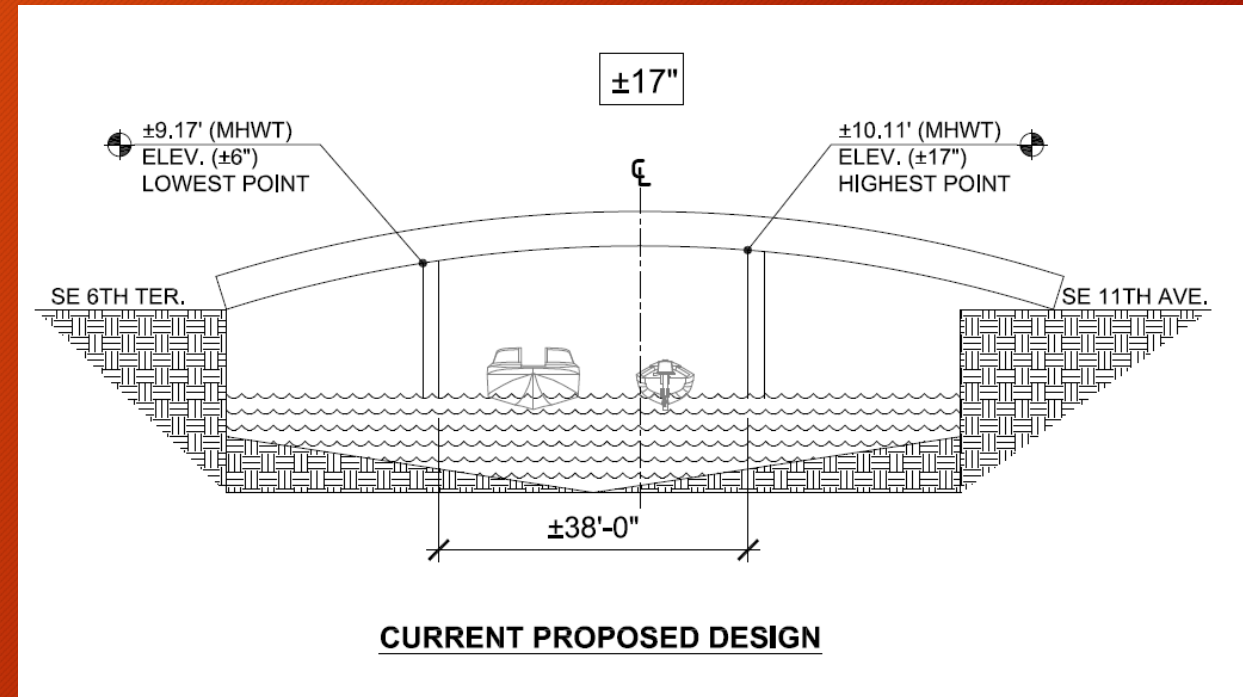
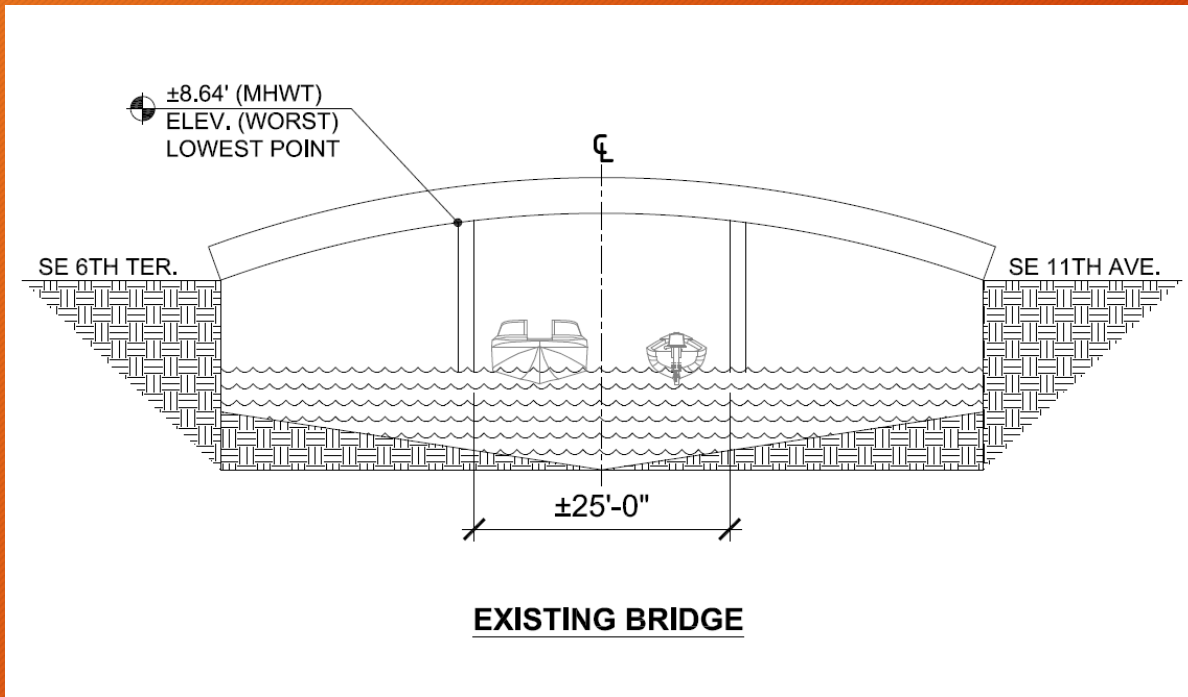

S.E 6th Terrace Bridge Pompano Beach

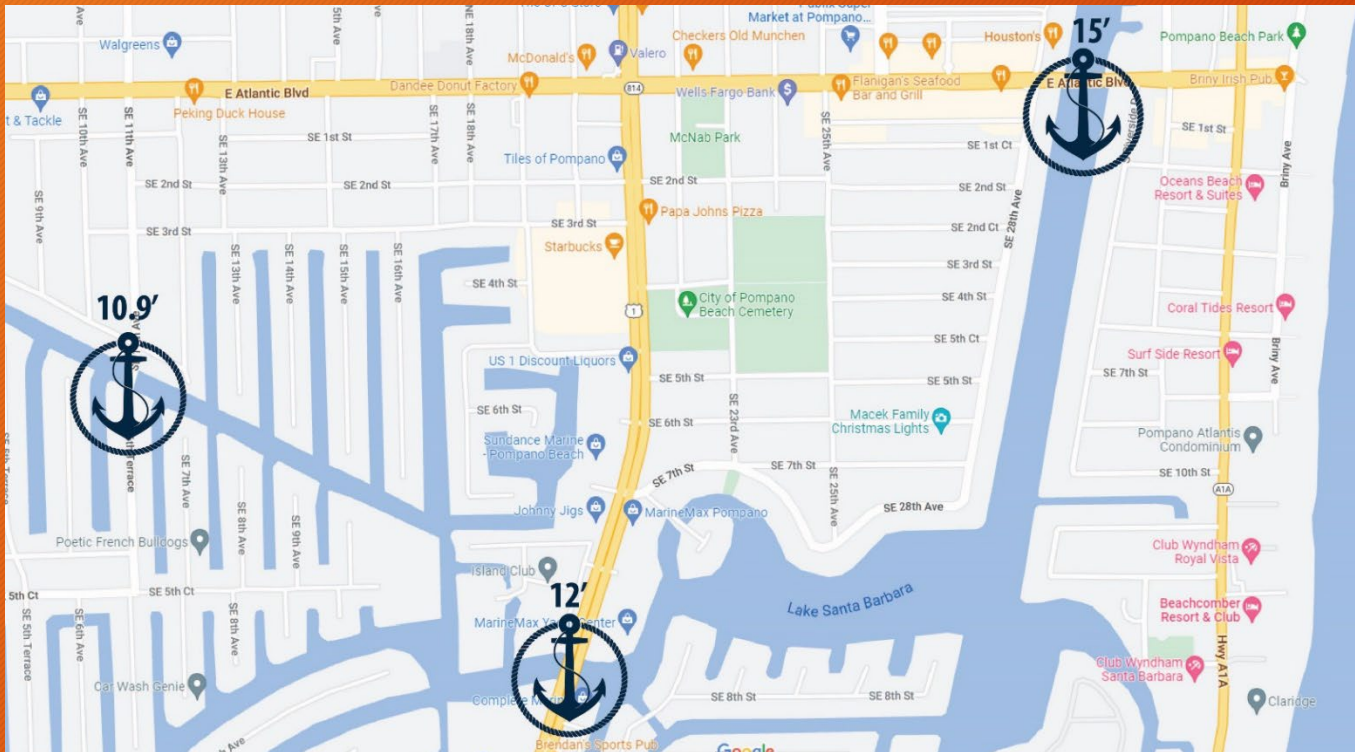

Exploring Alternate Bridge Design:

- Contributing factors:
 - Cost
 - Feasibility
 - Vertical Clearance

S.E 6th Terrace Bridge Pompano Beach



Exploring Alternate Bridge Design:

- Alternate #1 - Tunnel Design
 - Cost: \$20M-35M
 - Feasibility: Not practical
 - Vertical Clearance: Unlimited

S.E 6th Terrace Bridge Pompano Beach



Exploring Alternate Bridge Design:

- Alternate #2 - Swing Bridge
 - Cost: \$10M-15M
(not including maint. Cost)
 - Feasibility: Not practical
 - Vertical Clearance: Unlimited

S.E 6th Terrace Bridge Pompano Beach



Exploring Alternate Bridge Design:

- Alternate #3 - Bascule
 - Cost: \$10M-15M
(not including maint. Cost)
 - Feasibility: Not practical
 - Vertical Clearance: Unlimited

S.E 6th Terrace Bridge Pompano Beach



Exploring Alternate Bridge Design:

- Alternate #4 - Extend Bridge
 - Cost: \$5.1M
 - Feasibility: More practical
 - Vertical Clearance: Best Option

S.E 6th Terrace Bridge Pompano Beach

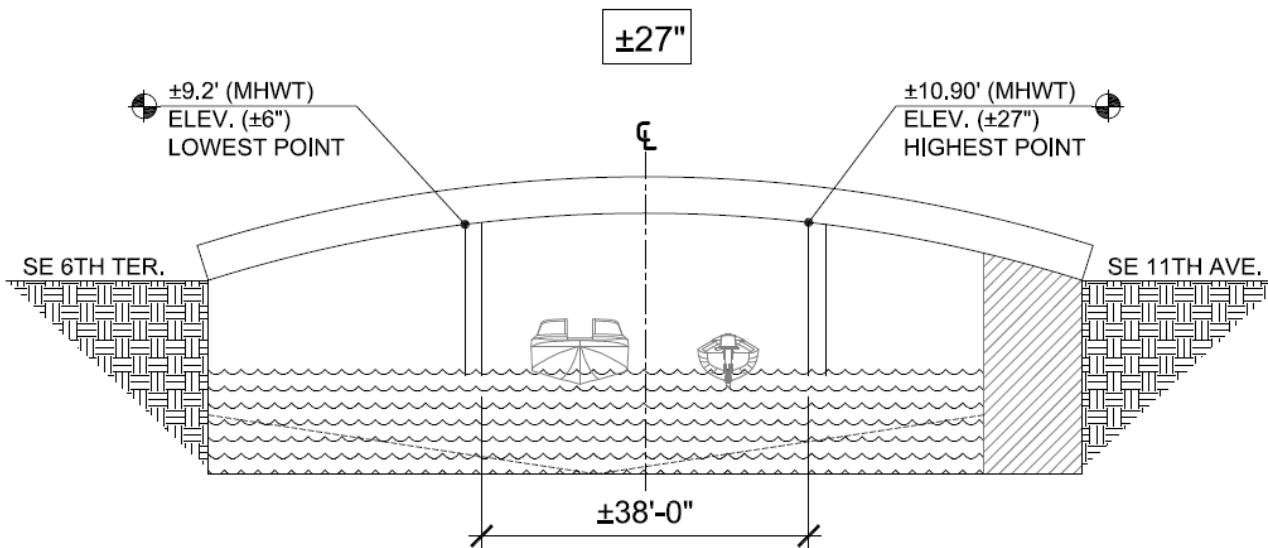

PROPOSED ALT. #4 DESIGN

Exploring Alternate Bridge Design:

- **Advantages:**
 - Navigation traffic is improved for vessels traveling in both directions
 - Increase maximum vertical clearance to approx. 10.9' MHWT or 27" greater than the current bridge
- **Disadvantages:**
 - Project overall cost increase
 - Increased construction timeline

S.E 6th Terrace Bridge Pompano Beach



New Bridge Estimated costs:

- Current design will cost approximately \$3.7M

Budget Considerations:

- | | |
|-------------------------------|---------|
| • Current project budget: | 1.5M |
| • Current project costs: | 3.7M |
| • Alternate #1 Tunnel cost: | 20M-35M |
| • Alternate #2 Swing cost: | 10M-15M |
| • Alternate #3 Bascule cost: | 10M-15M |
| • Alternate #4 Extend Bridge: | 5.1M |

S.E 6th Terrace Bridge Pompano Beach



Conclusion:

- New bridge will:
 - Meet new bridge standards
 - Increase vehicular safety by providing better visibility
 - Increase pedestrian safety by providing sidewalks on both sides to avoid crossing at the bridge
 - Increase vertical clearance

Staff Recommendation:

- Staff recommends moving forward with Alternate #4, which provides the best vertical clearance of +/-27" from the existing bridge given the existing constraints (5.1M),