

**PROPERTY DETAILS**  
 Address: 3685 N FEDERAL HWY, POMPANO BEACH FL 33064  
 Owner(s): KAIA PROPERTIES INC  
 Folio: NORTH POMPANO BEACH SEC A 29-15 B LOTS 7,8,9, BLK 1  
 Parcel ID: 4843 18 01 0100

**PLANNING & COMMUNITY DEVELOPMENT**  
 Zoning Designation: B-3  
 Zoning Description: B-3 GENERAL COMMERCIAL  
 Designating Agency: POMPANO BEACH  
 Future Land-Use Designation: COMMERCIAL  
 LOT Size (Current): 37497 SF 0.861 Acres  
 Less ROW Dedication - Federal: -139 SF 11" -0.003 Acres  
 Less ROW Dedication 18th Terrace: -758 SF 5'-0" -0.017 Acres  
 LOT Size (Proposed): 36600 SF 0.840 Acres  
 Proposed Use: Sec 155-4219 (H) Automatic dragline car wash with self service vacuums

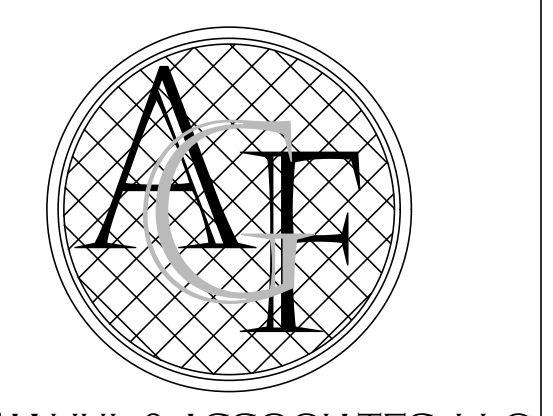

**FANJUL & ASSOCIATES, LLC**  
 ARCHITECTURE, PLANNING & INTERIOR DESIGN  
 AA26000725  
**ARTURO G. FANJUL, RA**  
 PRESIDENT  
 5455 SW 8TH STREET, SUITE 240  
 CORAL GABLES, FLORIDA 33134  
 PH. 305 726.8313  
 FAX 305 356.3686  
 arturo@fanjularchitects.com  
 "A BETTER LIFE THROUGH DESIGN"

**B-3 DIMENSIONAL REQUIREMENTS**

REQUIREMENT	REQUIRED	EXISTING	PROPOSED
MAX BUILDING HEIGHT	105'		35'
MIN LOT SIZE	10,000	37497	36600 SF
MIN LOT WIDTH	100'	150'	151'-6"
MAX LOT COVERAGE	60%		4902 13%
MIN PERVIOUS AREA	20%		8627 24%
BUILDING SETBACKS			
MINIMUM FRONT SETBACK (FT)	0'	N. Federal	1'-11" (E)
MINIMUM SIDE YARD (FT)	0'		(N)115' (S)5'
MINIMUM FRONT SETBACK (FT)	0'	18th Terrace	1'-1" (W)

**PARKING DIMENSIONS TABLE**

STANDARD	CODE SECTION	REQUIRED	PROPOSED
PARKING DIMENSIONS		9'-0" X 18'	12'X18'
MIN. DRIVE AISLE WITH 90 DEGREE		24'	26'
2 WAY DRIVE AISLE WIDTH		24'	MIN 24'
1 WAY DRIVE AISLE WIDTH		12'	MIN 12'

**VEHICULAR PARKING REQUIREMENT**

REQUIRED SPACES	AREA (SF)	RATIO	TOTAL REQUIRED
USE			
CARWASH, FULL SERVE AUTOMATIC	4790	1/500 SF	10
PROVIDED SPACES			
PARKING SPACES	9	ADA	10
VACUUM STATIONS			11

**AUTO WASH STACKING REQUIREMENTS**

USE	REQ. INBOUND	REQUIRED	PROVIDED
TICKET GATE (AUTO PAY KIOSK)	2 SPACES/EA	6	30 Car Capacity

**GENERAL ZONING USE:**  
 155-4219 (H) Car Wash or Auto Detailing

- Definition  
 A car wash or auto detailing use is an establishment providing the washing of the exterior of vehicles where vehicles are manually driven or pulled by a conveyor through a system of rollers and/or brushes. Interior cleaning and/or drying may be conducted manually by vehicle operator or on-site attendants. Interior cleaning and/or drying may be conducted manually by the vehicle operator or on-site attendants.
- Standards  
 A car wash or auto detailing use shall comply with the following standards:  
 a. The use shall be designed to ensure proper functioning of the site as related to vehicle stacking, circulation, and turning movements.  
 b. No overhead doors shall face the front lot line.  
 c. Each lane shall be covered with a permanent canopy which shall have a maximum clearance height of 14 feet above grade, except where state or federal law requires a higher clearance.

**MISCELLANEOUS SITE EQUIPMENT**

ITEM	QTY
MAT BRUSHER & PAD - J-KO MODEL BB-X	4
MAT SINK	1
FLAG POLE - MODEL ECH-35	1
VACUUM ARCHES WITH AIR	23
OTT STANDS	2
XPT POINTS OF SALE	2
WAIT / GO SIGN & POST	1

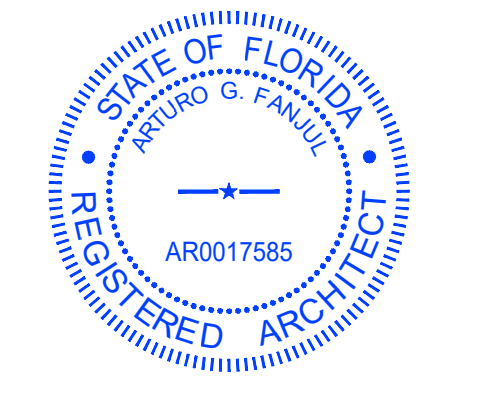

This item has been electronically signed and sealed by:  
 Printed copies of electronically signed, dated, and sealed documents are not considered signed and sealed and the data authentication code must be verified on any electronic copies.



3685 N. FEDERAL HWY  
 POMPANO BEACH, FL

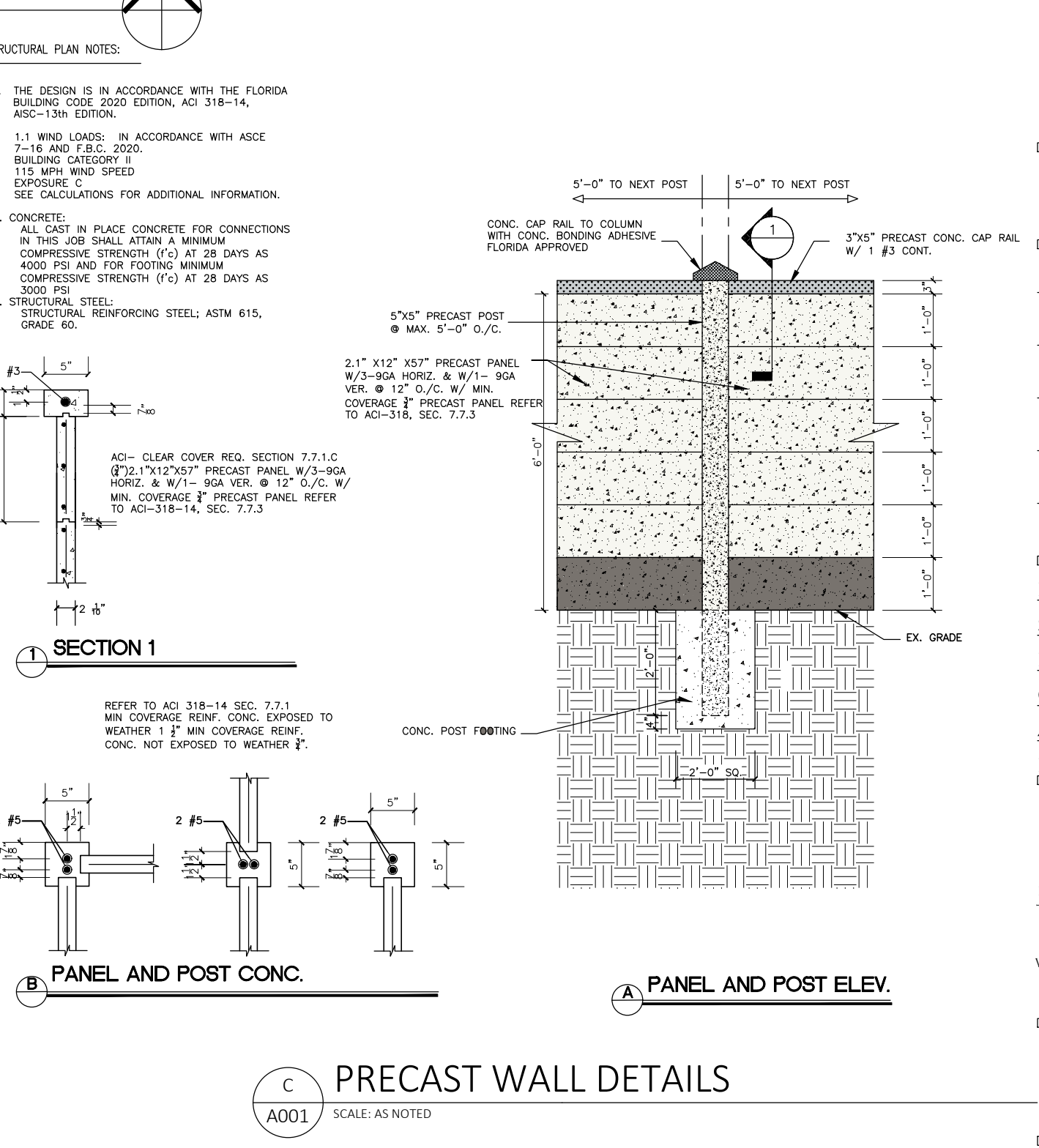
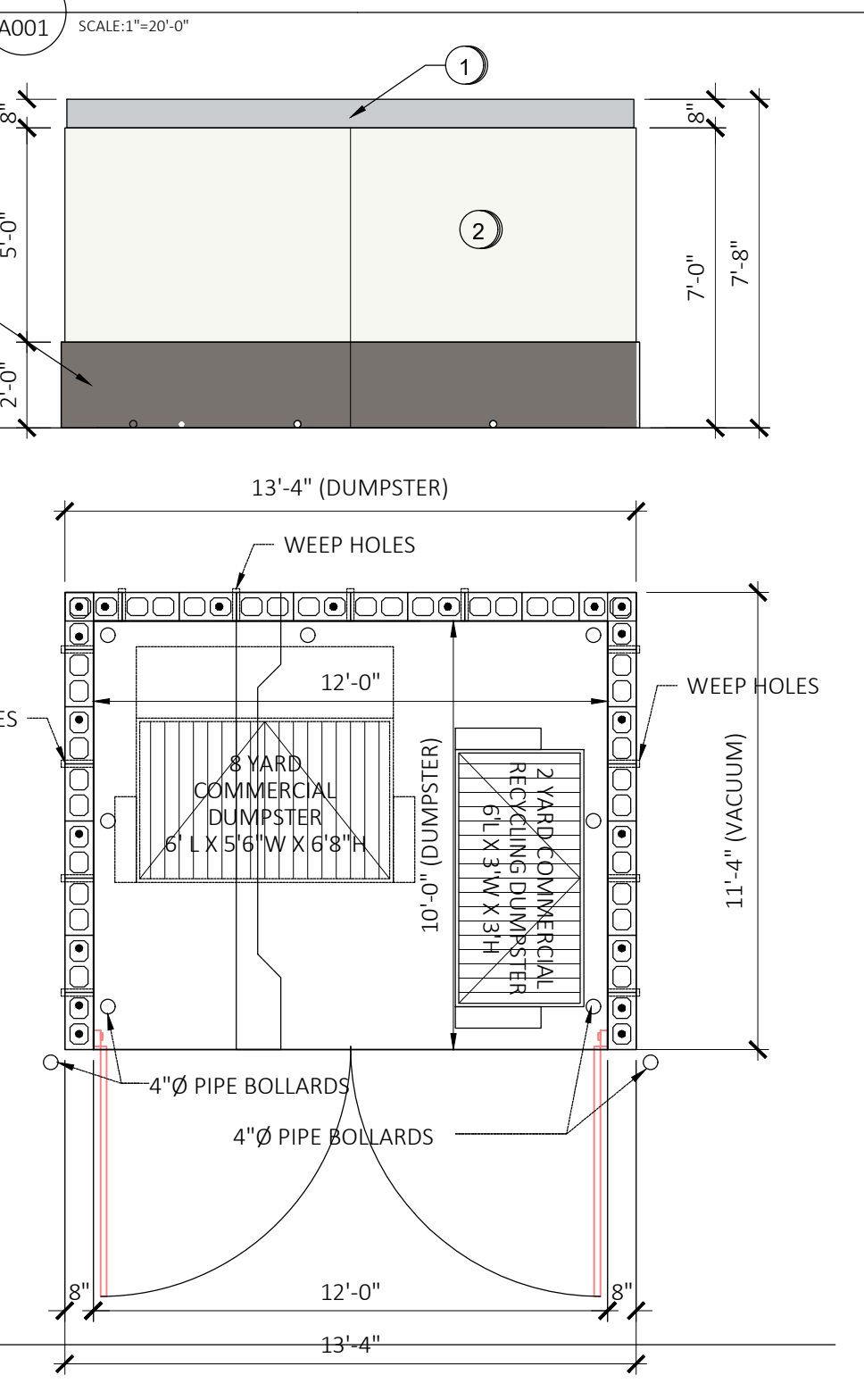
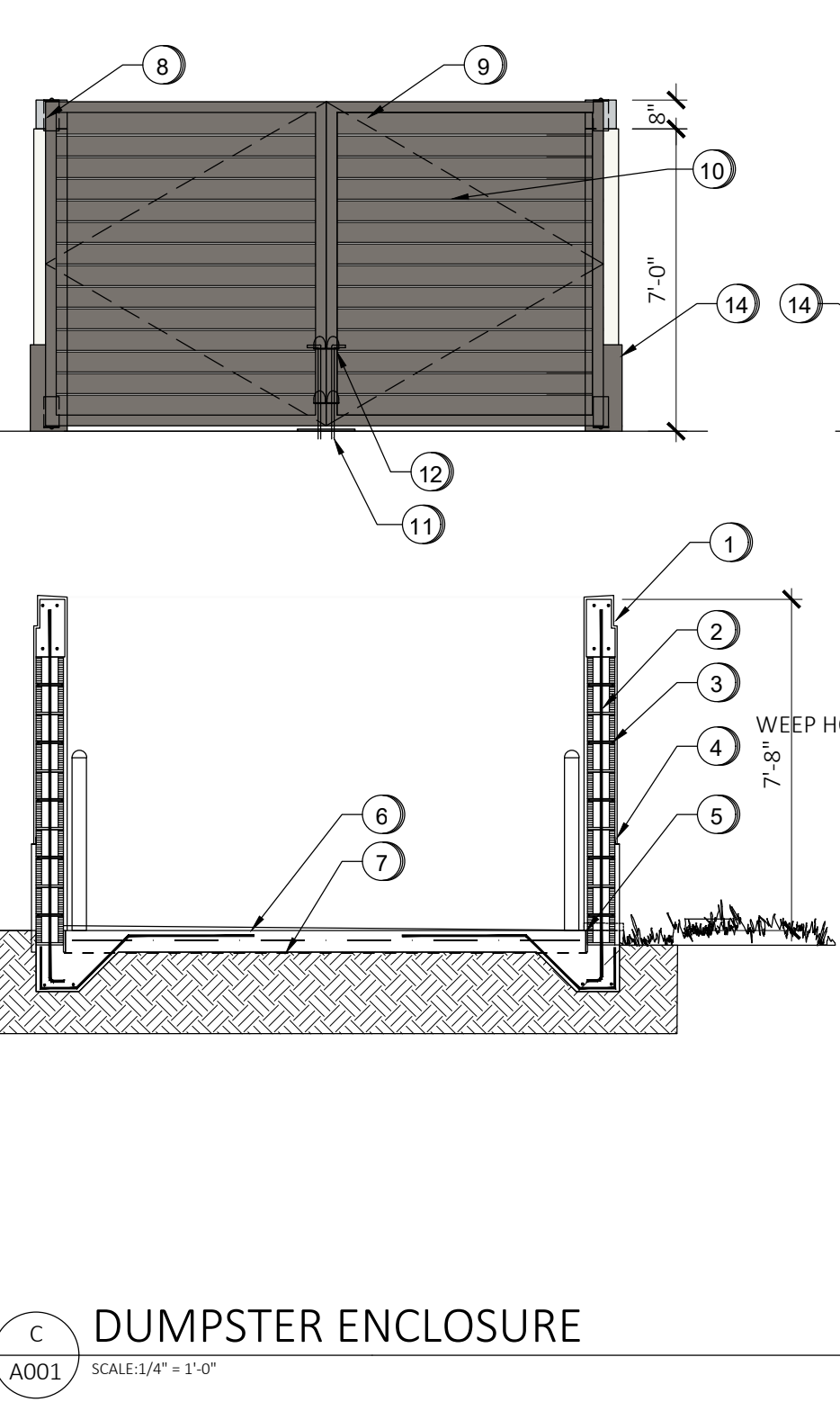
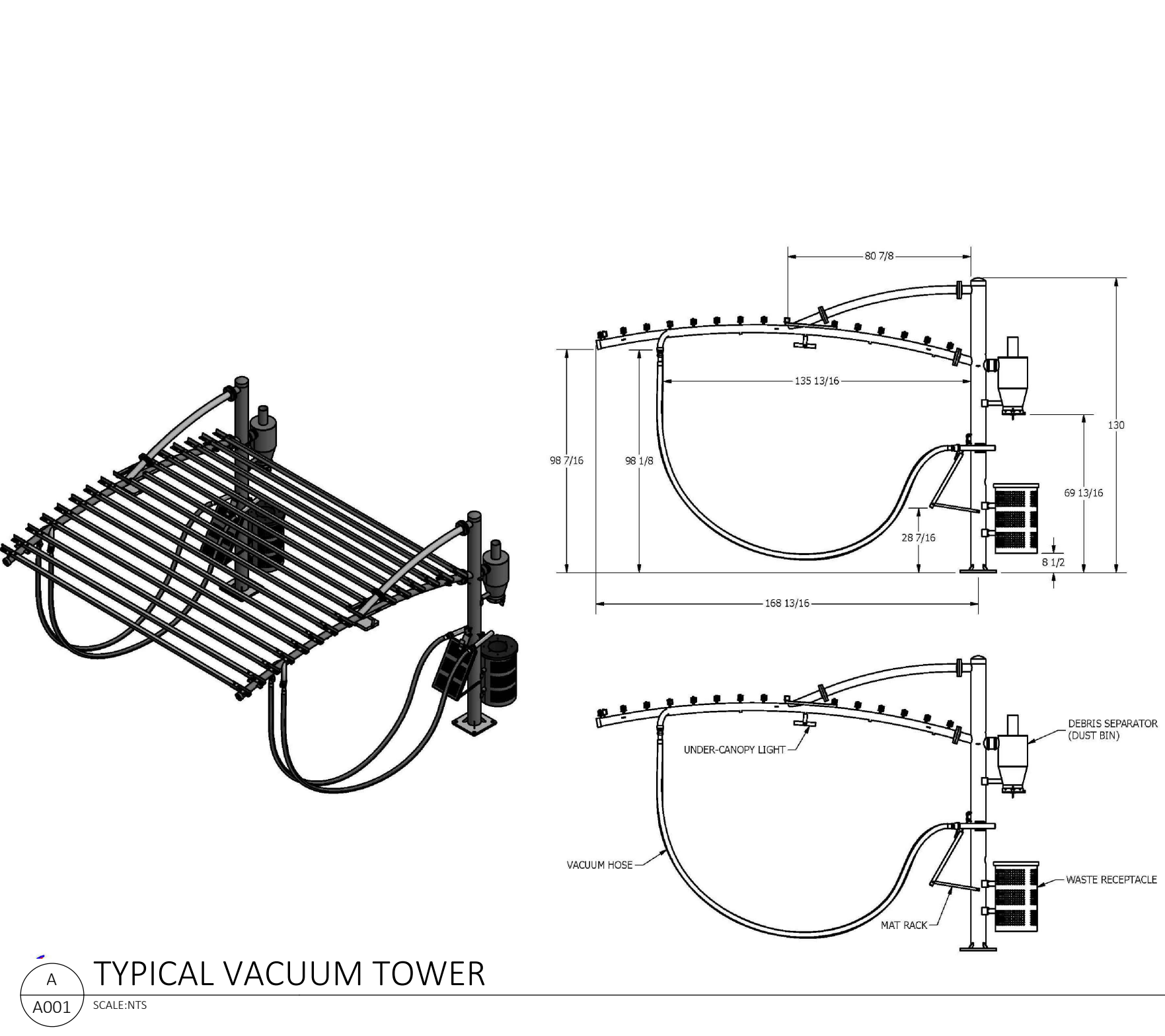

**REVISION NO.**

REVISION	NO.

**PREAPP-COMMENTS**

DATE: 8/18/2023  
 SCALE: AS NOTED  
 DRAWN: AGF  
 CHECKED: AGF  
 JOB NO.: 230701  
 PERMIT NO.:

**OWNERSHIP**  
 OF THESE DOCUMENTS & SPECIFICATIONS AS INSTRUMENTS OF SERVICE ARE AND SHALL REMAIN THE PROPERTY OF THE ARCHITECT WHETHER THE PROJECT THEY ARE MADE FOR IS EXECUTED OR NOT. THEY SHALL NOT BE USED BY OWNER OR OTHERS ON OTHER PROJECTS OR FOR ADDITIONS TO THIS PROJECT BY OTHERS, EXCEPT BY AGREEMENT IN WRITING AND WITH APPROPRIATE COMPENSATION TO THE ARCHITECT.

**SP-1**