

No tree will be removed or replanted as part of this permit See attached survey supplied by owner for exact property information.

Site Address	2860 NE 9 STREET, POMPANO BEACH FL 33062	ID #	4843 31 21 0530
Property Owner	COOK, LARRY J	Millage	1511
Mailing Address	2860 NE 9 ST POMPANO BEACH FL 33062	Use	01-01
Abbr Legal Description	HARBOR VILLAGE SEC F 43-15 B LOT 10 BLK 17		

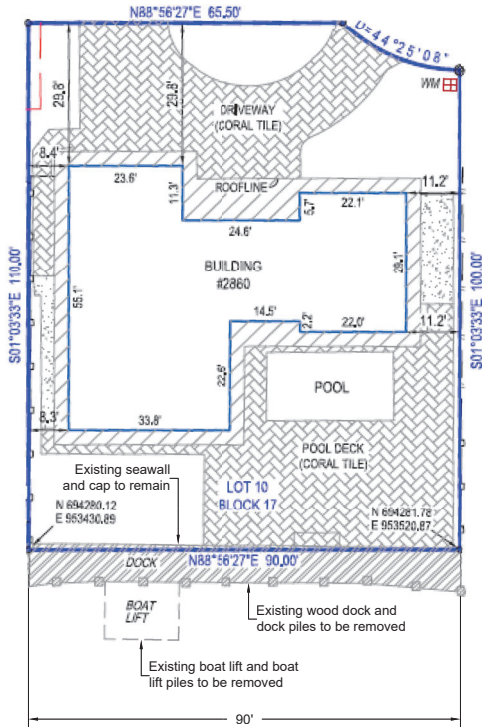

CANAL CAPRI
(100' R/W)

Existing Site Plan

Scale: 1" = 20'

Consultant
UNLIMITED PERMIT SERVICES, INC
Marine Design & Consulting
902 NE 1st Street #2
Pompano Beach, FL 33060
(954) 532-0129
Office@unlimitedps.net

Project Engineer
DYNAMIC ENGINEERING SOLUTIONS, INC
1950 NE 6 Street #10075
Pompano Beach, FL 33061
Office: (954) 860-5263

Contractor
THE DOCK EXPERTS
2670 North Federal Highway
Lighthouse Point, FL 33064
(754) 200-4852
CGC1527192 & SCC131152145

Project Information
Seawall Repair / New Dock
Larry Cook
2860 NE 9 Street
Pompano Beach, FL 33062

DATE
4-8-24
4-24-24

Location Map

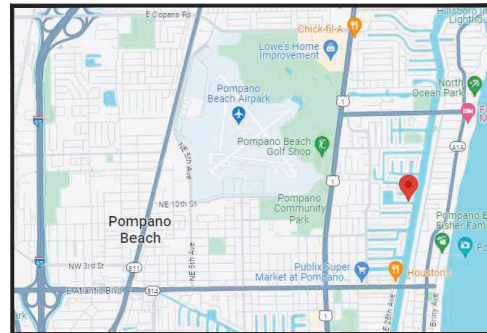

"This document has been electronically signed and sealed by John H. Omslaer, P.E. on date noted using a SHA-1 authentication code. Printed copies are not considered signed and sealed and the SHA-1 authentication code must be verified on any electronic copies per Rule 62-30.080, F.A.C."

Digitally signed by John H. Omslaer
Date: 2024.04.25 10:06:18 -04'00'

JOHN OMSLAER, P.E.
E.B. #28829 | LICENSE #52733
DYNAMIC ENGINEERING SOLUTIONS INC
1950 NE 6th Street #10075
Pompano Beach, Florida 33061
OFFICE: (954) 860-5263

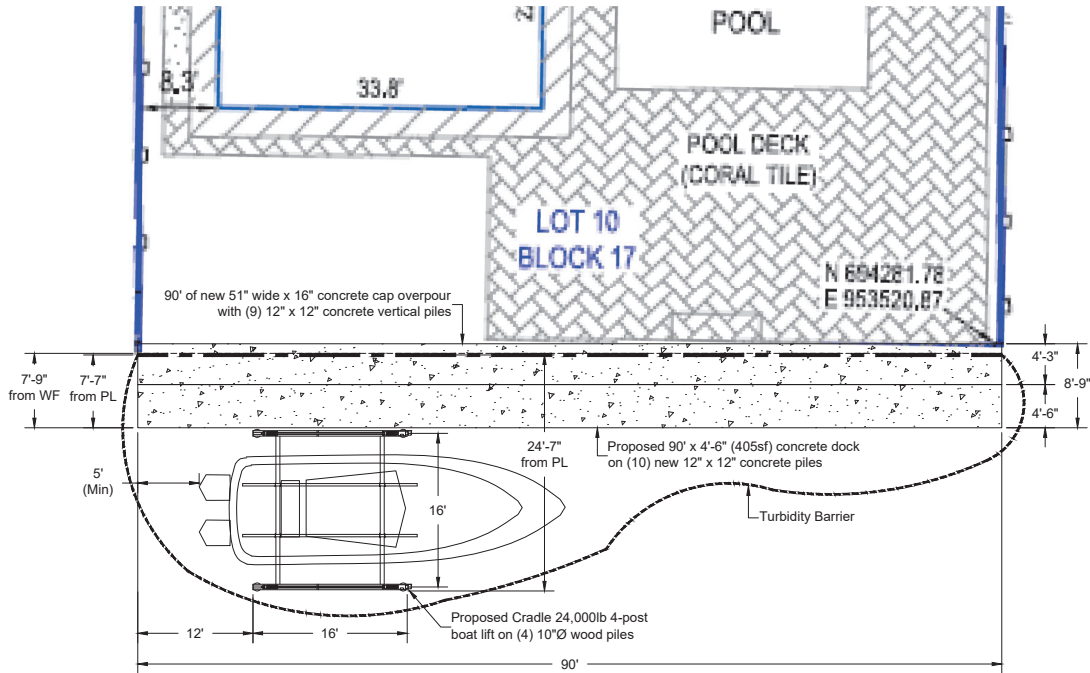

N.E.C. 555.24 Signage. Permanent safety signs shall be installed to give notice of electrical shock hazard risks to persons using or swimming near a boat dock or marina.

CANAL CAPRI
(100' R/W)

- Scope of Work:**
- Existing wood dock and wood piles removed
 - Existing boat lift removed
 - Construct 90' of 51" x 16" concrete cap overpour with (9) vertical piles
 - Install 90' x 4'-6" (405sf) concrete dock on (10) concrete piles
 - Install Cradle 24,000lb 4-post boat lift on (4) wood piles

Proposed Site Plan

Scale: 1" = 10'

Consultant
UNLIMITED PERMIT SERVICES, INC
 Marine Design & Consulting
 902 NE 1st Street #2
 Pompano Beach, FL 33060
 (954) 532-0129
 Office@unlimiteddps.net

Project Engineer
DYNAMIC ENGINEERING SOLUTIONS, INC
 1950 NE 6 Street #10075
 Pompano Beach, FL 33061
 Office: (954) 860-5263

Contractor
THE DOCK EXPERTS
 2670 North Federal Highway
 Lighthouse Point, FL 33064
 (754) 200-4852
 CGC1527192 & SCC131152145

Project Information
Seawall Repair / New Dock
 Larry Cook
 2860 NE 9 Street
 Pompano Beach, FL 33062

DATE
4-8-24
4-24-24

"This document has been electronically signed and sealed by John H. Omslaer, P.E. on date noted using a SHA-1 authentication code. Printed copies are not considered signed and sealed and the SHA-1 authentication code must be verified on any electronic copies per Rule 62-30.060, F.A.C."

Digitally signed by John H Omslaer
 Date: 2024.04.25 10:06:41 -04'00'

JOHN OMSLAER, P.E.
 E.B. #28829 | LICENSE #52733
 DYNAMIC ENGINEERING SOLUTIONS INC
 1950 NE 6th Street #10075
 Pompano Beach, Florida 33061
 OFFICE (954) 860-5263

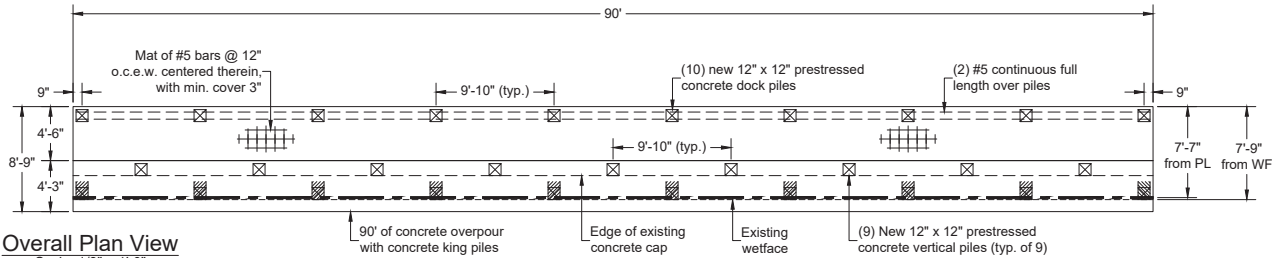

Overall Plan View
Scale: 1/8" = 1'-0"

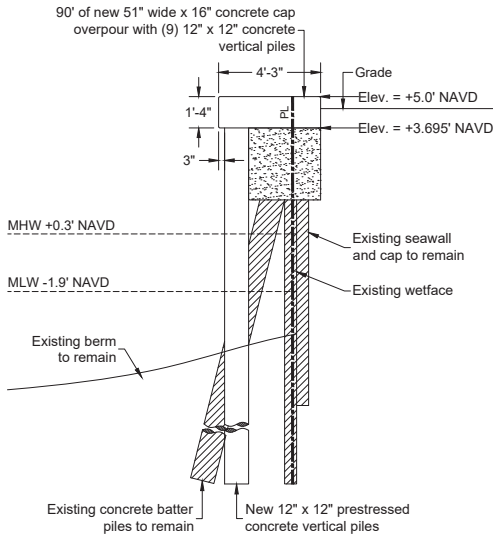

Seawall Section
Scale 1/4" = 1'-0"

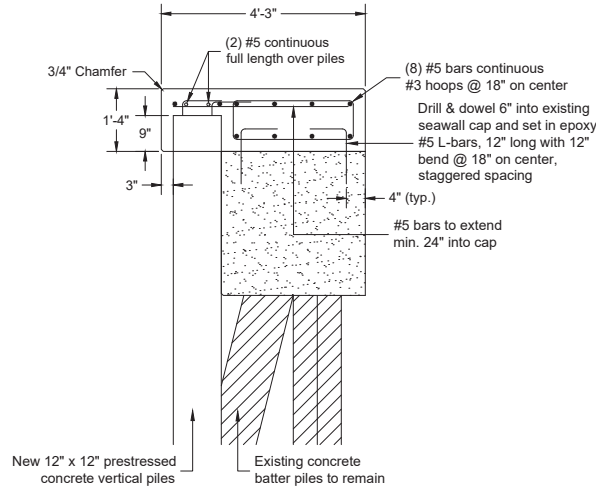

Cap Steel Detail
Scale: 1/2" = 1'-0"

Consultant
UNLIMITED PERMIT SERVICES, INC
Marine Design & Consulting
902 NE 1st Street #2
Pompano Beach, FL 33060
(954) 532-0129
Office@unlimitedps.net

Project Engineer
DYNAMIC ENGINEERING SOLUTIONS, INC
1950 NE 6 Street #10075
Pompano Beach, FL 33061
Office: (954) 860-5263

Contractor
THE DOCK EXPERTS
2670 North Federal Highway
Lighthouse Point, FL 33064
(754) 200-4852
CGC1527192 & SCC131152145

Project Information
Seawall Repair / New Dock
Larry Cook
2860 NE 9 Street
Pompano Beach, FL 33062

DATE
4-8-24
4-24-24

"This document has been electronically signed and sealed by John H. Omslaer, P.E. on date noted using a SHA-1 authentication code. Printed copies are not considered signed and sealed and the SHA-1 authentication code per must be verified on any electronic copies per Rule 62-30.060, F.A.C."

Digitally signed by John H Omslaer
Date: 2024.04.25 10:07:03 -04'00'

JOHN OMSLAER, P.E.
E.B. #28829 | LICENSE #52733
DYNAMIC ENGINEERING SOLUTIONS INC
1950 NE 6th Street #10075
Pompano Beach, Florida 33061
OFFICE (954) 860-5263

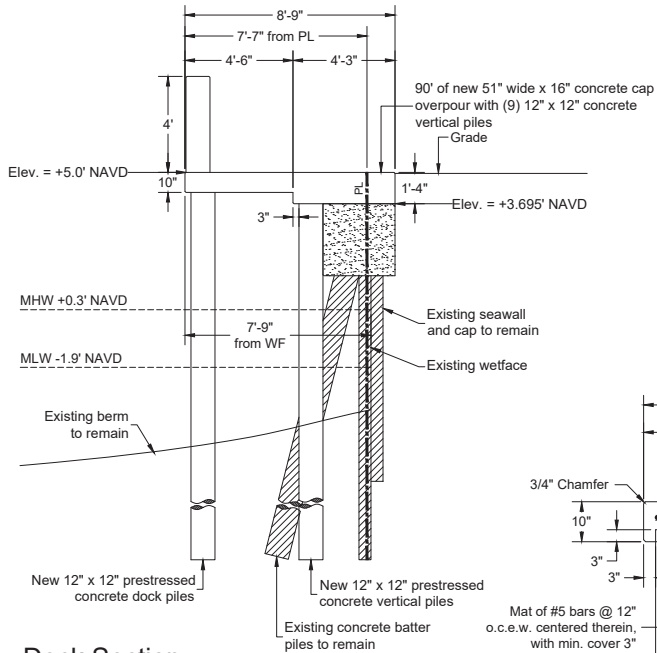

Dock Section

Scale 1/4" = 1'-0"

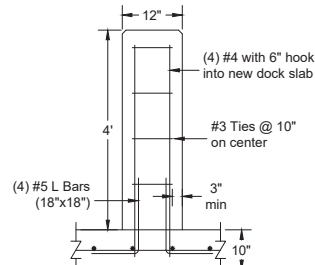

Column Detail

Scale: 1/4" = 1'-0"

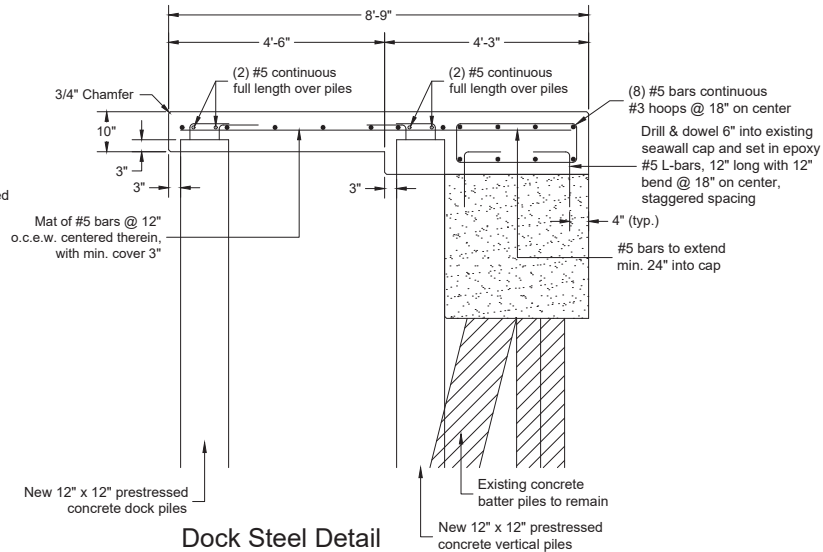

Dock Steel Detail

Scale: 1/2" = 1'-0"

Consultant

UNLIMITED PERMIT SERVICES, INC
 Marine Design & Consulting
 902 NE 1st Street #2
 Pompano Beach, FL 33060
 (954) 532-0129
 Office@unlimitedps.net

Project Engineer

DYNAMIC ENGINEERING SOLUTIONS, INC
 1950 NE 6 Street #10075
 Pompano Beach, FL 33061
 Office: (954) 860-5263

Contractor

THE DOCK EXPERTS
 2670 North Federal Highway
 Lighthouse Point, FL 33064
 (754) 200-4852
 CGC1527192 & SCC131152145

Project Information

Seawall Repair / New Dock
 Larry Cook
 2860 NE 9 Street
 Pompano Beach, FL 33062

DATE

4-8-24

4-24-24

This document has been electronically signed and sealed by John H. Omslaer, P.E. on date noted using a SHA-1 authentication code. Printed copies are not considered signed and sealed and the SHA-1 authentication code must be verified on any electronic copies per Rule 62-30.060, F.A.C.

John H Omslaer Digitally signed by John H Omslaer
 Date: 2024.04.25 10:07:26 -04'00'

JOHN OMSLAER, P.E.
 E.B. #28829 | LICENSE #52733

DYNAMIC ENGINEERING SOLUTIONS INC
 1950 NE 6th Street #10075
 Pompano Beach, Florida 33061
 OFFICE (954) 860-5263

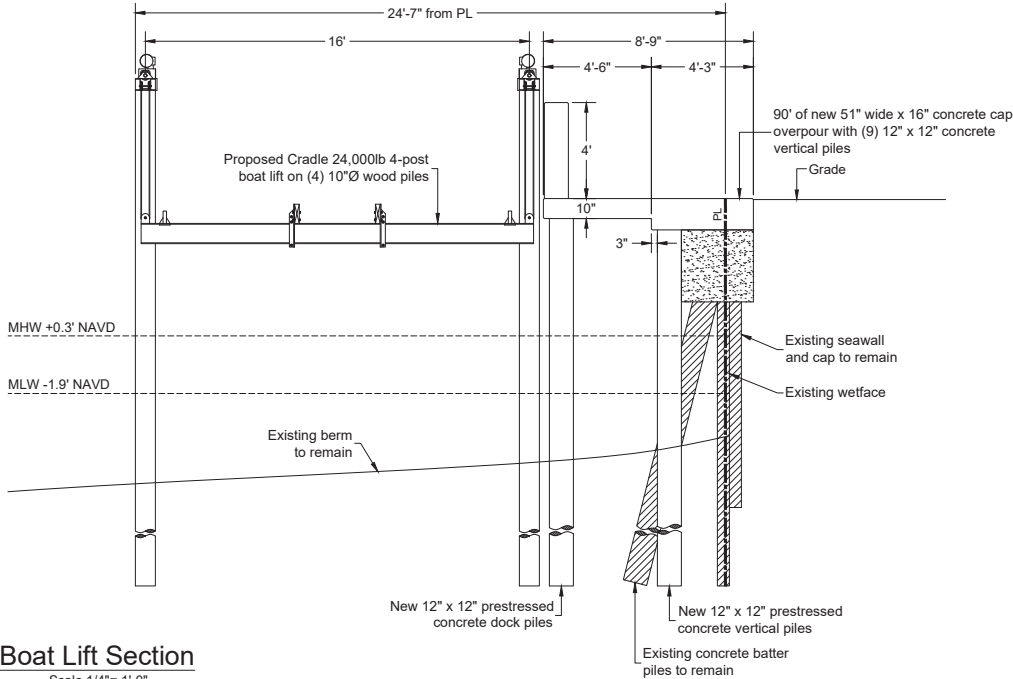

Boat Lift Section

Scale 1/4" = 1'-0"

Consultant
UNLIMITED PERMIT SERVICES, INC
 Marine Design & Consulting
 902 NE 1st Street #2
 Pompano Beach, FL 33060
 (954) 532-0129
 Office@unlimiteddps.net

Project Engineer
DYNAMIC ENGINEERING SOLUTIONS, INC
 1950 NE 6 Street #10075
 Pompano Beach, FL 33061
 Office: (954) 860-5263

Contractor
THE DOCK EXPERTS
 2670 North Federal Highway
 Lighthouse Point, FL 33064
 (754) 200-4852
 CGC1527192 & SCC131152145

Project Information
Seawall Repair / New Dock
 Larry Cook
 2860 NE 9 Street
 Pompano Beach, FL 33062

DATE
4-8-24
4-24-24

"This document has been electronically signed and sealed by John H. Ormslaer, P.E. on date noted using a SHA-1 authentication code. Printed copies are not considered signed and sealed and the SHA-1 authentication code must be verified on any electronic copies per Rule 62-30.060, F.A.C."

John H Ormslaer
 Digitally signed by John H Ormslaer
 Date: 2024.04.25 10:07:54 -04'00'

JOHN ORMSLAER, P.E.
 E.B. #26829 | LICENSE #52733
 DYNAMIC ENGINEERING SOLUTIONS INC
 1950 NE 6th Street #10075
 Pompano Beach, Florida 33061
 OFFICE (954) 860-5263

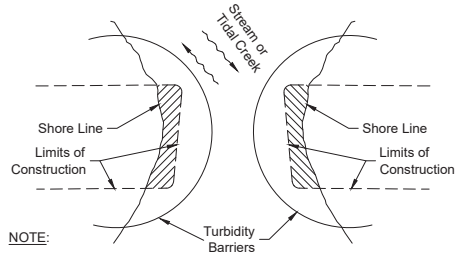
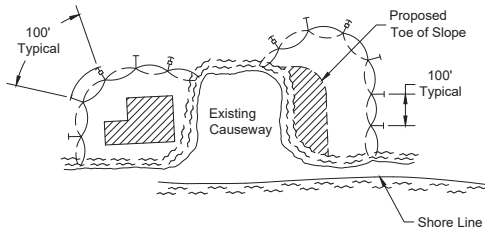

NOTE:
Turbidity barriers for flowing streams and tidal creeks may be either floating, or staked types or any combinations of types that will suit site conditions and meet erosion control and water quality requirements. The barrier type(s) will be at the Contractor's option unless otherwise specified in the plans, however payment will be under the pay item(s) established in the plans for Floating Turbidity Barrier and/or Staked Turbidity Barrier. Posts in staked turbidity barriers to be installed in vertical position unless otherwise directed by the Engineer of Record.

- LEGEND**
- Pile Locations
 - Dredge or Fill Area
 - Mooring Buoy with Anchor
 - Anchor
 - Barrier Movement Due To Current Action
 - Stake or Anchor every 100' (typical)

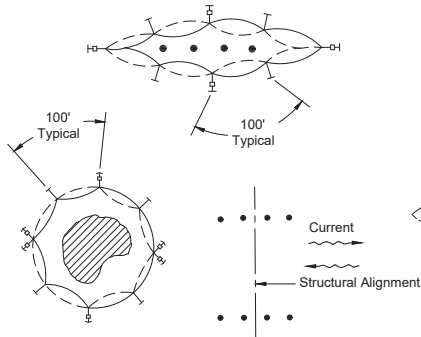

- NOTES:**
- Turbidity barriers are to be used in all permanent bodies of water regardless of water depth.
 - Number and spacing of anchors dependent on current velocities.
 - Deployment of barrier around pile locations may vary to accommodate construction operations.
 - Navigation may require segmenting barrier during construction operations.
 - For additional information see Section 104 of the Standard Specifications.

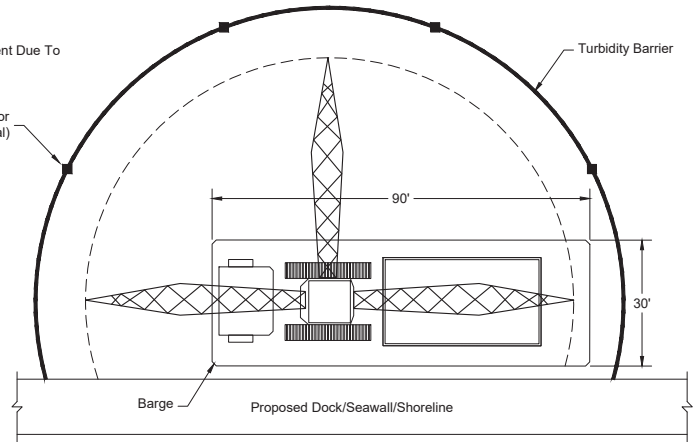

TURBIDITY BARRIER APPLICATIONS

Consultant
UNLIMITED PERMIT SERVICES, INC
Marine Design & Consulting
902 NE 1st Street #2
Pompano Beach, FL 33060
(954) 532-0129
Office@unlimitedps.net

Project Engineer
DYNAMIC ENGINEERING SOLUTIONS, INC
1950 NE 6 Street #10075
Pompano Beach, FL 33061
Office: (954) 860-5263

Contractor
THE DOCK EXPERTS
2670 North Federal Highway
Lighthouse Point, FL 33064
(754) 200-4852
CGC1527192 & SCC131152145

Project Information
Seawall Repair / New Dock
Larry Cook
2860 NE 9 Street
Pompano Beach, FL 33062

DATE
4-8-24
4-24-24

"This document has been electronically signed and sealed by John H. Omslaer, P.E. on date noted using a SHA-1 authentication code. Printed copies are not considered signed and sealed and the SHA-1 authentication code must be verified on any electronic copies per Rule 62-30.080, F.A.C."

John H Omslaer Digitally signed by John H Omslaer
Date: 2024.04.25 10:08:59 -04'00'

JOHN OMSLAER, P.E.
E.B. #28829 | LICENSE #52733
DYNAMIC ENGINEERING SOLUTIONS INC
1950 NE 6th Street #10075
Pompano Beach, Florida 33061
OFFICE (954) 860-5263

GENERAL NOTES:

1. Construction to follow the Florida Building Code 8th Edition (2023) and amendments as applicable and all Local, State and Federal Laws.
2. Licensed contractor shall verify the existing conditions prior to the commencement of the work. Any conflicts or omissions between existing conditions or the various elements of the working drawing shall be brought to the attention of the Engineer prior to the commencement of the work. The Licensed Contractor and all subcontractors are responsible for all lines, elevations, and measurements in connection with their work.
3. Do not scale drawings for dimensions.
4. Any deviation and/or substitution from the information provided herein shall be submitted to the Engineer for approval prior to commencement of work.
5. All unanticipated or unforeseen demolition and/or new construction conditions which require deviation from the plans and notes herein shall be reported to the Engineer prior to commencement of work.
6. All new work and/or materials shall conform to all requirements of each administrative body having jurisdiction in each appertaining circumstance.
7. All new materials and/or patchwork shall be provided to match existing materials and/or adjoining work where practical except as specifically noted herein.
8. Licensed Contractor to shall use all possible care to protect all existing materials, surfaces, and furnishings from damage during all phases of construction.
9. Licensed Contractor to verify location of existing utilities prior to commencing work.
10. The Licensed contractor to install and remove all shoring and bracing as required for the proper execution of the work.
11. Licensed Contractor to obtain all permits as necessary from all Local, State, and Federal agencies.
12. Turbidity barriers to be marked with site contractor's company name using permanent markings no smaller than 3 inches in height on the top of the barrier.

PILE DRIVING:

1. Piles shall be driven using an approved cushion block consisting of material so arranged so as to provide the transmission of hammer energy.
2. Piles shall be driven to a minimum allowable bearing capacity of 10 tons for wood, 25 tons for concrete, and 5 tons for pin piles, a minimum of 8' into berm or refusal.
3. Piles shall be driven with a drop hammer or gravity hammer provided the hammer shall weight no less than 3,000 pounds, and the fall of the hammer shall not exceed 6'.
4. Piles shall be driven with a variation of not more than $\frac{1}{4}$ inch per foot from the vertical, or from the batter line indicated, with a maximum variation of the head of the pile from the position shown on the plans of not more than three inches.
5. Where piling must penetrate strata offering high resistance to driving, the structural engineer of record or special inspector may require that the piles be set in pre-drilled or punched holes. The piles shall reach their final penetration by driving.

CONCRETE NOTES:

1. Concrete shall conform to ACI 318-14 and shall be regular weight, sulfate resistant, with a design strength of 5000 psi at 28 days with a maximum water-cementitious materials ratio, by weight aggregate concrete of 0.40.
2. Owner shall employ and pay for testing services from an independent testing laboratory for concrete sampling and testing in accordance with ASTM.
3. Licensed contractor is responsible for the adequacy of forms and shoring and for safe practice in their use and removal.
4. Concrete cover shall be 3" unless otherwise noted on the approved drawings.
5. Reinforcing steel shall be in conformance with the latest version of ASTM A615 Grade 60 specifications. All reinforcement shall be placed in accordance with ACI 315 and ACI Manual of Standard Practice.
6. Splices in reinforcing bars shall be not be less than 48 bar diameters and reinforcing shall be continuous around all corners and changes in direction. Continuity shall be provided at corners or changes in direction by bending the longitudinal steel around the corner 48 bar diameters.
7. Defective, cracked or loose concrete areas must be cut out, the rebar must be cleaned, coated with zinc and repaired with at least 3" of epoxy-concrete mix or gunnite concrete with sulfate-resistant cement.

PILE NOTES:

1. Concrete piles shall attain 6000 psi compressive strength in 28 days.
2. Concrete piles shall be reinforced with four - $\frac{7}{16}$ "Ø lo-lax strands, 270 kips, and 5 ga. spiral ties.
3. Concrete piles shall be 12"x12" square, minimum length of 20'.
4. Concrete piles shall be cut to leave strands exposed a min. of 18" and tied to dock or cap steel or drill and epoxy (2) #5 12"x18" hook bars 6" into pile.

Consultant
UNLIMITED PERMIT SERVICES, INC
 Marine Design & Consulting
 902 NE 1st Street #2
 Pompano Beach, FL 33060
 (954) 532-0129
 Office@unlimitedps.net

Project Engineer
DYNAMIC ENGINEERING SOLUTIONS, INC
 1950 NE 6 Street #10075
 Pompano Beach, FL 33061
 Office: (954) 860-5263

Contractor
THE DOCK EXPERTS
 2670 North Federal Highway
 Lighthouse Point, FL 33064
 (754) 200-4852
 CGC1527192 & SCC131152145

Project Information
Seawall Repair / New Dock
 Larry Cook
 2860 NE 9 Street
 Pompano Beach, FL 33062

DATE
4-8-24
4-24-24

This document has been electronically signed and sealed by John H. Omslaer, P.E. on date noted using a SHA-1 authentication code. Printed copies are not considered signed and sealed and the SHA-1 authentication code must be verified on any electronic copies per Rule 62-30.080, F.A.C.

John H Omslaer Digitally signed by John H Omslaer
 Date: 2024.04.25 10:09:25 -04'00'

JOHN OMSLAER, P.E.
 E.B. #28829 | LICENSE #52733
 DYNAMIC ENGINEERING SOLUTIONS INC
 1950 NE 6th Street #10075
 Pompano Beach, Florida 33061
 OFFICE (954) 860-5263