



HIDDEN HARBOUR

APPLICATION FOR PLANNED DEVELOPMENT (PD-I)
MODIFICATION TO MIXED-USE COMPONENT

P&Z

PZ21-1300006
1/26/2022



HIDDEN HARBOUR, POMPANO BEACH, FL.
SEPTEMBER 27TH, 2021

PREPARED FOR:

CITY OF POMPANO BEACH

SUBMITTED BY:

APPLICANT NAME

AMP IV HIDDEN HARBOUR LLC
2890 NE 187 STREET
AVENTURA, FL. 33180

P&Z

PZ21-13000006
1/26/2022

PROJECT TEAM:

DEVELOPMENT TEAM



Chris Suarez
3225 Aviation Avenue, 6th Floor
Coconut Grove, FL 33133
T: 305.860.8188
E:chriss@htgf.com

DEVELOPMENT TEAM



ANDREW STURNER
2890 NE 187 STREET
AVENTURA, FL. 33180
E: andy@aquamarinepartners.com

ZONING, LAND USE AND ENVIRONMENTAL LAW



GRAHAM PENN
200 S. BISCAYNE BLVD | SUITE 850
MIAMI, FL. 33131
T: 305.377.6229
E: gpenn@brzoninglaw.com

ARCHITECT



BEATRIZ M. HERNANDEZ
8950 SW 74 COURT | SUITE 1513
MIAMI, FL. 33156
T: 305.273.9911
E: bhernandez@msaarchitectsinc.com

CIVIL ENGINEER



DAMON T. RICKS
241 COMMERCIAL BLVD I
LAUDERDALE-BY-THE-SEA, FL. 33308
T: 954.522.1004
E: dtricks@flynnengineering.com

LANDSCAPE ARCHITECT



Hugh Johnson, RLA / Principal
612 SW 4th Ave, Fort Lauderdale,
FL 33315
Direct Line: 954.764.8858 ext. 20
Cell: 954.249.1136
E: hjohnson@archall.net

TRAFFIC



JOAQUIN VARGAS
8400 N. UNIVERSITY DR | #307
TAMARAC, FL. 33321
T: 954.582.0988
E: joaquin@traftech.biz



P&Z

PZ21-13000006
HIDDEN HARBOUR
1/20/2022

I. INTRODUCTION	
A. PURPOSE & INTENT	6
B. PROJECT SIZE & LOCATION	6
C. FUTURE LAND USE ZONING	6
II. GENERAL STANDARDS FOR PLANNED DEVELOPMENT	
A. (PD) PLAN	7
B. CONSISTENCY WITH CITY PLANS	12
C. COMPATIBILITY WITH SURROUNDING AREAS	12
D. DEDICATIONS / VACATIONS	13
E. PD AGREEMENT	13
III. PLANNED DEVELOPMENT INFILL (PD-I)	
A. PLANNING OBJECTIVE	14
B. PURPOSE	14
C. USE STANDARDS	15
D. CONVERSION AND FLEXIBILITY	19
E. INTENSITY AND DIMENSIONAL STANDARDS	19
F. MODIFICATIONS / DEVIATIONS	22
G. OFF-STREET PARKING REQUIREMENTS	23
IV. EXHIBITS	
EXHIBIT A1: LOCATION MAP	
EXHIBIT A2: SURVEY	
EXHIBIT B: LEGAL DESCRIPTION	
EXHIBIT C: CURRENT ZONING	
EXHIBIT D: EXISTING/PROPOSED ZONING	
EXHIBIT E1: PD MASTER PLAN + MASTER PLAN DATA	
EXHIBIT E2: SHADOW STUDIES	
EXHIBIT E3: UTILITIES MASTERPLAN	
EXHIBIT F: WATER & SEWER AVAILABILITY LETTERS	
EXHIBIT G: DECLARATION OF RESTRICTIONS	
EXHIBIT H: STREET SECTIONS	
EXHIBIT I: SCHOOL CONSISTENCY REVIEW REPORT	
EXHIBIT J: CORRIDOR VIEW DIMENSIONS	
EXHIBIT K: AIRPORT AIRSPACE HEIGHT LIMIT	
EXHIBIT L: TRUCK TURNING RADIUS	

INTRODUCTION

PURPOSE AND INTENT

The Hidden Harbour assemblage that forms the Planned Development (“PD”) site offers a unique opportunity to link together new residential development with historically important water-serving uses along one of the City’s most important corridors. The application implements the vision approved through the “Transformation Plan” portion of the City’s Transportation Corridor Study completed over the last several years.

Relevant Development History: The majority of the Property was most recently rezoned in early 2020, which applied a Planned Development Infill (PD-I) zoning to the project. The approved planned development consists of two major components: (1) a marina/boat yard/boat storage use east of NE 23 Avenue; (2) mixed use development along Federal Highway and NE 16 Street; and (3) a valet parking lot and private green space north of NE 16 Street.

The maximum building heights ranged from nine stories and 90 feet to three stories and 35 feet. The building along Federal Highway was approved at 90 feet and the building along NE 16 Street transitioned from nine stories and 90 feet, to three stories and 35 feet. The parking for the mixed-use component

PROJECT SIZE AND LOCATION

The Hidden Harbour PD is 7.19 net acres and is located generally south of NE 16 Street and east of Federal Highway. The Mixed-Use Component of the PD is 2.78 acres.

FUTURE LAND USE AND ZONING

The Hidden Harbour PD is designated “Mixed-Use High (MUR 50)” and is currently zoned PCD-3. The Hidden Harbour PD is designated “Mixed-Use High” (MUR 50) and “Low-Medium Density Residential” (LM) and is currently zoned a mix of PDI and RD-1.

GENERAL STANDARDS FOR PLANNED DEVELOPMENT

(PD) PLAN

1. PLANNING OBJECTIVE

The Hidden Harbour PD is consistent with the goals of the PD-I district in that it proposes a high-quality, mixed- use development on a relatively small site. Its use limitations and development standards will ensure that the infill development is compatible with both surrounding existing developments.

2. GENERAL DEVELOPMENT AREAS

The Hidden Harbour PD will be a single development area, subject to the following agreed-to restrictions:

1. The area east of NE 23 Avenue and south of the waterway will be limited to non-residential marina uses.
2. The area north of NE 16 Street will be limited to parking and shall be open to the public
3. The remainder of the PD will be eligible for mixed use development.

TABLE I	
LAND USE PLAN LIMITS	
Area 1	Marina Use (including boat storage, boat repair, and slips): 75,000 square feet and 15 wet slips
Area 2	Private Park (Open to Public) / Parking
Area 3	Multi-Family Residential: 300 units Commercial Development (including, but not limited to, boat sales, offices, showrooms, and related uses): 510,000 square feet

3. TYPES AND MIX OF USES

The type and mix of uses, number of residential units (by use type), nonresidential floor area (by use type), and density are depicted on **Exhibit E1: PD Master Plan** and below.

TABLE II	
Type and Mix of Uses	
Residential	Up to 300 Units Max.
Commercial	Minimum of 65,000 square feet, including a minimum of 10,000 square feet of commercial uses vertically integrated in a mixed-use building fronting on Federal Highway
Total Floor Area	Maximum of 650,000 square feet

4. OPEN SPACE

The PD plan proposes both active and passive open space. Active open space will include the waterfront promenade and other pedestrian areas throughout the PD. Passive open space will include buffering landscape designed to allow for a transition between publicly-accessible areas and private areas, perimeter landscape buffers and the potential park area which shall be open to the public.

5. NATURAL FEATURES

The PD site is urban in character, with the only natural feature of any consequence being the waterway (Caliban Canal) that divides the site north to south on the east side of NE 23 Avenue. The PD plan has been designed to encourage public pedestrian access to the waterway, both along NE 23 Avenue and along the north side of the waterway.

6. ACCESS, TRANSPORTATION, AND CIRCULATION

Vehicular access to the site will be from Federal Highway, NE 23 Avenue, and NE 16 Street. Parking for the mixed-use development is proposed to be located in two garages: (1) a large structure along Federal Highway on the southern end of the Property; and (2) a smaller structure located on the north side of NE 16 Street designed to serve the building on the south side of NE 16 Street. A deceleration lane has been provided along Federal Highway for Northbound traffic turning into a private driveway. The marina parking will be located, as it does now, around the existing marina building.

A drop off is provided off of NE 16th Street to provide for Uber, Lyft or the like as a drop off and pick up area for residents living in this building. Sufficient queuing area as well as bypass space shall be provided to meet the intended use of this drop off area. At time of site plan approval, the project shall demonstrate the compliance through a queuing analysis performed by a traffic engineer.

Loading and trash have been centrally located, as far away as possible from nearby residential uses. All loading and trash areas are proposed to be accessed from NE 23 Avenue.

The Applicant will coordinate the provision of transit amenities with Broward County Transit and has agreed to provide a water taxi stop on the site, subject to City approval.

7. POTABLE WATER AND WASTEWATER

The project will be served by City of Pompano Beach existing 8" water main located within NE 23rd Avenue adjacent to the project location. Additionally an existing 12" water main is available for connection along Federal Highway adjacent to the project.

A City of Pompano Beach existing 18" gravity sewer service is available within the NE 23rd Avenue right of way adjacent to the project for wastewater connection. The location of proposed on-site potable water and wastewater will be identified on subsequent water and sewer plans.

8. STORMWATER MANAGEMENT

The City of Pompano Beach is not located in a drainage or flood control district. The project will have on-site storm drainage. This may include underground piping, exfiltration trenches, catch basins, discharge wells. The existing local streets may have existing storm drainage maintained by the City. All improvements required to meet the adopted level of service will be installed by the applicant in conjunction with new development. Development within the project site will be required to meet the drainage standards of the City of Pompano Beach, Broward County Department of Planning and Environmental Protection, and the South Florida Water Management District. The amendment site will meet the adopted level of service for development within the site.

9. ON-SITE PUBLIC FACILITIES

The Applicant has proposed to provide transit amenities to the County. The plan includes significant public access to the waterway on the east side of NE 23 Avenue and along the north end of the waterway.

10. SUSTAINABLE DESIGN

As a means of addressing the constant and rapid challenging change in global climate, we focused on many sustainable design components of the proposed project with a prime purpose to ensure a high quality of life for future city residents, protect natural resources, and promote sustainable development practices.

The main objective of the proposed site and building design configurations is to stimulate a vital landscape, support public health and safety, increase the development's sustainability and ultimately reducing the negative impact on the environment and boost the health and comfort of the development's end users.

In accordance with Section 155.5802 – Table 155.5802: Sustainable Development options and Points – Many Points will be achieved for the proposed development by implementing main key Green Design features.

As per 155.5802.a.3: Minimum required points=12 points
 Minimum applied/ implemented= 20 points as follows:

- Efficient Cooling: All air conditioners are Energy Star qualified. Points =2
- Hurricane Resistant Structures: The principal building is constructed to meet increased wind loads - 150 mph load minimum. Points =4
- Infill or Mixed Use Development: The development constitutes infill development and/or mixed use development: The development constitutes infill development and/or mixed use development. Points =4
- Overhangs: Overhangs are present on all south windows for energy efficiency purposes. Points =2
- Parking Structure: At least 75 percent of the development's total number of required off-street parking spaces is contained in a parking deck or garage. Points =2
- Parking Structure, Green: At least 75 percent of the development's total number of required off-street parking spaces is contained in a parking deck or garage and at least 15 percent of the total surface area of the top of the parking structure is a green roof. Partial points should be granted. Points =2
- Permeable Sidewalk Surfaces: Permeable or natural surfacing materials are used for all sidewalks. Points =2
- White Roof: All roof surfaces are painted white. Points =2

TOTAL POINTS = 20

In addition, the project shall feasibly incorporate elements in the below listed "Green building" Practices as well as sustainable design features and materials that would satisfy LEED, FGBC, NAHB rating criteria:

- Public Transportation access
- SEER 16 AC equipment or better
- ENERGY STAR rated appliances
- ENERGY STAR rated exhaust fans
- CO2 detectors in each unit
- Use non-HDFC refrigerants
- Exterior lighting to be ENERGY STAR rated or LED fixtures
- Exterior light fixtures to be Dark Sky compliant
- Interior Lighting fixtures to be ENERGY STAR rated or fitted with fluorescent bulbs with the ENERGY STAR label or LED fixtures
- ENERGY STAR Qualified ceiling fans
- Low-Flow toilets, bathtubs/ showers and faucets
- No unvented combustion appliances
- Low VOC paint, adhesives and sealants
- Green Label Plus flooring where feasible
- Drought tolerant as well as native plant material
- Roof framing at 24" O.C. or greater
- All drop soffits and Fascias to be framed with light gage framing at greater than 16" O.C.
- Using post-consumer recycled content or post-industrial recycled content where possible

Note: The development intend to seek NGBS certification due to The Department of Housing and Urban Development



11. ENVIRONMENTAL & POLLUTION CONTROL

1. Contractor shall adhere to the national pollution discharge elimination system (npdes) requirements. The contractor shall institute best management practices (bmps) to ensure compliance with the npdes program and to minimize the impact to public stormwater facilities. A notice of intent (noi) shall be filed prior to start construction activities.
2. Prior to demolition activities, contractor shall install pollution prevention control devices (I.E.), Silt barriers, sediment basins, turbidity barriers around stormwater outfalls on the waterside of lakes, ponds, canals, or waterways, silt screens, etc. according to the approved SWPPP and as recommended by The Florida Department of Environmental Protection (DEP) latest guidelines and permitting requirements.
3. Prior to demolition activities, a silt fence in accordance with the approved SWPPP details and latest DEP standards shall be erected around the site property lines. All public inlets surrounding the site shall be protected by the installation of filter fabric into the frame and grate or other approved BMPS to protect against storm runoff.
4. Pollution control installations, as approved and shown in the SWPPP, shall be maintained throughout demolition and construction periods until the project has been completed and approved by city engineering inspector or project engineer.
5. Contractor shall inspect the pollution control devices daily for signs of malfunction, failure, or needed repairs, and shall make remedial actions immediately upon discovery.
6. Existing stormwater inlets, catch basins, or manholes, onsite and offsite, shall be protected from sediment storm runoff from the proposed demolitions and construction activities.
7. Contractor shall immediately remove all mud, dirt, or other materials tracked or spilled onto existing roads and facilities due to demolition or construction activities from the proposed development.
8. In order to minimize the amount of sediments, mud, and dust transported onto public roadways by the construction vehicles or runoff, the contractor shall install stabilized temporary construction entrance(s) from the construction site as recommended by FDEP. Each temporary construction entrance is a stabilized 6 inch thick layer of 2 to 3 inch course aggregate stone, 12" minimum width, and length to accommodate a minimum of one trucking vehicle.
 - I. The entrance shall be maintained periodically as conditions demand in a condition that will prevent tracking or flowing of sediments onto public rights-of-way. Sediment shall be trapped in cleanout areas and properly handled as onsite debris per applicable state regulations.
 - I. When necessary, vehicle wheels shall be cleaned prior to entrance onto public right-of-way.
 - III. All materials spilled, dropped, washed or tracked from vehicles onto roadways or into public storm drains must be removed by the contractor immediately.
 - IV. Trucks shall not 'cut corners' where the construction exit meets the roadways.
 - V. Sweeping of public roadways shall be done periodically as condition demand.
9. Dust generated from construction shall be minimized by daily watering of the site.
10. Contractor shall provide an erosion and sedimentation control inspector to inspect all points of discharge into nearby waterbodies to record the condition of discharge points, integrity of silt fence and pollution control devices, dust control measures, vehicular traffic and construction material storage and disposal. Written record of all inspections shall be stored by the contractor during demolition and construction periods and shall be submitted to city inspectors upon request. The inspection report shall include at a minimum the following information:
 - I. Name of inspector and his/her qualifications in erosion and sedimentation control
 - II. Date of the inspection

- III. Rainfall rate
- IV. Observations about the SWPP
- V. Actions taken by contractor for all incidents of noncompliance with permit(s)
- VI. Certification that the facility is in compliance with the swpp and permit(s)

CONSISTENCY WITH CITY PLANS

As noted above, a “Corridor Study” has been conducted reviewing all of the City’s major corridors. Among the transformation strategies listed in the Corridor Study is the encouragement of mixed-use development, especially in the area known as the “Hub,” located around NE 15 Street. The Study recognizes that this area is a prime location for mixed-use development that takes advantage of existing marine uses. The instant application is directly supportive of the City’s policy.

The PD Plan is also consistent with the density, intensity, use, and design requirements of the County’s “Pompano Beach Hidden Harbour Activity Center” and the City’s Mixed-High (MUR-50) Comprehensive Plan Designations.

COMPATIBILITY WITH SURROUNDING AREAS

The proposed development will exist in harmony with the surrounding sites while establishing its own identity and creating a sense of anchor for the area.

The unique site’s exposure to Caliban Canal to the South/ East, the Golf Course to the West and the Promenade to the North East provides valuable opportunities for establishing various visual and social connections including: Aqua – Marina/Canal-water, tranquil lush-Green Golf Course, urban Multi Family core with Marina Retail & Restaurant/ Café accents and a Pedestrian Promenade at the North East.

The subject site is designed to highlight and use these diverse social & visual points while balancing a compatibility of landscape, form, height, massing, scale, material, building design and context with the surrounding areas to enrich the future residents and City visitors experience and create a feel of a community with a main Hub.

The subject site is being developed in a manner that recognizes the desirability of increasing the residential use in the area in a manner that respects the existing landscape and building fabric while developing new appropriate typologies connecting/ transitioning the existing commercial centers along N. Federal Highway to the East residential sites.

Fronting N.E. 16th Street just East of NE 23rd Avenue, the mainly residential component of the subject site mirror the existing low rise adjacent property heights through a series of proposed height differences that step back the building from the Eastern most property line. The building “step back” begins with a three (3) story section on the Easternmost portion of the site, steps up to six (6) stories at no closer than 50’ from the East property line, an addition step back up to eight (8) stories at no closer than seventy-five (75’) from the East property line, which connects to the main hub of the development. This step in massing and scale responds to not only the compatibility of the surrounding area but places the bulk of the development along Federal Highway in a separate building on the West side of N.E. 23rd Avenue. This building placement achieves a more urban connection along this corridor while maximizing view corridors and visual exposures to both the Caliban canal to the East and the existing golf course to the West. The final portion of the mixed-use development along Federal highway connects to a eight (8) story parking garage that provides rooftop amenities for the residential portion of the development.

The amenity area will feature and shall not be limited to a recreational pool, amenity deck and lounge areas for residents of the development.

The north side of NE 16 Street is proposed to be developed with a three (3) story parking structure serving the building on the south side of NE 16 Street. The proposed structure has been designed to be compatible in size and design with both the mixed-use development and the surrounding development.

The subject site is carefully planned with intended vertical variation to respect the various existing heights of adjacent residential and commercial uses and promote an environment of complementary mixed uses while ensuring that the intended residential use of the subject site is not adversely impacted.

The PD Site is also uniquely located where a mixed-use development can be compatible with surrounding uses on the corridor. The currently undeveloped portions of the property are largely located against Federal Highway and are buffered from lower density residential uses by the existing marine uses and NE 23 Avenue. The portions of the PD Plan that are closer to smaller multi-family and single-family uses have been limited by both design and use to reduce impact on these areas.

As part of the Land Use Plan Amendment Process (City Application 15-91000001), the Applicant agreed to the following Design Guidelines. These Guidelines have been implemented in the PD plan. The Guidelines are as follows:

1. Buildings will have minimal setbacks and directly address surrounding streets in order to delineate streetwalls.
2. All new buildings abutting Federal Highway will have their primary frontage on that right of way and will include elements to create an interesting experience for pedestrian activity, including transparent glazing, architectural features or both on the first floor of a building fronting toward the street, wider sidewalks, and street furniture.
3. Buildings shall be designed and oriented to encourage pedestrian activity along Federal Highway and NE 23 Avenue.
4. At least 10,000 square feet of commercial use will be vertically integrated with multi-family uses for the portion of the Amendment Site fronting on Federal Highway
5. Pedestrian access points shall be provided across NE 15 Street, NE 16 Street, and NE 23 Avenue in a manner to encourage access to and from the development. Subject to the appropriate governmental approvals, the Applicant will integrate traffic calming solutions on NE 23 Avenue.
6. One or more physical or visual connections between Federal Highway and the waterway will be provided.
7. Short term and long-term bicycle parking will be provided.
8. Dumpsters and loading areas shall be located away from existing residential property to the greatest extent possible.
9. Subject to the appropriate governmental approvals, transit amenities, such as an enhanced bus stop, shall be provided.

The Proposed Master Plan incorporates all of the above Design Guidelines.

DEDICATIONS / VACATIONS

No right of way vacation or significant dedication of land is anticipated by the applicant

PLANNED DEVELOPMENT INFILL (PD-I)

PLANNING OBJECTIVE

The design essence of the proposed development under the Planned Development Infill (PD-I) district is being developed in a manner that uses innovative and creative design principles to provide a mix of different uses of residential and commercial components in close proximity to one another.

It also serves as a communal amenity core bridging the building blocks with the surrounding areas and providing an intimately scaled interface between the private and semi-private realms of the development.

The proposed project implements building design principles focused on promoting pedestrian/ social activities and supporting multi-modal transportation options.

PURPOSE

The purpose of the Hidden Harbour PD is to implement the City's Mixed-Use High (MUR-50) Land Use Designation as well as the County's "Pompano Beach Hidden Harbour Activity Center" Land Use Designation.

1. Reducing or diminishing the inflexibility or uniform design that sometimes results from strict application of zoning and development standards designed primarily for individual lots;

The Hidden Harbour Planned Development represents a unique opportunity to bring together active marine uses with new mixed-use residential and commercial development in a manner that would be impossible using the City's traditional zoning districts. The development standards have been crafted to allow mixed-use development to extend across existing lot boundaries.

2. Allowing greater freedom in selecting the means of providing access, open space, and design amenities;

The Hidden Harbour Planned Development standards will allow the Applicant to open up water access to the public in a manner that would not be possible without the flexibility afforded to Planned Development districts. The PD standards will encourage superior pedestrian, bicycle, and transit access to the area while retaining full vehicular access across the site.

3. Allowing greater freedom in providing a well-integrated mix of residential and nonresidential land uses in the same development, including a mix of housing types, lot sizes, and densities;

The Hidden Harbour Planned Development will fully vertically integrate residential and commercial use, including a mix of multi-family unit sizes serving single occupants to families.

4. Allowing more efficient use of land, with smaller networks of streets and utilities, and thereby lowering development and housing costs; and

The Hidden Harbour Planned Development is a compact 7.19 acres in size and uses only existing street infrastructure (subject to additional necessary dedications) in an infill area that has more than adequate utility capacity.

5. Promoting quality design and environmentally sensitive development that respects surrounding established land use character and respects and takes advantage of a site’s natural and man-made features, such as trees, wetlands, floodplains, and historic features.

The Hidden Harbour Planned Development fully integrates and highlights the waterway that forms its central spine. The development plan has also been designed to locate more intense uses away from nearby residential development. As an infill development, the Hidden Harbour Planned Development is consistent with smart planning principles that discourage further urban expansion into existing greenfields.

USE STANDARDS

The permitted uses within the PD-I are outlined in the below consolidated use table.

TABLE III			
CONSOLIDATED USE TABLE			
P = PERMITTED PRINCIPAL USE			
S = USE ALLOWED AS A SPECIAL EXCEPTION			
A = PERMITTED ACCESSORY USE			
T = PERMITTED TEMPORARY USE			
Use Category	Use Type	Permitted	Use-Specific Standards
Household Living Uses	Dwelling, live/work	P	155.4202.A
	Dwelling, multifamily	P	155.4202.C
	Dwelling, mixed-use	P	155. 4202. G
Communication Uses	Telecommunications facility, collocated on existing structure other than telecommunications tower	P	155. 4204. C 155. 4204. D
Day Care Uses	Child Care Facility	P/A	155. 4206. B
Health Care Uses	Medical office	P	155. 4209. A
	Specialty medical facility	P	155. 4209. B
	Urgent care facility 24 hours	P	155. 4209. C



TABLE III			
CONSOLIDATED USE TABLE			
P = PERMITTED PRINCIPAL USE			
S = USE ALLOWED AS A SPECIAL EXCEPTION			
A = PERMITTED ACCESSORY USE			
T = PERMITTED TEMPORARY USE			
Open Space Uses	Park or plaza	P/A	155. 4210. D
Animal Care Uses	Animal grooming	P	155. 4214. A
	Pet shop	P	155. 4214. E
Boat and Marine Sales and Service Uses	Boat dry storage facility	P/A	155. 4215. B
	Boat or marine parts sales without installation	P/A	155. 4215. C
	Boat or marine parts sales with installation	P/A	155. 4215. D
	Boat or marine repair and servicing	P/A	155. 4215. E
	Boat sales or rental	P/A	155. 4215. F
	Boat towing service	P/A	155. 4215. G
	Docking facility, barge	P/A	155. 4215. H
	Docking facility, commercial fishing boat	P/A	155. 4215. I
	Docking facility, recreational boat	P/A	155. 4215. J
	Marina	P/A	155. 4215. K
	Yacht Club	P	155. 4215. L
Commercial or Membership Recreation/ Entertainment Uses	Other indoor commercial or membership recreation/ entertainment use	P/A	155. 4217. M

TABLE III			
CONSOLIDATED USE TABLE			
P = PERMITTED PRINCIPAL USE			
S = USE ALLOWED AS A SPECIAL EXCEPTION			
A = PERMITTED ACCESSORY USE			
T = PERMITTED TEMPORARY USE			
Eating and Drinking Establishments	Bar or lounge	P/A	155. 4218. A
	Brewpub	P/A	155. 4218. B
	Restaurant	P/A	155. 4218. E
	Specialty eating or drinking establishment	P/A	155. 4218. F
Office Uses	Professional office	P	155. 4220. B
Retail Sales and Service Uses - Personal Services	Bank or financial institution	P	155. 4221. C
	Personal services establishment	P	155. 4221. K
	Book or media shop	P	155. 4222. D
	Grocery or convenience store	P/A	155. 4222. F
	Drug store or pharmacy	P	155. 4222. G
	Farmers' market	P	155. 4222. H
	Beer or wine store	P	155. 4222. M
	Retail sales establishment, large	P	155. 4222. P
	Other retail sales establishment	P	155. 4222. R
Visitor Accommodation Uses	Condo hotel	P	155. 4225. A
	Bed and breakfast inn	P	155. 4225. B
	Hotel or motel	P	155. 4225. C
Typical Accessory Uses and Structures	Dock	A	155. 4303. H
	Drop-in child care	A	155. 4303. J
	Electric vehicle (EV) level 1, 2, or 3 charging station	A	155. 4303. K / 155. 4303. L
	Fence or wall	A	155. 4303. O
	Green roof	A	155. 4303. R

TABLE III			
CONSOLIDATED USE TABLE			
P = PERMITTED PRINCIPAL USE S = USE ALLOWED AS A SPECIAL EXCEPTION A = PERMITTED ACCESSORY USE T = PERMITTED TEMPORARY USE			
Typical Accessory Uses and Structures	Home based business	A	155. 4303. S
	Outdoor display of merchandise	A	155. 4303. U
	Outdoor seating, including side-walk cafes (as accessory to eating and drinking establishments)	A	155. 4303. V
	Parking or storage of motor vehicles, recreational vehicles, boats, airboats, or trailers	A	155. 4303. X
	Rainwater cistern or barrel	A	155. 4303. Z
	Retail sales (as accessory uses)	A	155. 4303. BB
	Small wind energy system	A	155. 4303. DD
	Solar energy collection system	A	155. 4303. EE
	Swimming pool or spa or hot tub	A	155.4303. GG
	Mechanical Equipment and similar features	A	155. 4303. JJ
	Uncovered porches, decks, patios, terraces, or walkways	A	155.4303. KK
	Lighting fixtures, projecting or freestanding	A	155.4303. MM
	Eating and drinking establishments (as an accessory use)	A	155.4303.PP
	Farmer's market (as a temporary use)	T	155. 4403. A

CONVERSION AND FLEXIBILITY

CIRCULATION

Proposed road and pedestrian circulation as shown on the PD-I Master Plan are conceptual and can be subject to needed modification to accommodate any changes in the size and configuration of the project design, as long as any such modification maintains a consistent level and quality of access and circulation as illustrated on the Master Plan.

WATERWAYS AND OPEN SPACE

The subject site open space is designed with the intention of optimizing the site potential and creating an intimate loop connecting the various site components from the promenade (North/ East) to the Residential/ Commercial core retail and restaurant/cafes in the center with the Marina (East) and the Golf Course (West) in harmonious way. Through the view corridors provided at many site axis including: Along N.E. 16 ST via the pedestrian promenade and N.E. 23 Ave and through North Federal Highway via N.E. 15th ST Paseo connecting the residents & Visitors from the Golf Course (West) experience to the Caliban Canal (East).

INTENSITY AND DIMENSIONAL STANDARDS

Site specific development standards for the project are provided below and on the PD Master Plan.

TABLE IV	
Intensity and Dimensional Standards	
i. Land area (acres)	
Gross Acres (to CL of ROW - to calc. for density)	9.96 Acres
Gross Acres (including basin for park)	6.90 Acres
Estimated Net Acres (upland area that excludes basin)	6.5 Acres
ii. Type and mix of land uses*	
Multi-Family Residential	300 Units max.
Commercial Development (Including but not limited to: Boat sale, showrooms and related uses	10,000 to 510,000 SQ.FT.
Marine Use (Including: Boat storage, boat repair and slips)	10,000 to 75,000 SQ. FT./ 15 Slips
*Refer to table III for list of additional approved Type of Uses	

TABLE IV			
Intensity and Dimensional Standards			
iii. Maximum number of residential units/ Unit Square Footage Size (SF)	300 du's max		
	min	max	
	1 Bedroom (multi-family)	580 SQFT	800 SF
	2 Bedroom (multi-family)	850 SQFT	1175 SF
3 Bedroom (multi-family)	1,180 SQFT	1,350 SF	
iv. Maximum Commercial -Nonresidential floor area* (Exclusive of Garage)	510, 000 SQ.FT.		
Maximum Marina	75,000 SQ. FT., 15 Slips		
Minority/ Marina Use	Min. of 10% of total floor area		
*Min. 10,000 SQ. FT. of Commercial Use to be vertically integrated into mixed use building			
v. Minimum Lot Area	10,000 SQ. FT.		
vi. Minimum Lot Width	100 FT. FRONTAGE		
vii. Minimum Pervious (Calc. based on Net Acres)	20% (1.27 Acres)		
viii. Maximum Impervious area (Calc. based on Net Acres)	80% (5.23 Acres)		
ix.. Max. Building height	100 ft to 150 ft. Not to Exceed Airport Air Space Max. Height (See Exhibit K)		
x. Max. Individual building size			
Fronting Federal Highway (West of NE 23 rd Ave)	8 Stories Not to Exceed Airport Air Space Max. Height Limits (See Exhibit K)		
Fronting NE 16 th ST (East of NE 23 rd Ave)	3 Stories (35'-0") within first 50'-0" and no less than 10' of east property line / Adjacent to residential.		
	6 Stories no less than 50'-0" of East Property Line / Adjacent to residential.		
	8 Stories no less than 75'-0" of East Property Line / Adjacent to residential.		
Fronting NE 23 rd Ave (South of Caliban Canal)	Existing 1 Story Dry Boat Storage Facility to remain		

TABLE IV		
Intensity and Dimensional Standards		
ix. Setbacks	Min.	Max.
North – Along North Property Lines		
Along NE 16th St.	7'-0"	63'-0"
To 3 Story Garage	10'-0"	20'-0"
East– Along East Property Lines		
To existing Dry Boat Storage facility	59'-0"	61'-0"
Up to 3 Stories Residential	10'-0"	15'-0"
Up to 6 Stories Residential	50'-0"	None
Up to 8 Stories Residential	75'-0"	None
Along 24th Terr to 3 Story Garage	10'-0"	20'-0"
West– Along West Property Lines		
Along Federal Highway	5'-0"	30'-0"
To 3 story Garage	10'-0"	20'-0"
South Along South Property Lines		
To existing Dry Boat Storage Facility	91'-0"	95'-0"
To 8 story Parking Garage	20'-0"	20'-0"
Residential building to Face of bulkhead nose (Caliban Canal)	20'-0"	31'-0"
Face of bulkhead nose to Property line	20'-0"	57'-0"
To 3 story Garage	5'-0"	20'-0"
East & West of N.E. 23Rd Ave	0'-0"	10'-0"
Note: All Buildings' porches, stoops and balconies can project up to 7'-0" into setback or up to ROW Line whichever is less		
Additional Development Standards		
Access and Circulation	As provided in Article 5: Development Standards as provided in Deviations/ Modifications Table V	
Off-Street parking & loading	As provided in Master Parking Table VI	
Landscaping	As provided in Article 5: Development Standards as provided in Deviations/ Modifications Table V	
Tree Preservation		
Screening		
Fences and Walls		
Exterior Lighting		
Commercial and mixed-use design	As provided in Article 5: Development Standards	
Sustainable Design	As provided in Section II.A.10 of PD-I Application	
Signage	As provided in Chapter 156. Sign Code	



MODIFICATIONS / DEVIATIONS

The following table depicts areas that deviate from the proposed PD-I District and applicable standards.

TABLE V						
Deviations/ Modifications						
Type	Code Section	Description	Modification		Justification	
Building Base Planting Standards	155.5203.e.3.a	Required shrubs shall be planted within three feet of the base of the building. If a street sidewalk is located between the base of the building and the street, required shrubs may be planted up to 15 feet from the base of the building.	Except where conflict with pedestrian sidewalks exist.		To accommodate Sidewalks abutting building.	
Access, circulation, parking & loading Driving Aisle	155.5102.I.1	Required Aisle Width Dimensions 23'	22 FT.		To accommodate proposed site design and more efficient traffic circulation in garage.	
Vehicle stacking	155.5101.G.8.B	Parking lot Entrance driveways	Min. 30 FT. stacking distance for 500 or more off-street spaces (as measured from ROW line)		To accommodate proposed site design for vehicular access.	
Dwelling, Multi-Family Parking	155.5102.D.I	For Units on 2 nd floor or higher of a building with non-residential use located on ground level: 1 space per Dwelling Unit (du)	None		Due to Urban Mixed-Use Settings parking demand shall be less.	
		1-2 BD	1.5 Space	1 BD		1 Space
		All other MF 3 BD	2 Spaces	2-3 BD		2 Spaces
			Guest: 10% of Provided Parking			
Landscape between Vehicular Use Areas and Buildings	155.5203.D.5.A	Minimum landscaped area shall be eight feet for each story in the abutting building façade, up to 24 feet	Except where conflict with pedestrian sidewalks exist.		To accommodate Sidewalks abutting building.	

TABLE V				
Deviations/ Modifications				
Type	Code Section	Description	Modification	Justification
Required Buffer Types and Standards	155.5203.F3	Option 1: At Least 10' wide A wall or semi-opaque fence at least 6 feet high 1 Tree per 30 linear feet + a continuous hedge at least 4 feet high on the exterior side of the wall or fence 1 shrub per 10 linear feet on the interior side of the wall or fence	Option 1: At Least 10' wide A wall or semi-opaque fence at least 6 feet high A continuous hedge at least 4 feet high on the interior side of the wall or fence	To accommodate proposed setbacks per Table IV Intensity and Dimensional Standards
Parking deck or Garage Standards	155.5605.c.1.d	The exposed top level of a parking structure shall be covered a minimum of 60% with a shade producing structure such as, but not limited to, a vined pergola or retractable canvas shade structure.	15% Min.	No Building shall be high enough to see top of garage.
Parking deck or Garage Standards	155.5605.c.3	If the deck or garage is accessed from a street, there shall be only one point of access to the garage area from that street.	Two (2) Points of Access	More Efficient Traffic Circulation for Residents and Commercial use respectively.

OFF-STREET PARKING REQUIREMENTS

The table below depicts parking standards for the proposed development.

Table VI		
Master Parking Plan		
Type	Required	
Dwelling, Multi-Family	1 BD	1 Space/ du
	2 BD	2 Spaces/ du
	3 BD	2 Spaces/ du
Guest parking	10% of provided parking	
Handicap Parking	As provided in Article 5-ADA: 2% of total parking	
Restaurant	1 sp/ 4 seats	
Marine Showroom	1 sp / 500 sf	
Marine Retail	1 sp/ 300 sf	
<i>(All other Uses as provided by in Table 155.5102.D.I: Minimum Number of Off-Street Parking spaces</i>		
<i>(On street parallel parking stall size: 10'x26'</i>		

P&Z



P&Z

PZ21-13000006
HIDDEN HARBOUR
1/20/22

EXHIBIT A
LOCATION MAP

P&Z

PZ21-13000006

1/26/2022

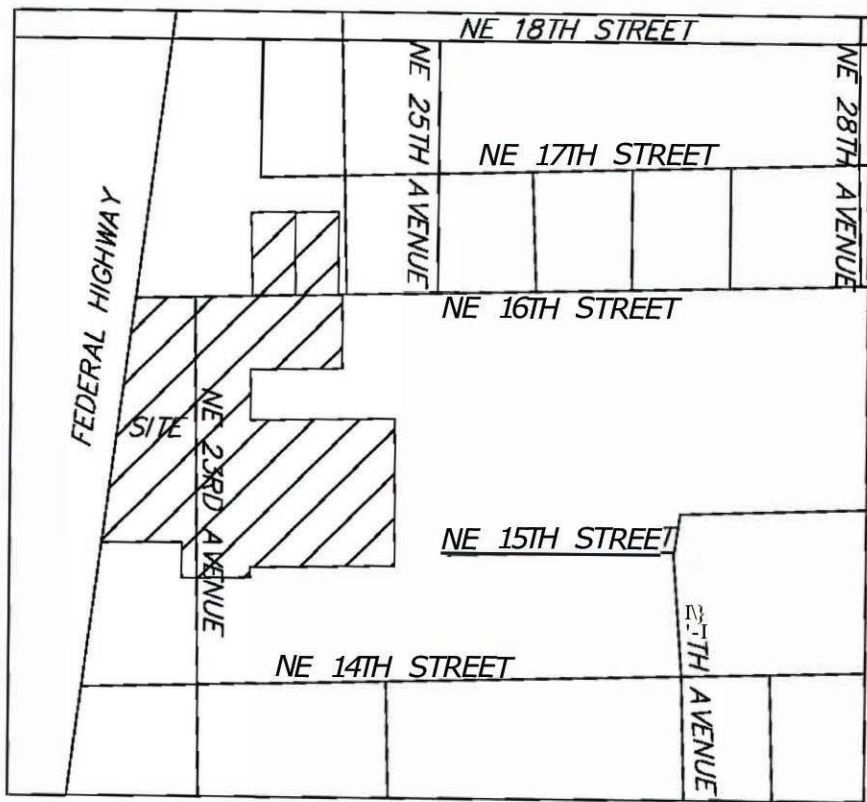

LOCATION MAP .

NTS

NORTH

P&Z

PZ21-13000006

1/26/2022



P&Z

PZ21-13000006

1/26/2022

EXHIBIT B
LEGAL DESCRIPTION

LAND DESCRIPTION – HIDDEN HARBOUR PD-I AS PROPOSED TO BE AMENDED:

(PARCEL 1-comprised of the following parcels designated as Parcels 1A-1F)

(PARCEL 1 A)

All of Parcel "A" of JERICO BOATS ENTERPRISES, according to the Plat thereof, recorded in Plat book 146, Page 3 of the Public Records of Broward County, Florida.

(PARCEL 1 B)

Lots 1 and 2, Block 2, SEA BARGE YACHT CENTER, according to the Plat thereof, recorded in Plat Book 38, Page 27 of the Public Records of Broward County, Florida. PLUS the South 1/2 of the vacated N.E. 15th Street, lying north of Lot 1, Block 2, SEA BARGE YACHT CENTER, according to the Plat thereof, recorded in Plat Book 38, Page 27 of the Public Records of Broward County, Florida.

(PARCEL 1 C)

All of Block 3, LESS the south 265.00 feet thereof, SEA BARGE YACHT CENTER, according to the Plat thereof as recorded in Plat Book 38, Page 27 of the Public Records of Broward County, Florida. Plus the south 1/2 of the vacated N.E. 15th Street, lying north of Block 3, SEA BARGE YACHT CENTER, according to the Plat thereof as recorded in Plat Book 38, Page 27 of the Public Records of Broward County, Florida.

(PARCEL 1 D)

Lots 1, 2, 6, 7 and 8, in Block 1 and all of Tracts "A", "B", "C" and "D" of SEA BARGE YACHT CENTER, according to the Plat thereof, recorded in Plat Book 38, Page 27 of the Public Records of Broward County, Florida. PLUS the north 1/2 of the vacated N.E. 15th Street, lying south of Lot 8, Block 1 of SEA BARGE YACHT CENTER, according to the Plat thereof, recorded in Plat Book 38, Page 27 of the Public Records of Broward County, Florida. PLUS the north 1/2 of the vacated N.E. 15th Street, lying south of Tract "D" of SEA BARGE YACHT CENTER, according to the Plat thereof, recorded in Plat Book 38, Page 27 of the Public Records of Broward County, Florida.

(PARCEL 1 E)

That portion of the SEA BARGE YACHT BASIN as shown on the Plat of SEA BARGE YACHT CENTER, as recorded in Plat Book 38, Page 27, of the Public Records of Broward County, Florida, described as follows:

That property lying west of the east line of the West Three Quarters (W 3/4) of the Northwest One-Quarter (NW 1/4) of the Southwest One-Quarter (SW 1/4) of Section 30, Township 48 South, Range 43 East and bounded on the south by the northerly boundary of Tract "D" of said SEA BARGE YACHT CENTER, according to the Plat thereof, recorded in Plat Book 38, Page 27 of the Public Records of Broward County, Florida, bounded on the west by the easterly boundary of Tract "C" of said SEA BARGE YACHT CENTER and bounded on the north by the southerly boundary of Tract "B" of said SEA BARGE

P&Z

PZ21-13000006

1/26/2022

YACHT CENTER. Together with that portion of said Sea Barge Yacht Basin described as follows: That portion of Lots 30 and 31 of CALIBAN, according to the Plat thereof, recorded in Plat Book 27, Page 12 of the Public Records of Broward County, Florida, as bounded on the north by the southerly boundary of Tract "B", SEA BARGE YACHT CENTER, according to the Plat thereof, recorded in Plat Book 38, Page 27 of the Public Records of Broward County, Florida, bounded on the west by the east line of the West Three-Quarters (W 3/4) of the Northwest One-Quarter (NW 1/4) of the Southwest One-Quarter (SW 1/4) of said Section 30, bounded on the east by a line 10.00 feet west of and parallel to the east line of said Tract "B" of said SEA BARGE YACHT CENTER.

(PARCEL 1 F)

Lots 3 & 4 of CALIBAN, according to the Plat thereof as recorded in Plat Book 27, at Page 12 of the Public Records of Broward County, Florida.

(PARCEL 2)

Lots 3, 4 and 5, Block 1, of SEA BARGE YACHT CENTER, according to the Plat thereof, as recorded in Plat Book 38, Page 27, of the Public Records of Broward County, Florida.

(PARCEL 3)

A portion of the Caliban Yacht Basin, CALIBAN, according to the plat thereof as recorded in Plat Book 27, Page 12, of the Public Records of Broward County, Florida lying North of and adjacent to Parcel "A", JERICHO BOATS ENTERPRISES, according to the plat thereof as recorded in Plat Book 146, Page 3, of the Public Records of Broward County, Florida and being more fully described as follows:

BEGINNING at the Northeast corner of said Parcel "A", JERICHO BOATS ENTERPRISES; thence South 88°14'47" West on the North line of said Parcel "A" and also on the South line of Caliban Yacht Basin, a distance of 327.60 feet to the Northwest corner of said Parcel "A", JERICHO BOATS ENTERPRISES; thence North 00°57'15" West, on the Northerly extension of the west line of said Parcel "A", JERICHO BOATS ENTERPRISES, a distance of 15.00 feet; thence North 88°14'47" East on a line 15.00 feet North of and parallel with the North line of said Parcel "A", JERICHO BOATS ENTERPRISES, a distance of 327.60 feet; thence South 00°57'23" East, a distance of 15.00 feet to the POINT OF BEGINNING.

Said lands situate in the City of Pompano Beach, Broward County, Florida and containing 313,525 square feet (7.1975 acres) more or less.

P&Z

PZ21-13000006

1/26/2022

P&Z

PZ21-13000006

HIDDEN HARBOUR

1/1/2022



P&Z

PZ21-13000006
1/26/2022

EXHIBIT C
CURRENT ZONING

P&Z

PZ21-13000006

HIDDEN HARBOUR

1/1/2022

EXHIBIT "C"

Current Zoning

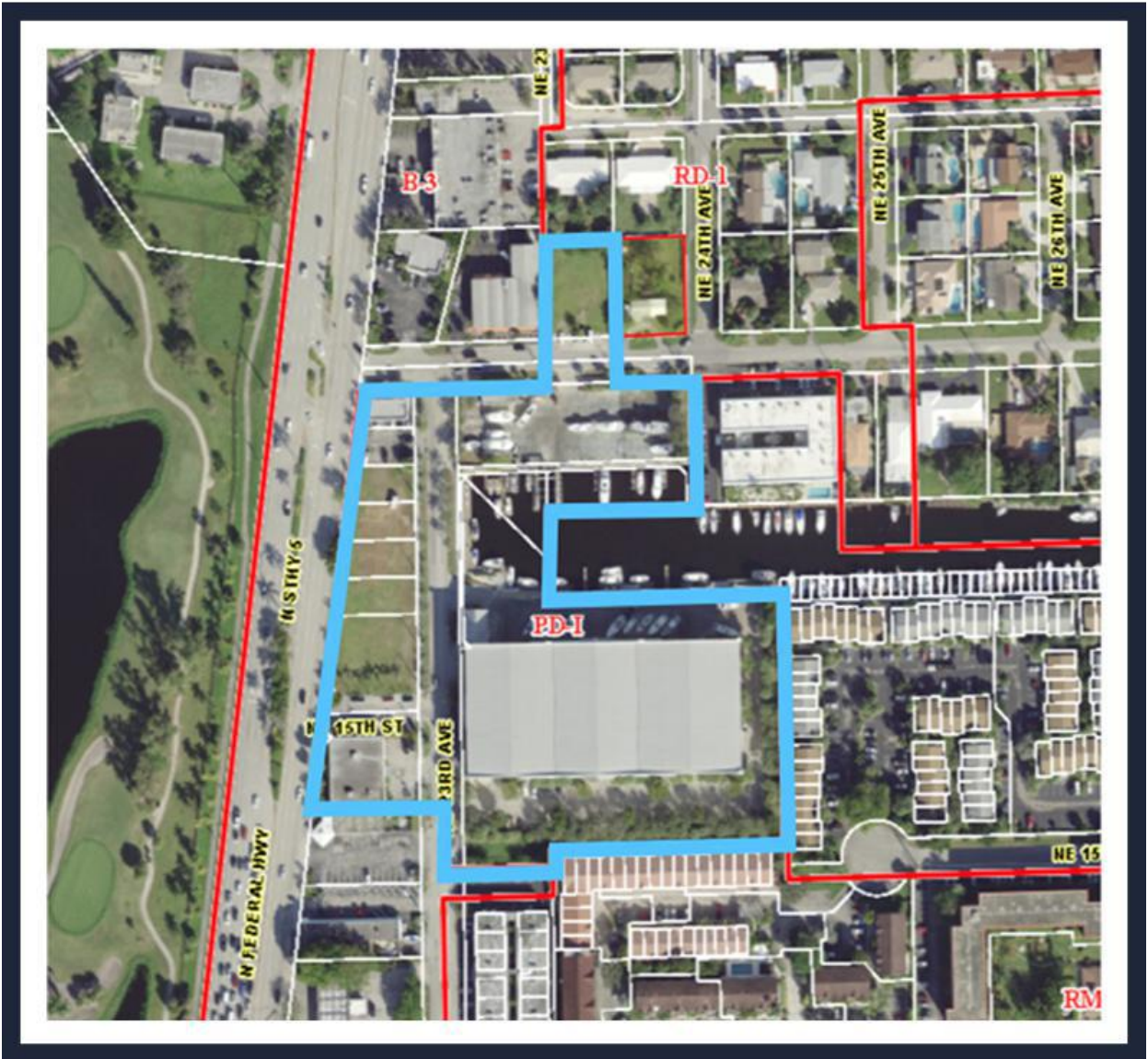

P&Z

PZ21-1300006
1/26/2022



P&Z

PZ21-13000006
HIDDEN HARBOUR
1/20/2022

EXHIBIT D
EXISTING / PROPOSED ZONING

P&Z

PZ21-13000006

HIDDEN HARBOUR

1/2022

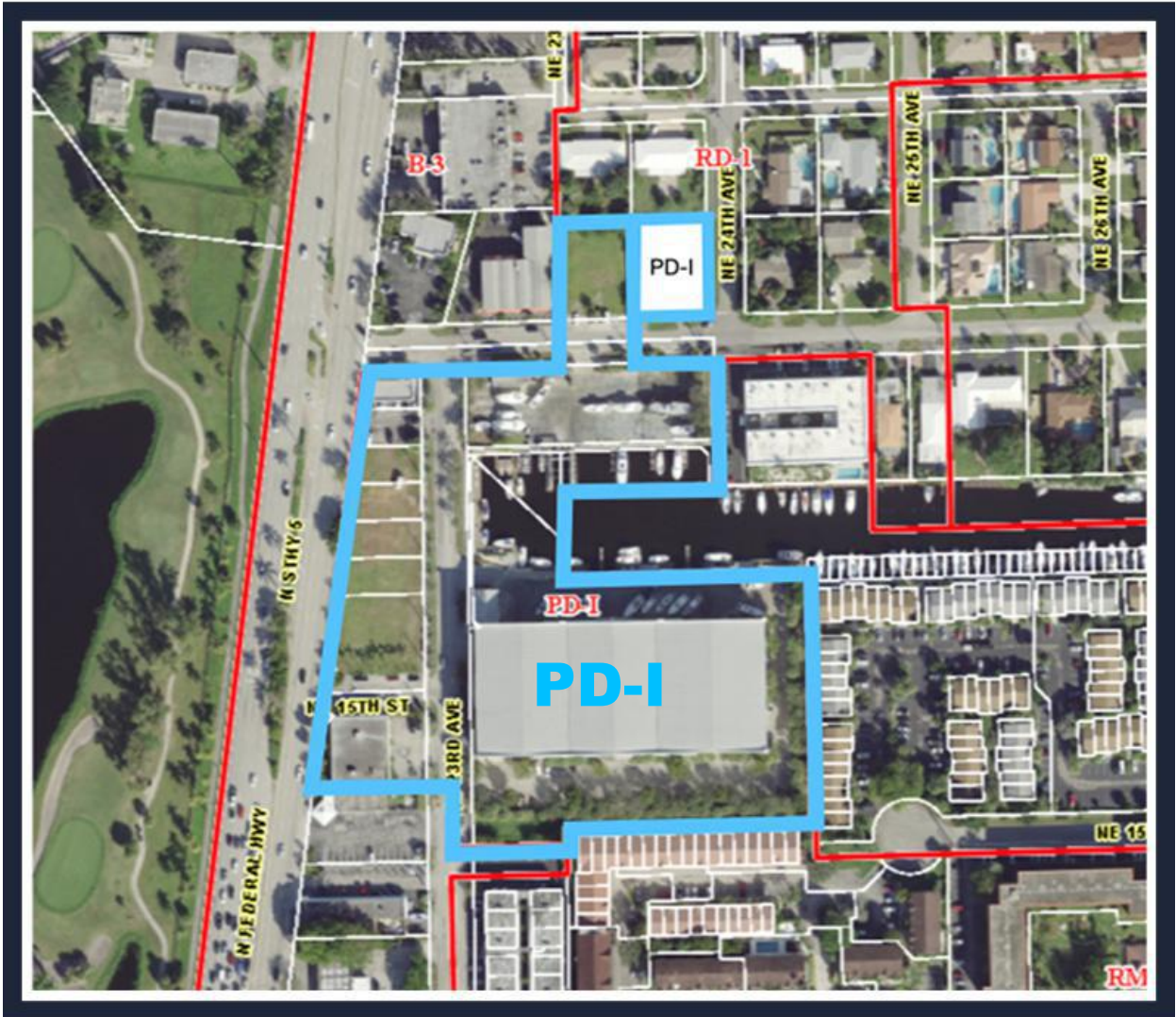
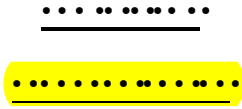

P&Z

PZ21-1300006
1/26/2022



P&Z

PZ21-13000006

1/26/2022

EXHIBIT E1

PD MASTER PLAN + MASTER PLAN DATA



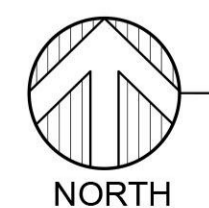

PD | MASTER PLAN

SCALE: 1" = 40'

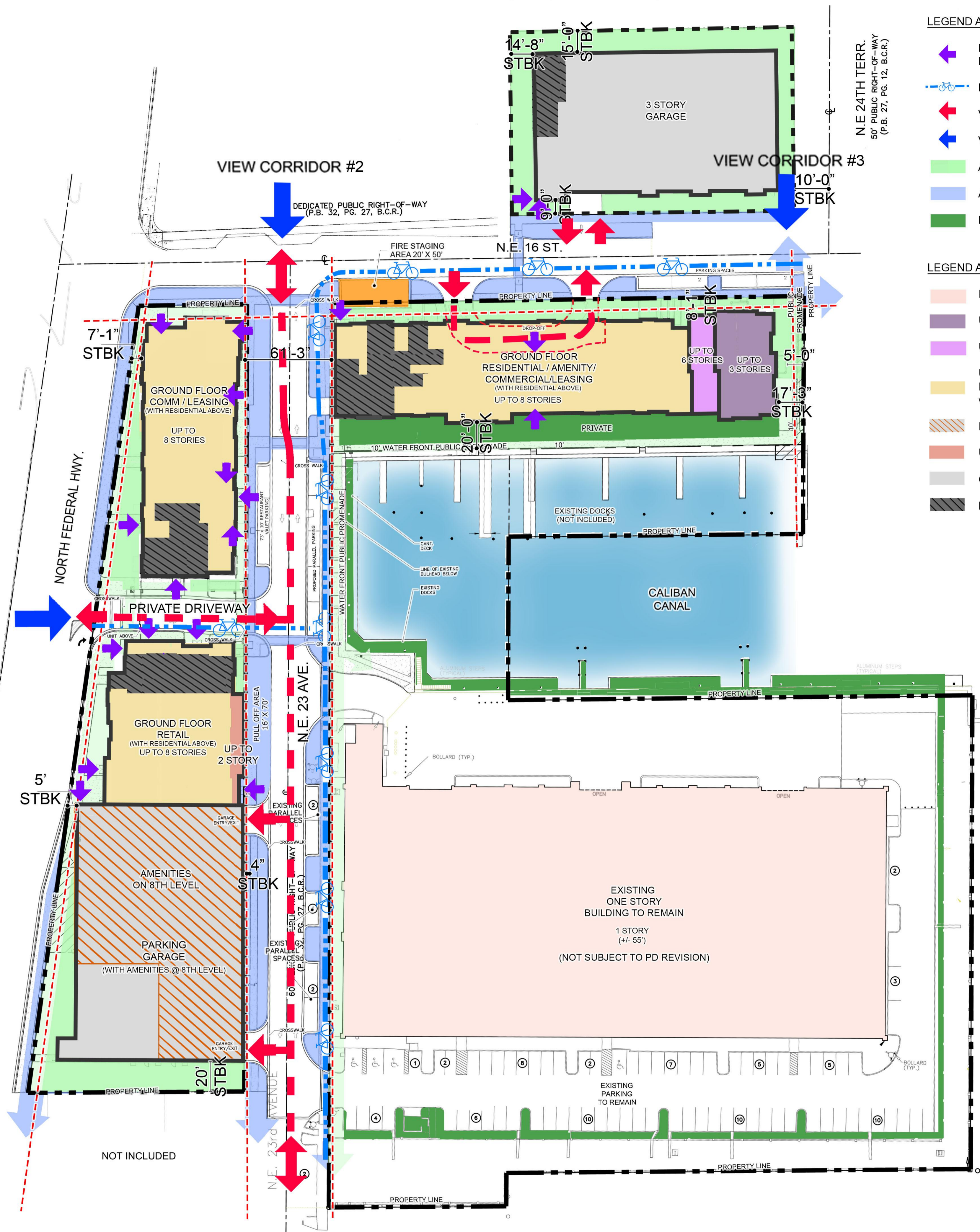

- LEGEND ACCESSES**
- POTENTIAL PEDESTRIAN ACCESS POINTS TO BUILDINGS
 - BICYCLE CIRCULATION
 - VEHICUL ACCESS TO SITE & GARAGE
 - VIEW CORRIDORS
 - ACTIVE OPEN SPACE (PRIVATE)
 - ACTIVE OPEN SPACE (PUBLIC)
 - PASSIVE OPEN SPACE (PRIVATE)
- LEGEND AREAS**
- EXISTING BUILDING (BOAT STORAGE FACILITY)
 - UP TO 3 STORIES - ALL RESIDENTIAL
 - UP TO 6 STORIES - ALL RESIDENTIAL
 - UP TO 8 STORIES - GROUND FLOOR RESIDENTIAL/ AMENITY / COMMERCIAL & RETAIL WITH RESIDENTIAL ABOVE
 - ROOFTOP AMENITIES ON 8TH LEVEL
 - UP TO 2 STORY - GROUND FLOOR RETAIL
 - GARAGE
 - BACK OF HOUSE / MEP/ SERVICE AREAS

TABLE III CONSOLIDATED USE TABLE

P = PERMITTED PRINCIPAL USE
S = USE ALLOWED AS A SPECIAL EXCEPTION
A = PERMITTED ACCESSORY USE
T = PERMITTED TEMPORARY USE

Use Category	Use Type	Permitted	Use-Specific Standards
Household Living Uses	Dwelling, live/work	P	155.4202.A
	Dwelling, multifamily	P	155.4202.C
	Dwelling, mixed-use	P	155.4202.G
Communication Uses	Telecommunications facility, collocated on existing structure other than telecommunications tower	P	155.4204.C 155.4204.D
	Child Care Facility	P/A	155.4206.B
Health Care Uses	Medical office	P	155.4209.A
	Specialty medical facility	P	155.4209.B
	Urgent care facility 24 hours	P	155.4209.C
Open Space Uses	Park or plaza	P/A	155.4210.D
Animal Care Uses	Animal grooming	P	155.4214.A
	Pet shop	P	155.4214.E
Boat and Marine Sales and Service Uses	Boat dry storage facility	P/A	155.4215.B
	Boat or marine parts sales without installation	P/A	155.4215.C
	Boat or marine parts sales with installation	P/A	155.4215.D
	Boat or marine repair and servicing	P/A	155.4215.E
	Boat sales or rental	P/A	155.4215.F
	Boat towing service	P/A	155.4215.G
	Docking facility, barge	P/A	155.4215.H
	Docking facility, commercial fishing boat	P/A	155.4215.I
	Docking facility, recreational boat	P/A	155.4215.J
	Marina	P/A	155.4215.K
Commercial or Membership Recreation/ Entertainment Uses	Yacht Club	P	155.4215.L
	Other indoor commercial or membership recreation/ entertainment use	P/A	155.4217.M
Eating and Drinking Establishments	Bar or lounge	P/A	155.4218.A
	Brewpub	P/A	155.4218.B
	Restaurant	P/A	155.4218.E
	Specialty eating or drinking establishment	P/A	155.4218.F
Office Uses	Professional office	P	155.4220.B
Retail Sales and Service Uses - Personal Services	Bank or financial institution	P	155.4221.C
	Personal services establishment	P	155.4221.K
	Book or media shop	P	155.4222.D
	Grocery or convenience store	P/A	155.4222.F
	Drug store or pharmacy	P	155.4222.G
	Farmers' market	P	155.4222.H
	Beer or wine store	P	155.4222.M
	Retail sales establishment, large	P	155.4222.P
	Other retail sales establishment	P	155.4222.R
	Visitor Accommodation Uses	Condo hotel	P
Bed and breakfast inn		P	155.4225.B
Hotel or motel		P	155.4225.C
Typical Accessory Uses and Structures	Dock	A	155.4303.H
	Drop-in child care	A	155.4303.J
	Electric vehicle (EV) level 1, 2, or 3 charging station	A	155.4303.K / 155.4303.L
	Fence or wall	A	155.4303.O
	Green roof	A	155.4303.R
	Home based business	A	155.4303.S
	Outdoor display of merchandise	A	155.4303.U
	Outdoor seating, including sidewalk cafes (as accessory to eating and drinking establishments)	A	155.4303.V
	Parking or storage of motor vehicles, recreational vehicles, boats, airboats, or trailers	A	155.4303.X
	Rainwater cistern or barrel	A	155.4303.Z
	Retail sales (as accessory uses)	A	155.4303.BB
	Small wind energy system	A	155.4303.DD
	Solar energy collection system	A	155.4303.EE
	Swimming pool or spa or hot tub	A	155.4303.GG
	Mechanical Equipment and similar features	A	155.4303.JJ
Uncovered porches, decks, patios, terraces, or walkways	A	155.4303.KK	
Lighting fixtures, projecting or freestanding	A	155.4303.MM	
Eating and drinking establishments (as an accessory use)	A	155.4303.PP	
Farmer's market (as a temporary use)	T	155.4403.A	

ARCHITECT'S BUILDING CODE STATEMENT: TO THE BEST OF THE ARCHITECT'S KNOWLEDGE THE PLANS AND SPECIFICATIONS COMPLY WITH THE FLORIDA BUILDING CODE SIXTH EDITION (2017) AND THE APPLICABLE FIRE SAFETY STANDARDS AS DETERMINED BY THE LOCAL AUTHORITY AND CHAPTER 633 FLORIDA STATUTES.

HARBORSIDE AT HIDDEN HARBOUR
FOR: AMP IV-HIDDEN HARBOUR, LLC
LOCATED AT: POMPANO BEACH, FLORIDA

BEATRIZ M. HERNANDEZ
AR0094576

MSA ARCHITECTS, INC.
AAC000895
8850 SW 74th COURT
MIAMI, FLORIDA 33156
(305) 273-9911

MSA ARCHITECTS
ARCHITECTURE & PLANNING

COPYRIGHT © 2019 MSA ARCHITECTS, INC. THE ARCHITECTURAL DESIGN AND DETAIL DRAWINGS FOR THIS BUILDING AND/OR OVERALL PROJECT ARE THE LEGAL PROPERTY OF AND ALL RIGHTS ARE RESERVED BY THE ARCHITECT. THEIR USE FOR REPRODUCTION, CONSTRUCTION, OR DISTRIBUTION IS PROHIBITED UNLESS AUTHORIZED IN WRITING BY THE ARCHITECT.

DRAWN -/-/
DATE -/-/
SCALE AS SHOWN
JOB NO. 1828
SHEET TITLE: MASTER SITE PLAN
SHEET NUMBER: EX - E1

TABLE I LAND USE PLAN LIMITS	
Area 1	Marina Use (including boat storage, boat repair, and slips): 75,000 square feet and 15 wet slips
Area 2	Private Park (Open to Public) / Parking
Area 3	Multi-Family Residential: 300 units Commercial Development (including, but not limited to, boat sales, offices, showrooms, and related uses): 510,000 square feet

TABLE II Type and Mix of Uses	
Residential	Up to 300 Units Max.
Commercial	Minimum of 65,000 square feet, including a minimum of 10,000 square feet of commercial uses vertically integrated in a mixed-use building fronting on Federal Highway
Total Floor Area	Maximum of 650,000 square feet

TABLE IV Intensity and Dimensional Standards		
i. Land area (acres)		
Gross Acres (to CL of ROW - to calc. for density)	9.96 Acres	
Gross Acres (including basin for park)	6.90 Acres	
Estimated Net Acres (upland area that excludes basin)	6.5 Acres	
ii. Type and mix of land uses*		
Multi-Family Residential	300 Units max.	
Commercial Development (including but not limited to: Boat sale, showrooms and related uses)	10,000 to 510,000 SQ.FT.	
Marine Use (including: Boat storage, boat repair and slips)	10,000 to 75,000 SQ. FT./ 15 Slips	
*Refer to table III for list of additional approved Type of Uses		
iii. Maximum number of residential units/ Unit Square Footage Size (SF)		
	300 du's max	
	min	max
1 Bedroom (multi-family)	580 SQFT	800 SF
2 Bedroom (multi-family)	850 SQFT	1175 SF
3 Bedroom (multi-family)	1,180 SQFT	1,350 SF
iv. Maximum Commercial -Nonresidential floor area* (Exclusive of Garage)		
Maximum Marina	75,000 SQ. FT., 15 Slips	
Minority/ Marina Use	Min. of 10% of total floor area	
*Min. 10,000 SQ. FT. of Commercial Use to be vertically integrated into mixed use building		
v. Minimum Lot Area	10,000 SQ. FT.	
vi. Minimum Lot Width	100 FT. FRONTAGE	
vii. Minimum Pervious (Calc. based on Net Acres)	20% (1.27 Acres)	
viii. Maximum Impervious area (Calc. based on Net Acres)	80% (5.23 Acres)	
ix.. Max. Building height	100 ft to 150 ft. Not to Exceed Airport Air Space Max. Height (See Exhibit K)	
x. Max. Individual building size		
Fronting Federal Highway (West of NE 23 rd Ave)	8 Stories Not to Exceed Airport Air Space Max. Height Limits (See Exhibit K)	
Fronting NE 16 th ST (East of NE 23 rd Ave)	3 Stories (35'-0") within first 50'-0" and no less than 10' of east property line / Adjacent to residential.	
	6 Stories no less than 50'-0" of East Property Line / Adjacent to residential.	
	8 Stories no less than 75'-0" of East Property Line / Adjacent to residential.	
Fronting NE 23 rd Ave (South of Caliban Canal)	Existing 1 Story Dry Boat Storage Facility to remain	

TABLE IV Intensity and Dimensional Standards			
ix. Setbacks	Min.	Max.	
North – Along North Property Lines			
Along NE 16th St.	7'-0"	63'-0"	
To 3 Story Garage	10'-0"	20'-0"	
East– Along East Property Lines			
To existing Dry Boat Storage facility	59'-0"	61'-0"	
Up to 3 Stories Residential	10'-0"	15'-0"	
Up to 6 Stories Residential	50'-0"	None	
Up to 8 Stories Residential	75'-0"	None	
Along 24th Terr to 3 Story Garage	10'-0"	20'-0"	
West– Along West Property Lines			
Along Federal Highway			
To 3 story Garage	5'-0"	30'-0"	
To 3 story Garage	10'-0"	20'-0"	
South Along South Property Lines			
To existing Dry Boat Storage Facility	91'-0"	95'-0"	
To 8 story Parking Garage	20'-0"	20'-0"	
Residential building to Face of bulkhead nose (Caliban Canal)	20'-0"	31'-0"	
Face of bulkhead nose to Property line	20'-0"	57'-0"	
To 3 story Garage	5'-0"	20'-0"	
East & West of N.E. 23Rd Ave	0'-0"	10'-0"	
Note: All Buildings' porches, stoops and balconies can project up to 7'-0" into setback or up to ROW Line whichever is less			
Additional Development Standards			
Access and Circulation	As provided in Article 5: Development Standards as provided in Deviations/ Modifications Table V		
Off-Street parking & loading	As provided in Master Parking Table VI		
Landscaping	As provided in Article 5: Development Standards as provided in Deviations/ Modifications Table V		
Tree Preservation			
Screening			
Fences and Walls			
Exterior Lighting			
Commercial and mixed-use design	As provided in Article 5: Development Standards		
Sustainable Design	As provided in Section II.A.10 of PD-I Application		
Signage	As provided in Chapter 156. Sign Code		

Table VI Master Parking Plan			
Type	Required		
Dwelling, Multi-Family	1 BD	1 Space/ du	
	2 BD	2 Spaces/ du	
	3 BD	2 Spaces/ du	
Guest parking	10% of provided parking		
Handicap Parking	As provided in Article 5-ADA: 2% of total parking		
Restaurant	1 sp/ 4 seats		
Marine Showroom	1 sp / 500 sf		
Marine Retail	1 sp/ 300 sf		
<i>All other Uses as provided by in Table 155.5102.D.I. Minimum Number of Off-Street Parking spaces</i>			
<i>On street parallel parking stall size: 10'x26'</i>			

TABLE V Deviations/ Modifications				
Type	Code Section	Description	Modification	Justification
Building Base Planting Standards	155.5203.e.3.a	Required shrubs shall be planted within three feet of the base of the building. If a street sidewalk is located between the base of the building and the street, required shrubs may be planted up to 15 feet from the base of the building.	Except where conflict with pedestrian sidewalks exist.	To accommodate Sidewalks abutting building.
Access, circulation, parking & loading Driving Aisle	155.5102.1.1	Required Aisle Width Dimensions 23'	22 FT.	To accommodate proposed site design and more efficient traffic circulation in garage.
Vehicle stacking	155.5101.G.8.B	Parking lot Entrance driveways	Min. 30 FT. stacking distance for 500 or more off-street spaces (as measured from ROW line)	To accommodate proposed site design for vehicular access.
Dwelling, Multi-Family Parking	155.5102.D.I	For Units on 2 nd floor or higher of a building with non-residential use located on ground level: 1 space per Dwelling Unit (du)	None	Due to Urban Mixed-Use Settings parking demand shall be less.
		1-2 BD 1.5 Space	1 BD 1 Space	
		All other MF 3 BD 2 Spaces	2-3 BD 2 Spaces	Guest: 10% of Provided Parking
Landscape between Vehicular Use Areas and Buildings	155.5203.D.5.A	Minimum landscaped area shall be eight feet for each story in the abutting building façade, up to 24 feet	Except where conflict with pedestrian sidewalks exist.	To accommodate Sidewalks abutting building.
Required Buffer Types and Standards	155.5203.F3	Option 1: At Least 10' wide A wall or semi-opaque fence at least 6 feet high 1 Tree per 30 linear feet + a continuous hedge at least 4 feet high on the exterior side of the wall or fence 1 shrub per 10 linear feet on the interior side of the wall or fence	Option 1: At Least 10' wide A wall or semi-opaque fence at least 6 feet high A continuous hedge at least 4 feet high on the interior side of the wall or fence	To accommodate proposed setbacks per Table IV Intensity and Dimensional Standards
Parking deck or Garage Standards	155.5605.c.1.d	The exposed top level of a parking structure shall be covered a minimum of 60% with a shade producing structure such as, but not limited to, a vined pergola or retractable canvas shade structure.	15% Min.	No Building shall be high enough to see top of garage.
Parking deck or Garage Standards	155.5605.c.3	If the deck or garage is accessed from a street, there shall be only one point of access to the garage area from that street.	Two (2) Points of Access	More Efficient Traffic Circulation for Residents and Commercial use respectively.

ARCHITECT'S BUILDING CODE STATEMENT/ TO THE BEST OF THE ARCHITECT'S KNOWLEDGE THE PLANS AND SPECIFICATIONS COMPLY WITH THE FLORIDA BUILDING CODE SIXTH EDITION (2017) AND THE APPLICABLE FIRE SAFETY STANDARDS AS DETERMINED BY THE LOCAL AUTHORITY AND CHAPTER 633 FLORIDA STATUTES.

HARBORSIDE AT
HIDDEN HARBOUR
FOR:
AMP IV-HIDDEN HARBOUR, LLC
LOCATED AT:
POMPANO BEACH, FLORIDA

BEATRIZ M. HERNANDEZ
AR0094576

MSA ARCHITECTS, INC.
AAC000895
8950 SW 74th COURT
MIAMI, FLORIDA 33156
(305) 273-9911

MSA ARCHITECTS
ARCHITECTURE & PLANNING

COPYRIGHT © 2019 MSA ARCHITECTS, INC. THE ARCHITECTURAL DESIGN AND DETAIL DRAWINGS FOR THIS BUILDING AND/OR OVERALL PROJECT ARE THE LEGAL PROPERTY OF AND ALL RIGHTS ARE RESERVED BY THE ARCHITECT. THEIR USE FOR REPRODUCTION, CONSTRUCTION, OR DISTRIBUTION IS PROHIBITED UNLESS AUTHORIZED IN WRITING BY THE ARCHITECT.

DRAWN	-/-/-
DATE	-/-/-
SCALE	AS SHOWN
JOB NO.	1828
SHEET TITLE:	MASTER SITE PLAN
SHEET NUMBER:	EX-E2

PD I MASTER PLAN

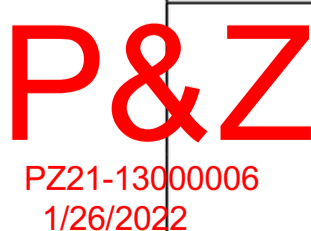

PZ21-13000006
1/26/2022



P&Z

PZ21-13000006
HIDDEN HARBOUR
1/20/2022

EXHIBIT E2
SHADOW STUDIES

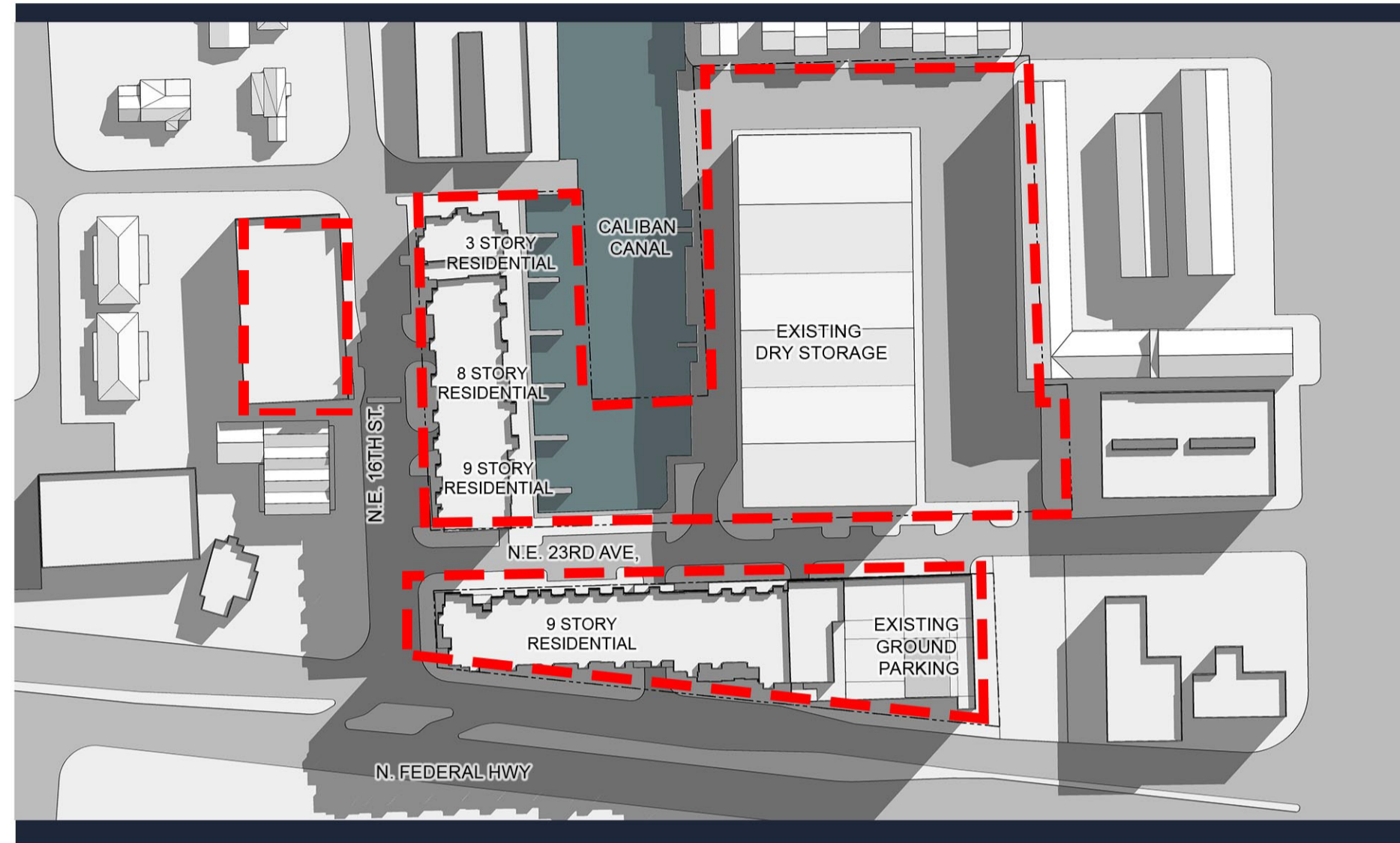

TWO HRS. BEFORE SUNSET



NORTH

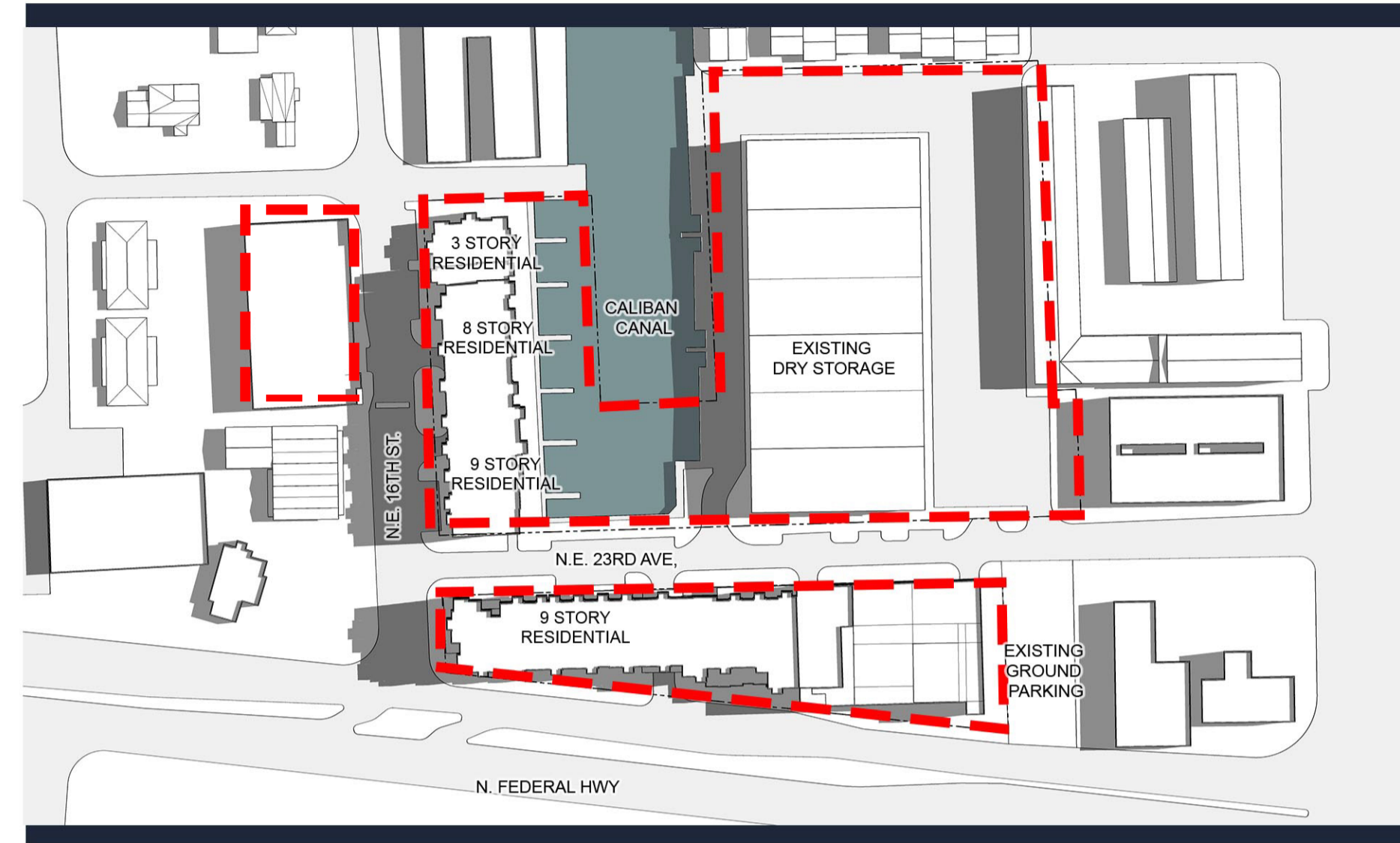

NOON



NORTH

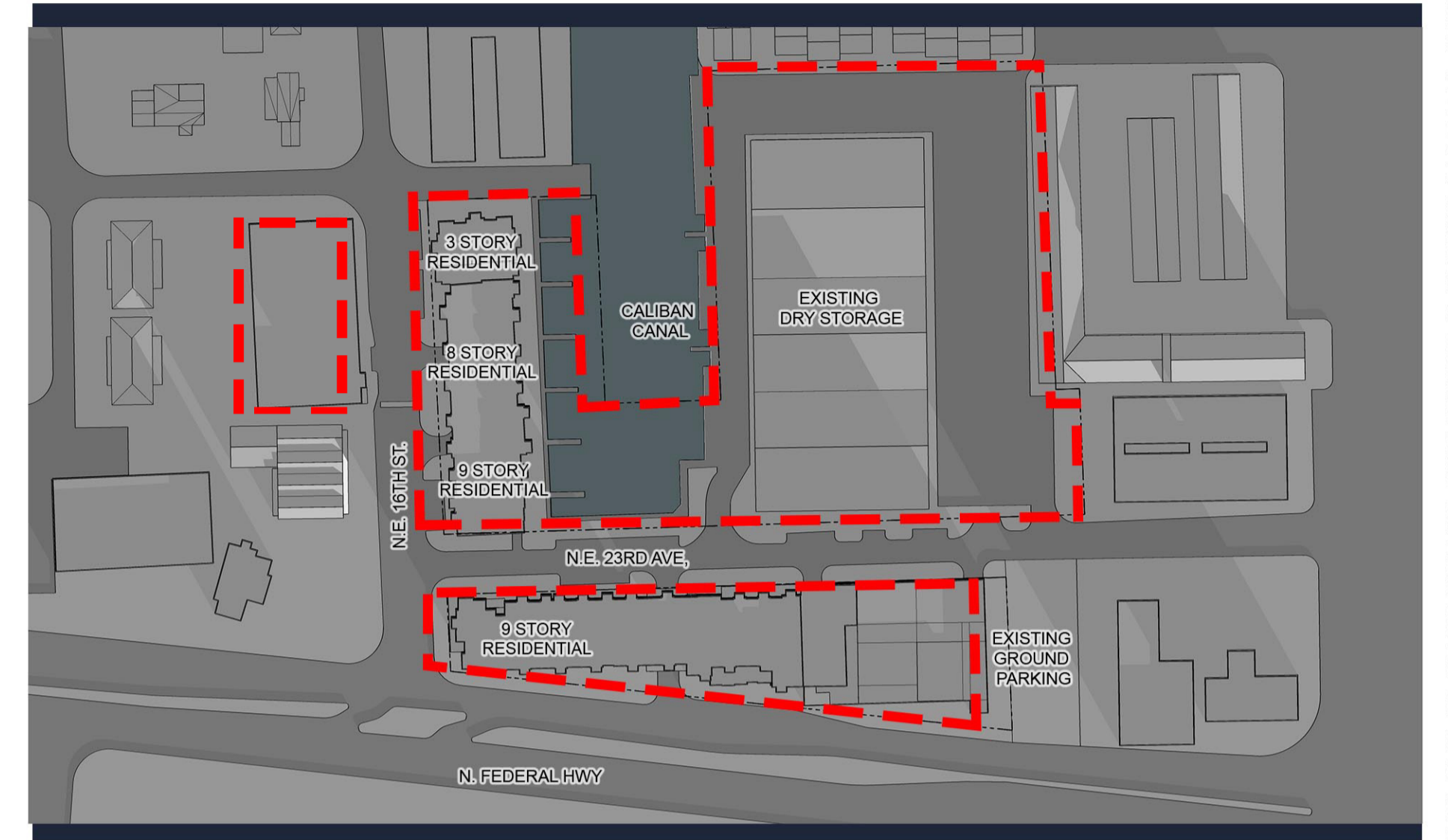

TWO HRS AFTER SUNRISE



NORTH

WINTER SOLSTICE

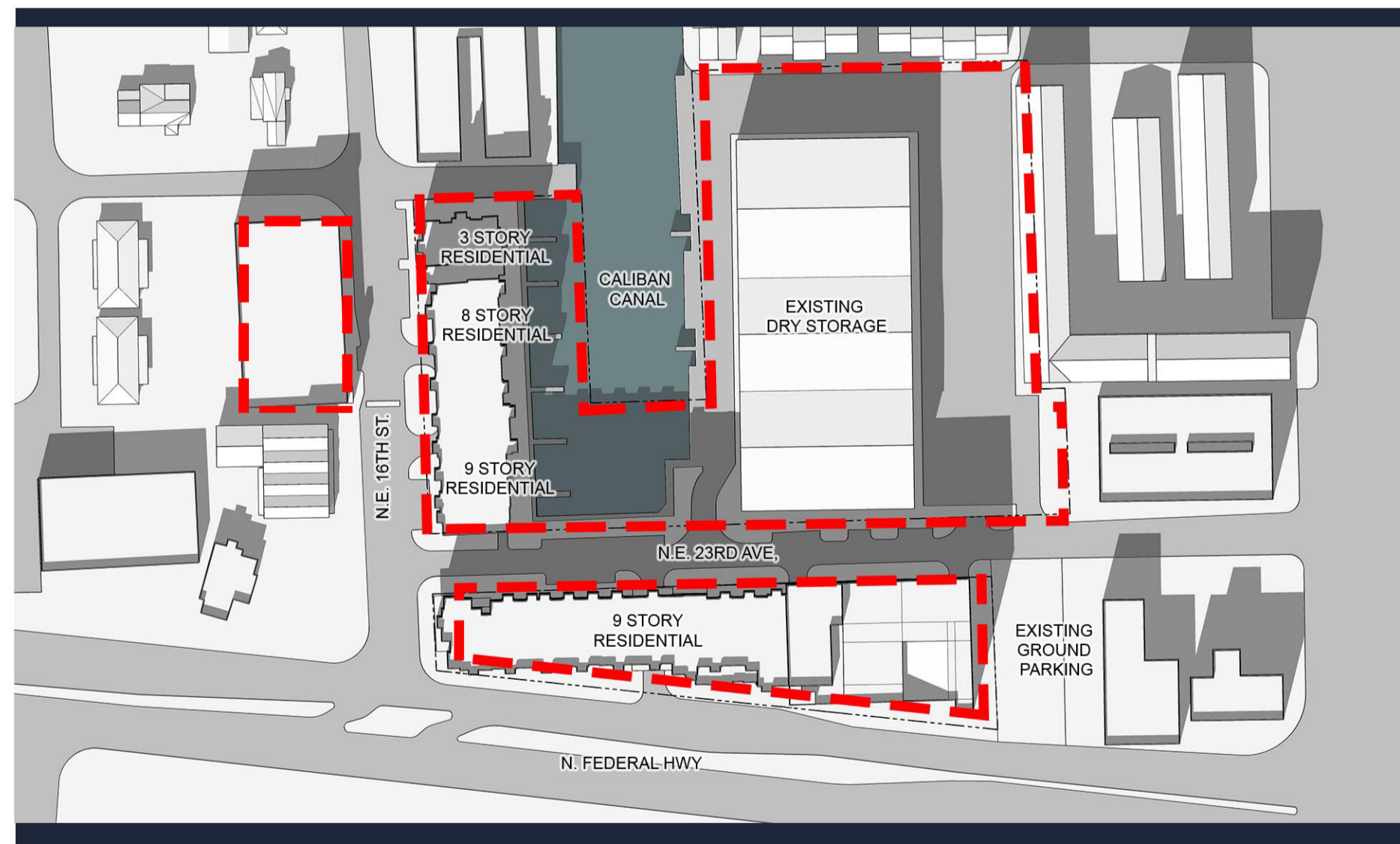

TWO HRS. BEFORE SUNSET



NORTH

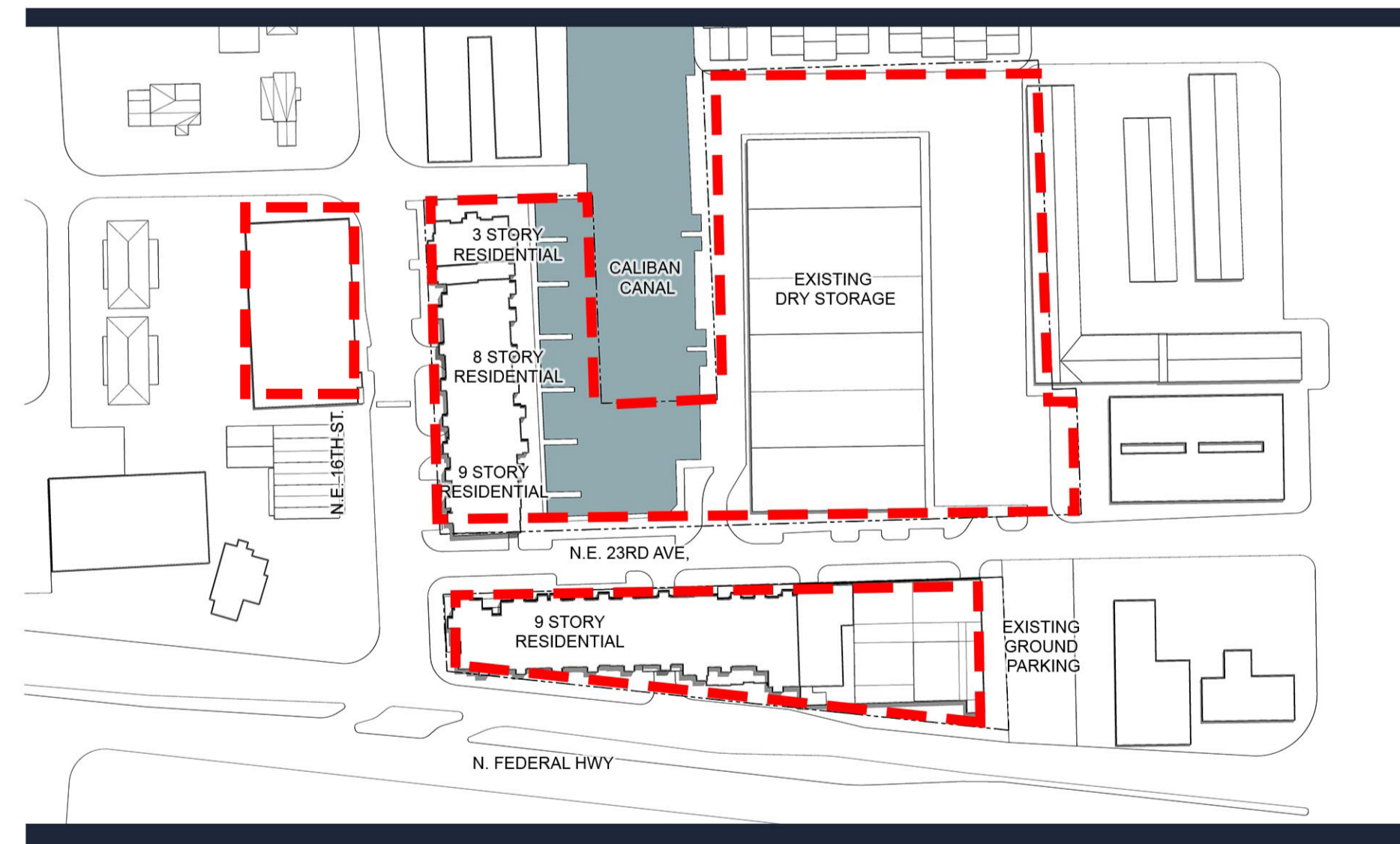

NOON



NORTH

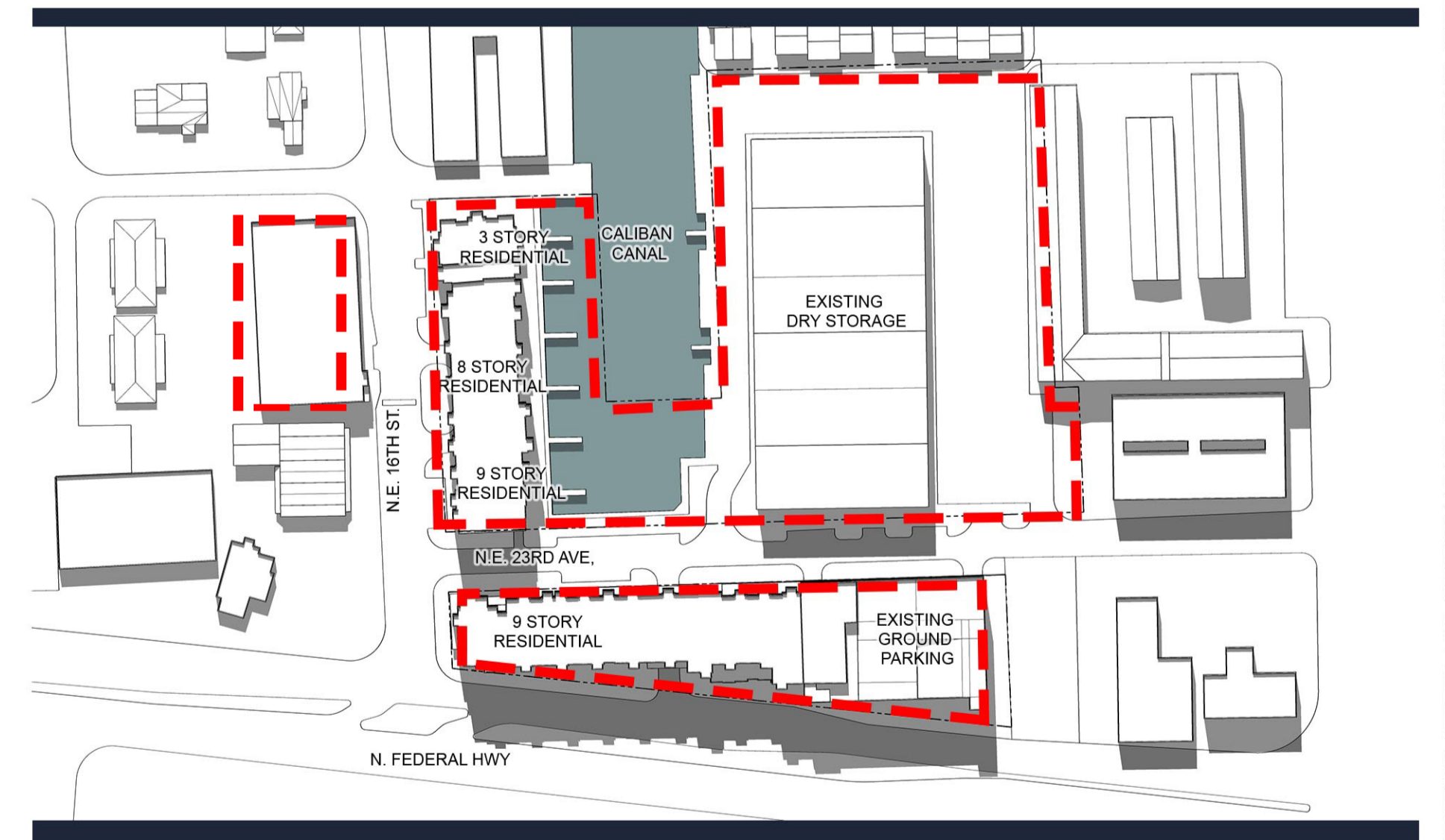

TWO HRS AFTER SUNRISE



NORTH

P&Z SUMMER SOLSTICE

PZ21-1300006
1/26/2022

HIDDEN
HARBOR

FOR: —
LOCATED AT:
POMPANO BEACH, FLORIDA

MSA ARCHITECTS, INC.

AAC000895
8950 SW 74th COURT
SUITE 1513
MIAMI, FLORIDA 33156
(305) 273-9911

MSA ARCHITECTS
ARCHITECTURE & PLANNING

ARCHITECT'S BUILDING CODE STATEMENT: TO THE BEST OF THE ARCHITECT'S KNOWLEDGE, THE PLANS AND SPECIFICATIONS COMPLY WITH THE FLORIDA BUILDING CODE SIXTH EDITION (2017) AND THE APPLICABLE FIRE SAFETY STANDARDS AS DETERMINED BY THE LOCAL AUTHORITY AND CHAPTER 633 FLORIDA STATUTES.

DRAWN: —
DATE: —/—/—
SCALE: AS SHOWN
JOB NO.: 1828

SHEET TITLE:
SHADOW STUDY

SHEET NUMBER:
EX - E3.2

BY



P&Z

PZ21-13000006
HIDDEN HARBOUR
1/20/2022

EXHIBIT E3
UTILITIES MASTER PLAN

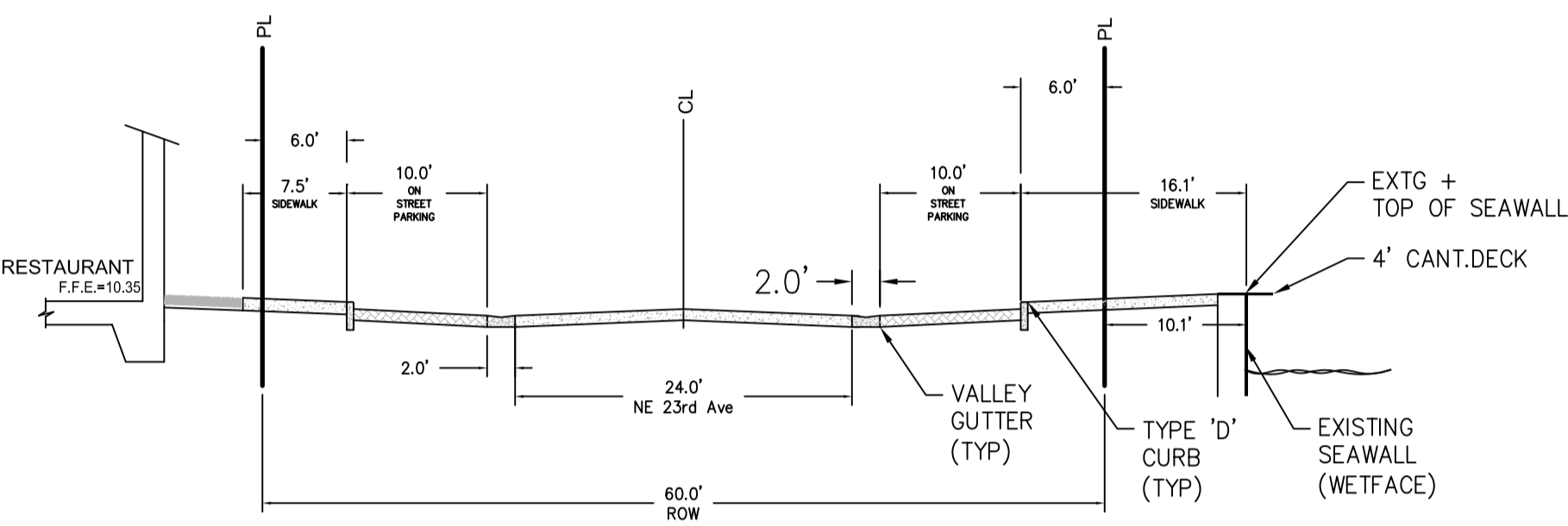
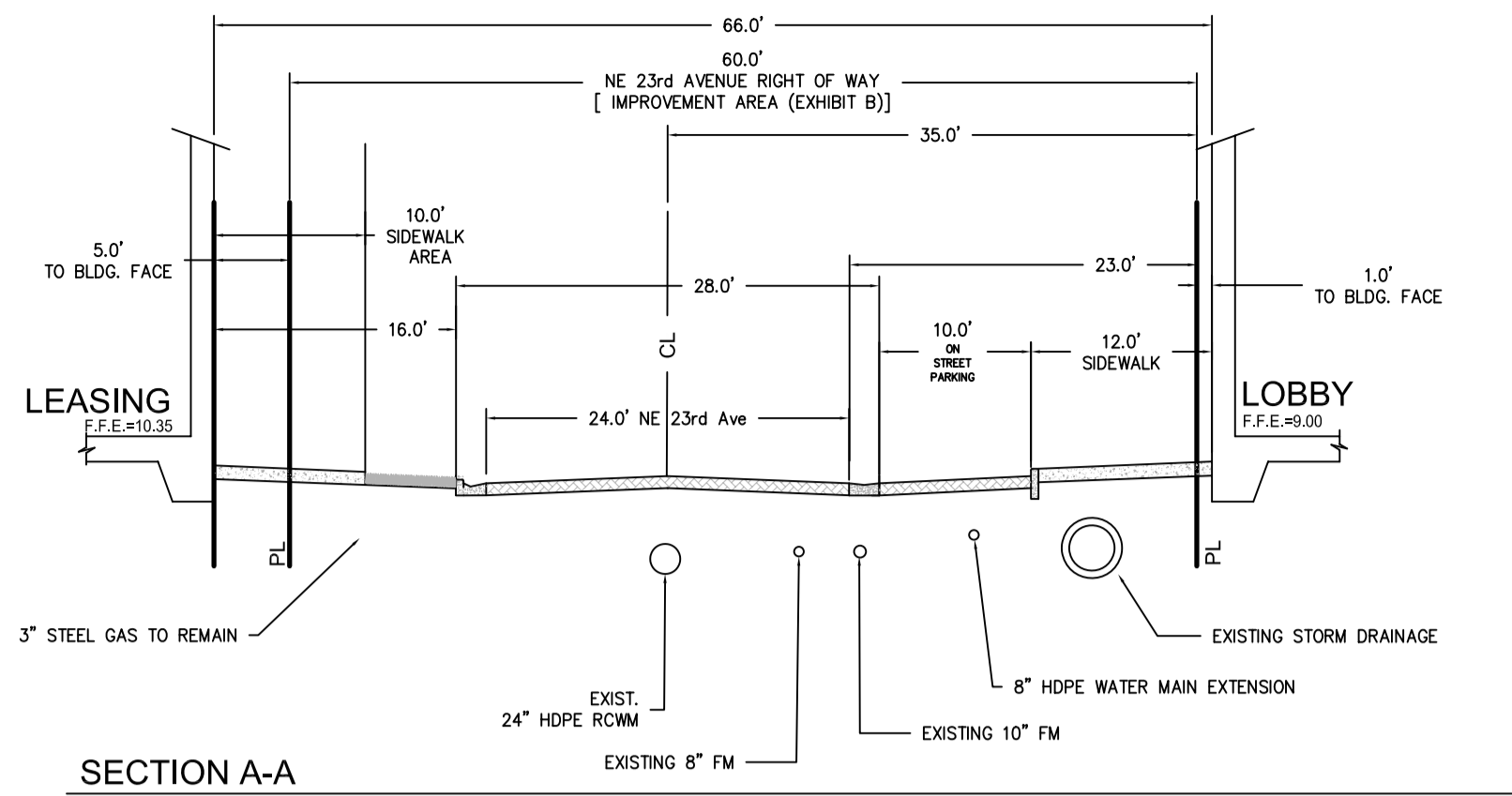

GRADING AND DRAINAGE NOTES:

1. ALL STORM DRAINAGE LINE FROM THE BLDG SHALL BE LAID @ 1.0% MINIMUM SLOPE UNLESS NOTED OTHERWISE ON PLANS.
2. CLEANOUTS ON STORM DRAINAGE LINES ARE TO BE ADJUSTED TO BE FLUSH W/ FINISHED GRADE.
3. CONTRACTOR SHALL PROVIDE FITTINGS (WYES, TEES, REDUCERS, ETC.) AS REQUIRED TO FURNISH A COMPLETE WORKING SYSTEM BASED ON THE LAYOUT SHOWN ON THESE PLANS.
4. LANDSCAPED AREAS SHALL BE GRADED TO DRAIN TO THE CATCH BASIN INLETS. FIELD ADJUST GRADING AS REQUIRED.
5. SITE UTILITY CONTRACTOR SHALL COORDINATE WITH THE BUILDING PLUMBING CONTRACTOR FOR EXACT LOCATION OF CONNECTION POINTS BETWEEN THE BUILDING AND SITE WATER, SEWER AND DRAINAGE LINES (VERTICALLY AND HORIZONTALLY).
6. RECTANGULAR CATCH BASIN AND YARD DRAIN GRATES SHALL BE INSTALLED SUCH THAT THE LONG AXIS OF GRATE PARALLELS THE CLOSEST ADJACENT WALK, BLDG. DRIVE WAY, PROPERTY LINE, OR ROADWAY.
7. COORDINATE LOCATION IN FIELD OF ALL CATCH BASINS & YARD DRAINS WITH LANDSCAPE CONTRACTOR TO AVOID CONFLICTS.
8. CENTERLINE OF YARD DRAINS @ BASE OF DOWN SPOUTS MUST ALIGN WITH CENTERLINE OF DOWN SPOUT PRIOR TO FINAL ACCEPTANCE BY OWNER. REFERENCE ARCH. PLANS FOR EXACT LOCATION OF DOWN SPOUTS.

STRUCTURE CATEGORY II, MINIMUM FFE = BFE+1
 FLOOD ZONE "X" ELEV N/A NAVD ON FIRM MAP #12011C0188H, DATE AUGUST 18, 2014
 BROWARD COUNTY 100 YEAR
 3 DAY CONTOUR = ELEV. 5.50 NAVD
 AVERAGE WET SEASON
 WATER LEVEL = ELEV. 1.50 NAVD

LEGEND:

- (0.00) PROPOSED ELEVATION (NAVD)
- (1.50) EXISTING ELEVATION (NAVD)
- ▭ PROPOSED CATCH BASIN
- ▭ PROPOSED PLUG
- ⊥ TEE
- ⊥ WATER METER
- ⊥ DOUBLE DETECTOR CHECK W/ WAFER CHECK VALVE ON DOWNSTREAM SIDE
- ⊥ REDUCED PRESSURE BACKFLOW PREVENTOR
- ⊥ DIRECTIONAL FLOW ARROW AND GRAVITY SEWER
- PROPOSED MANHOLE
- W - WATER MAIN
- FM - SANITARY FORCE MAIN
- ⊥ VALVE
- ⊥ FIRE HYDRANT
- ⊥ SIAMISE CONNECTION
- ⊥ CLEANOUT
- ▭ EDGE OF PROPOSED PAVEMENT (ASPHALT)
- DIRECTION OF SURFACE DRAINAGE
- SAMPLE POINT
- - - - EXIST. WATER MAIN
- - - - EXIST. UTILITY LINE TO BE REMOVED

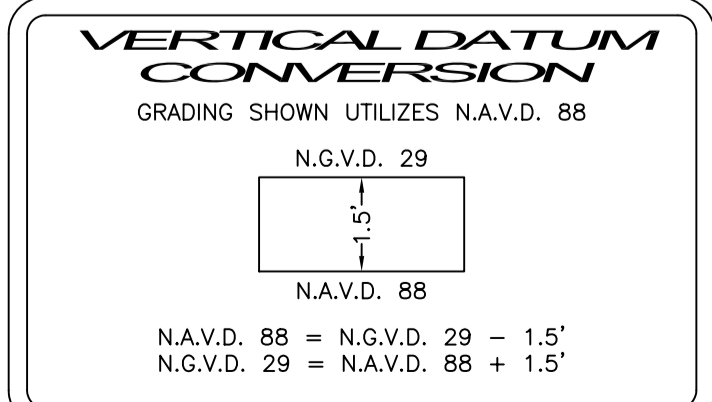
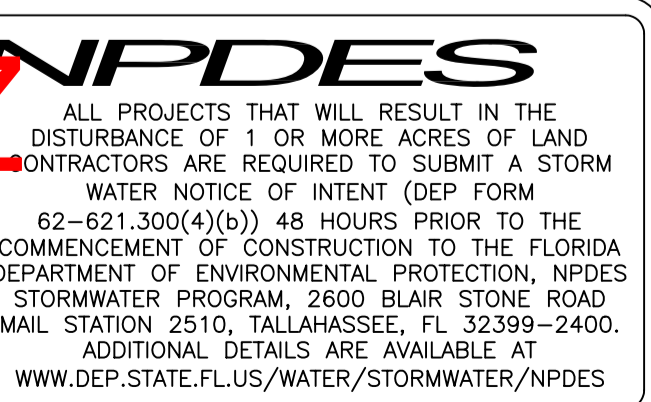
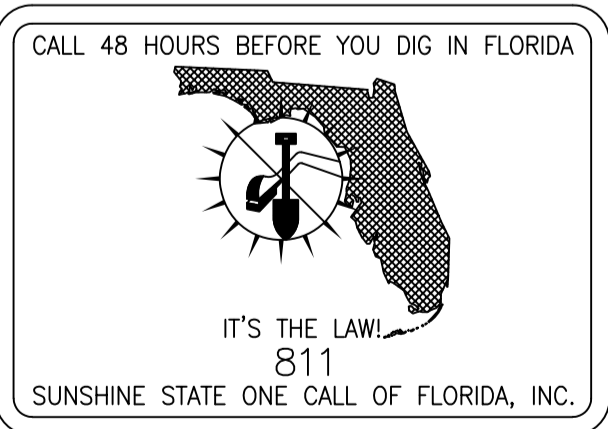

REFER TO LANDSCAPE PLANS FOR LIMITS AND DETAILS OF SILVA CELL

THE EXISTING ROADWAY WITHIN THE PROJECT LIMITS AND POSSIBLY BEYOND WILL BE INSPECTED BY THE CITY ENGINEER, PUBLIC WORKS DIRECTOR OR A DESIGNATED REPRESENTATIVE FOR DAMAGE DUE TO CONSTRUCTION PRIOR TO FINAL ACCEPTANCE. A PARTIAL OR FULL MILLING AND OVERLAY OF THE ROADWAYS MAY BE REQUIRED.

FEDERAL HIGHWAY
 (U.S. HIGHWAY 1 - STATE ROAD NO. 5)
 120' DEDICATED PUBLIC RIGHT-OF-WAY
 (P.B. 32, PG. 27, B.C.R.)

N.E. 16th STREET
 60' DEDICATED PUBLIC RIGHT-OF-WAY
 (P.B. 32, PG. 27, B.C.R.)

N.E. 23rd AVENUE
 60' DEDICATED PUBLIC RIGHT-OF-WAY
 (P.B. 32, PG. 27, B.C.R.)

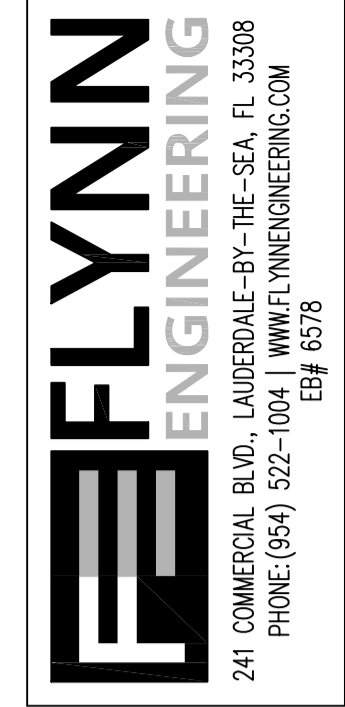
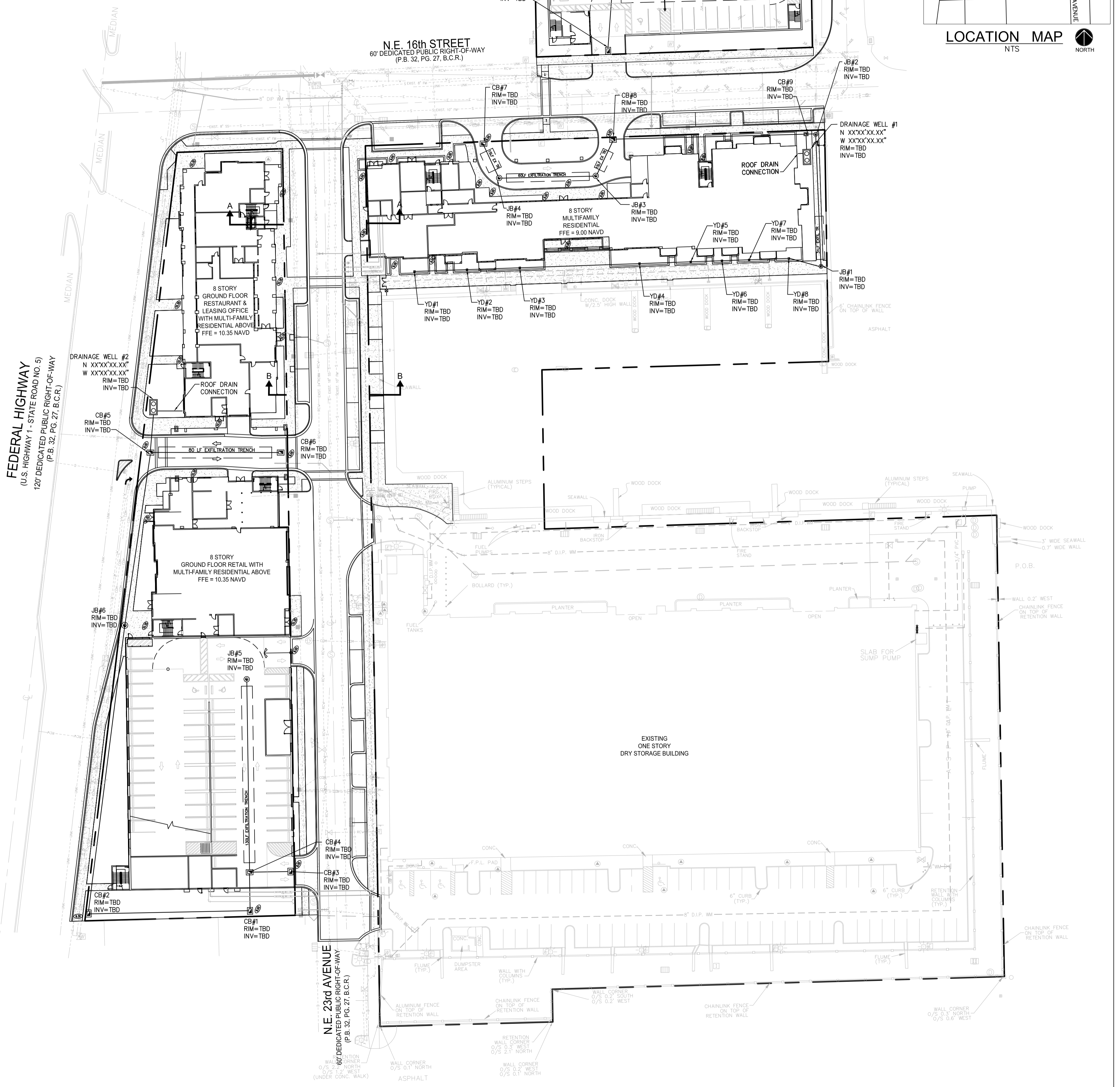
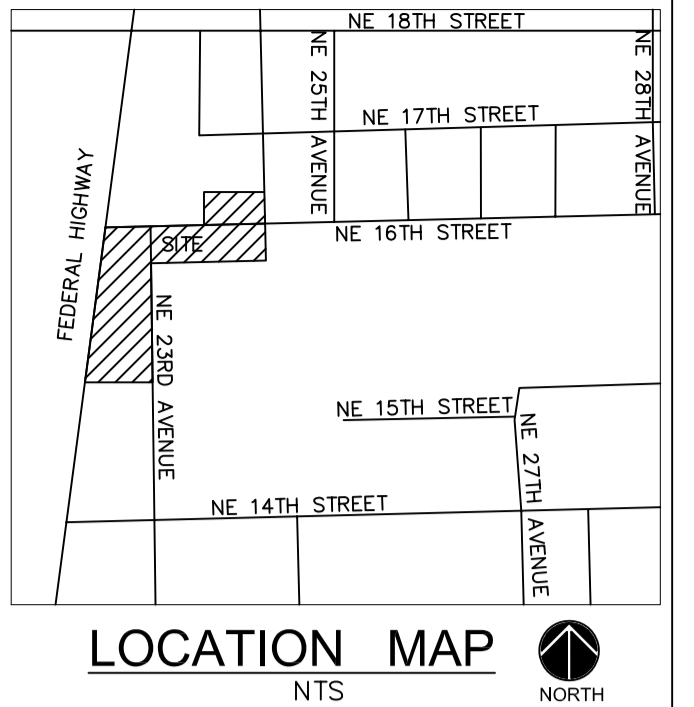

Sheet Title
CONCEPTUAL PAVING, GRADING & DRAINAGE PLAN

Job Title
HIDDEN HARBOUR
 POMPANO BEACH, FLORIDA 33062

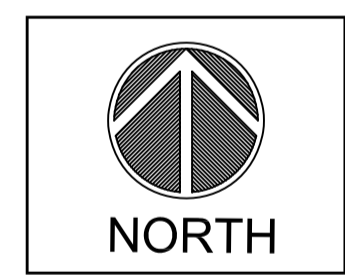

Revisions

Phase:
 DRC
 DOCUMENTS

SEAL

Scale:	1"=40'	Date:	09/28/21
Job No.:	05-0606.07	Pld Date:	09/28/21
Drawn by:	SHG	Sheet No.:	C1
Proj. Mgr.:	SHG	Appr. by:	SHG
		1 of 3	



P&Z

PZ21-13000006
HIDDEN HARBOUR
1/20/2022

EXHIBIT F
WATER & SEWER AVAILABILITY LETTERS

September 20, 2021

Mr. Shane Grabski, P.E.
Project Engineer
Flynn Engineering Services P.A.
241 Commercial Blvd.
Lauderdale-By-The-Sea, FL 33308

RE: Hidden Harbor – Water, Wastewater and Reuse Water Capacity Availability

Location: 1500 N. Federal Highway, Pompano Beach, FL 33062

FES #: 05-0606.05

Dear Mr. Grabski:

We are the provider of potable water services, wastewater collection system and reuse services for the subject site in the City of Pompano Beach.

Estimations by your office regarding the projection of future water, wastewater and reuse water increased demand were reviewed by our office. Our utility can accommodate the increase in demand presented in the subject estimates.

There are no known objections to the proposed development for obtaining potable water services, wastewater collection services or reuse services other than payment of hook-up or installation fees, line extensions to be paid for by the applicant in connection with the construction of the development or other such routine administrative procedure.

A study by the developer through the City of Pompano Beach may need to be conducted to assess impacts of new wastewater flows and water demands on the existing infrastructure.

Please note that this determination does not constitute an allocation or reservation of capacity in existing infrastructure including transmission lines, distribution lines, or treatment facilities.

Sincerely,

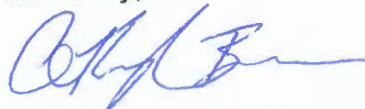

A. Randolph Brown,
Utilities Director



Luigi Pace
GOVERNMENT AFFAIRS
Lpace@wm.com
WASTE MANAGEMENT
2380 COLLEGE AVENUE
DAVIE, FL 33317
954.991.5089
954.634.6005 FAX

April 19, 2019

Mr. Damon Ricks
Flynn Engineering Services, P.A.
241 Commercial Blvd.
Lauderdale By The Sea, FL 33308

RE: Hidden Harbour

Dear Mr. Ricks,

I have reviewed the updated information you sent me regarding the land use amendment for the proposed project in Pompano Beach located at 1500 N Federal Hwy. Per your letter, I wanted to inform you that Waste Management's local disposal facilities have the adequate volume space to safely accommodate the anticipated waste generated by the proposed project. In addition, Waste Management's collections operations have sufficient equipment available to provide the required services to this project during all the developmental phases from construction to final occupation by residents and tenants.

Waste Management is the authorized municipal hauler for the City of Pompano Beach, please contact us as soon as you are ready to begin construction at this site so that Waste Management can provide the containers that you will need during this project.

If you should have any additional, questions please do not hesitate in giving me a call.

Thank you,

A handwritten signature in black ink, appearing to read "Luigi Pace". The signature is written in a cursive style with a large, sweeping flourish that extends to the right and loops back under the name.

Luigi Pace
Government Affairs Manager

P&Z

PZ21-13000006

1/26/2022



P&Z

PZ21-13000006
HIDDEN HARBOUR
1/20/2022

EXHIBIT G
DECLARATION OF RESTRICTIONS

This instrument was prepared by:

Name: Graham Penn, Esq.
Address: Bercow Radell Fernandez & Larkin, PLLC
200 S. Biscayne Boulevard, Suite 850
Miami, FL 33131

(Space reserved for Clerk)

DECLARATION OF RESTRICTIONS

WHEREAS, the undersigned Owner holds the fee simple title to an assemblage of land in Pompano Beach, Florida, described in Exhibit "A," attached hereto, and hereinafter called the "Property," which is supported by the submitted attorney's opinion, and

WHEREAS, the Property is the Amendment Site of Pompano Beach Land Use Plan Map Amendment Application 15-91000001; and

WHEREAS, the Owner has sought to change the designation of the Amendment Site from "Commercial," "Low-Medium (10) Density Residential," and "Medium-High Density Residential" to "Mixed-Use High."

NOW THEREFORE, in order to assure the City of Pompano Beach (the "City") that the representations made by the Owner during the consideration of the Application will be abided by the Owner, its successors and assigns, freely, voluntarily, and without duress, makes the following Declaration of Restrictions covering and running with the Property:

Development Limits. Any future master plan or zoning action for any mixed-use development of the Property will incorporate the following restrictions:

1. The residential development of the Property shall be limited to a maximum of 323 residential units. The residential intensity and uses shall further be defined as depicted on the attached Exhibit "B."
2. The maximum floor area of Commercial development (including, but not limited to, boat sales, offices, showrooms, and related uses) shall be limited to 510,000 square feet.

Declaration of Restrictions
Page 2

(Space reserved for Clerk)

3. Marina use (including boat storage, boat repair, and slips) shall be limited to a maximum of 75,000 square feet of buildings and 15 wet slips
4. The maximum floor area on the Property will be 650,000 square feet (including all uses, residential, commercial, and marina-related buildings) and may not, in aggregate, generate more than 1,377 PM peak hour external vehicle trips.
5. Subject to City approval, the Owner shall set aside the portion of the Property north of NE 16 Street for public park purposes. The design of the park and terms of the dedication shall be determined through the rezoning process. In the event that the City does not accept the proffered dedication, the parcel shall be incorporated as parking for the proposed development.
6. Marina Uses will be retained on the south side of the waterway as depicted in the Exhibit "B". These uses shall include the existing dry storage building. Redevelopment of the parcel for other significant marine service or storage use may be approved by the City provided the proposed redevelopment complies with Comprehensive Plan Policies 10.03.02 and 10.03.03 (which are Coastal Zone Management Element policies related to maintaining marine and water-dependent uses on the waterfront). No residential development will occur on the south parcel.
7. The MUR land use category allows both vertical and horizontal mixed use. To ensure some of the property is developed as vertical mixed use, at least 10,000 square feet of commercial space will be vertically integrated with multi-family residential uses in the mixed-use development plan for the Property. The mixed-use development will meet the City's definition and thresholds in the mixed-use development (MUR) land use category.
8. The design of any redevelopment on the Property will incorporate one or more visual and/or pedestrian connections between Federal Highway and the waterway. Any such connection will be designed not to unduly interfere with existing water-based uses, such as boat storage and repair.
9. Any portion of a residential building on the Property that is located within fifty (50) feet of residential uses or zoning existing as of the date of this Declaration will be

Declaration of Restrictions
Page 3

(Space reserved for Clerk)

limited in height to three (3) stories or thirty-five (35) feet. Outside of these areas, height of any development will be subject to the relevant airport height controls.

10. The design of any redevelopment on the Property will incorporate the relevant Design Guidelines set forth in the MUR Land Use Category in Section 3.02(Q)(2) of the Pompano Beach Comprehensive Plan's Land Use Element. The following elements shall be included in any redevelopment:

- a. Buildings will have minimal setbacks and directly address surrounding streets in order to delineate streetwalls.
- b. All new buildings abutting Federal Highway will have their primary frontage on that right of way and will include elements to create an interesting experience for pedestrian activity, including transparent glazing, architectural features or both on the first floor of a building fronting toward the street, wider sidewalks, and street furniture.
- c. Buildings shall be designed and oriented to encourage pedestrian activity along Federal Highway and NE 23 Avenue.
- d. Pedestrian access points shall be provided across NE 15 Street, NE 16 Street, and NE 23 Avenue in a manner to encourage access to and from the development. Subject to the appropriate governmental approvals, the Applicant will integrate traffic calming solutions on NE 23 Avenue.
- e. Short term and long-term bicycle parking will be provided.
- f. Dumpsters and loading areas shall be located away from existing residential property to greatest extent possible.
- g. Subject to the appropriate governmental approvals, transit amenities, such as an enhanced bus stop and City water taxi stop, shall be provided.

Hurricane Evacuation Plan. The Owner will create a hurricane evacuation plan for the residential and marina use of the Property at the time of site plan approval.

Airpark Issues. The Owner will submit the required Airspace Study Checklist to the Federal Aviation Administration ("FAA") prior to construction activity and will obtain an Air Park Obstruction Permit, if required. The Owner will also provide written notification of the

Declaration of Restrictions
Page 4

(Space reserved for Clerk)

proximity of the Airpark in any leases or deeds for residential units to ensure that eventual residents are aware of potential noise impacts.

Local Workforce Hiring. The Owner shall use all commercially reasonable efforts to (i) utilize the local business community as well as the local workforce in the development of the Property; (ii) recruit and retain qualified community based small businesses; (iii) hire and ensure the retention of qualified employees regardless of race, color, religion, ancestry, national origin, sex, pregnancy, age, disability, marital status, familial status or sexual orientation, and (iv) achieve an aspirational goal of awarding at least 10% of the construction contracts (based on the total construction costs of the project) to minority businesses to the extent permitted by law. The Owner agrees to hire a consulting firm with expertise in this area to manage and assist with the development and administration of the ongoing programming, as a good a faith effort to guarantee its overall success.

Covenant Running with the Land. This Declaration on the part of the Owner shall constitute a covenant running with the land and shall be recorded, at Owner's expense, in the public records of Broward County, Florida and shall remain in full force and effect and be binding upon the undersigned Owner, and their heirs, successors and assigns until such time as the same is modified or released. These restrictions during their lifetime shall be for the benefit of, and limitation upon, all present and future owners of the real property and for the benefit of the City and the public welfare. The Owner, and their heirs, successors and assigns, acknowledge that acceptance of this Declaration does not in any way obligate or provide a limitation on the City.

Term. This Declaration is to run with the land and shall be binding on all parties and all persons claiming under it.

Modification, Amendment, Release. This Declaration of Restrictions may be modified, amended or released as to the land herein described, or any portion thereof, by a written instrument executed by the then owner(s) of the fee simple title to all of the Property, provided that the same is also approved by the City. Any such modification or release shall be subject to the provisions governing amendments to Comprehensive Plans, as set forth in Chapter 163, Part II, Florida Statutes or successor legislation that may, from time to time, govern amendments to Comprehensive Plans (hereinafter "Chapter 163"). Should this Declaration be so modified, amended, or released, the Director of the Development Services Department or the executive

Declaration of Restrictions
Page 5

(Space reserved for Clerk)

officer of a successor department, or, in the absence of such Director or executive officer, by his or her assistant in charge of the office in his/her office, shall execute a written instrument effectuating and acknowledging such modification, amendment, or release.

Enforcement. Enforcement of the covenants contained herein, shall be by action against any parties or person violating, or attempting to violate, any covenants. The prevailing party in any action or suit pertaining to or arising out of this declaration shall be entitled to recover, in addition to costs and disbursements allowed by law, such sum as the Court may adjudge to be reasonable for the services of his attorney. This enforcement provision shall be in addition to any other remedies available at law, in equity or both.

Authorization for City to Withhold Permits and Inspections. In the event the terms of this Declaration are not being complied with, in addition to any other remedies available, the City is hereby authorized to withhold any further permits and refuse to make any inspections or grant any approvals, until such time as this declaration is complied with and any violations issued accordingly.

Election of Remedies. All rights, remedies and privileges granted herein shall be deemed to be cumulative and the exercise of any one or more shall neither be deemed to constitute an election of remedies, nor shall it preclude the party exercising the same from exercising such other additional rights, remedies or privileges.

Severability. Invalidation of any one of these covenants, by judgment of Court, shall not affect any of the other provisions that shall remain in full force and effect. However, if any material portion is invalidated, the City shall be entitled to revoke any approval predicated upon the invalidated portion

Recordation and Effective Date. This Declaration shall be filed of record in the public records of Broward County, Florida at the cost of the Owner following the approval of the Application. This Declaration shall become effective immediately upon recordation. Notwithstanding the previous sentence, if any appeal is filed, and the disposition of such appeal results in the denial of the Application, in its entirety, then this Declaration shall be null and void and of no further effect. Upon the disposition of an appeal that results in the denial of the Application, in its entirety, and upon written request, the Director of the Development Services Department or the executive officer of the successor of said department, or in the absence of such

Declaration of Restrictions
Page 6

(Space reserved for Clerk)

director or executive officer by his/her assistant in charge of the office in his/her absence, shall forthwith execute a written instrument, in recordable form, acknowledging that this Declaration is null and void and of no further effect.

Acceptance of Declaration. The Owner acknowledges that acceptance of this Declaration does not obligate the City in any manner, nor does it entitle the Owner to a favorable recommendation or approval of any application, zoning or otherwise, and the City Commission retains its full power and authority to deny each such application in whole or in part and decline to accept any conveyance.

Owner. The term Owner shall include all heirs, assigns, and successors in interest.

[Execution Pages Follow]

(Space reserved for Clerk)

ACKNOWLEDGEMENT BY LIMITED LIABILITY COMPANY

Signed, witnessed, executed and acknowledged on this 11th day of January 2019

IN WITNESS WHEREOF AMP IV - Hidden Harbour, LLC has caused these presents to be signed in its name by its proper officials.

Witnesses:

[Signature]
 Signature
Alena Pierre
 Print Name
[Signature]
 Signature
RICHARD MATACON
 Print Name

AMP IV - Hidden Harbour, LLC

Address:
2890 NE 187 Street
Aventura, FL 33180

[Signature]
By

Print Name: Andrew S. Sturner

Title: Authorized Person

STATE OF FLORIDA

COUNTY OF MIAMI-DADE

The foregoing instrument was acknowledged before me by Andrew S. Sturner of AMP IV – Hidden Harbour, LLC, a Florida Limited Liability Company. He/she is personally known to me or has produced _____, as identification.

Witness my signature and official seal this 11th day of January, 2019, in the County and State aforesaid.

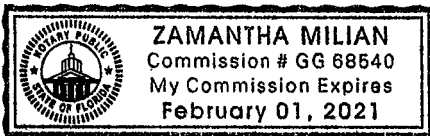

My Commission Expires:

Zamantha Milian
 Signature
 Notary Public-State of Florida
Zamantha Milian
 Print Name

P&Z

01.20

JOINDER BY MORTGAGEE CORPORATION

The undersigned BankUnited, N.A., as Mortgagee under that certain Amended and Restated Mortgage, Assignment of Leases and Rents, Security Agreement and Fixture Filing from AMP IV - Hidden Harbour, LLC dated October 11, 2012 and recorded in Official Records Book 49155, Page 1398 of the Public Records of Broward County, Florida as modified by that certain Future Advance and Mortgage Modification Agreement dated June 23, 2016, and recorded as Instrument Number 113815463 in the Public Records of Broward County, Florida, as further modified by that certain Second Future Advance and Mortgage Modification Agreement dated December 28, 2017, and recorded as Instrument Number 114803875 in the Public Records of Broward County, Florida, covering all of the property described in the Unified Control Agreement and Release of Unity of Title, does hereby acknowledge that the terms of this agreement are and shall be binding upon the undersigned and its successors in title. Nothing contained herein shall be construed to render BankUnited, N.A., or its successors or assigns responsible or liable for the performance of any of the covenants or undertakings of the Unified Control Agreement and Release of Unity of Title. None of the representations contained in the Declaration of Restrictions shall be deemed to have been made by the BankUnited, N.A.

IN WITNESS WHEREOF, these presents have been executed this 27 day of January, 2020.

Witnesses:

[Signature]
Signature

MARCO LIGEROS
Print Name

[Signature]
Signature

MAYTEE L-MORALES
Print Name

BankUnited, N.A.

By: [Signature]
Richard Thill, Senior Vice President

Address
7765 NW 148th Street
Miami Lakes, Florida 33016

**STATE OF FLORIDA
COUNTY OF BROWARD**

The foregoing instrument was acknowledged before me by means of physical presence or online notarization by Richard Thill, a Senior Vice President of BankUnited, N.A., on behalf of the bank. He is personally known to me or has produced _____, as identification.

Witness my signature and official seal this 27 day of January, 2020, in the County and State aforesaid.

Notary Public-State of Florida

Jazlynn Bichara
Print Name

My Commission Expires:

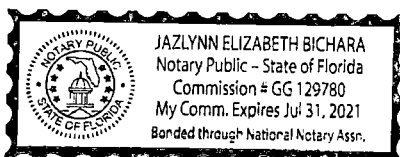

P&Z

EXHIBIT A

NET LAND

(PARCEL 1—comprised of the following parcels designated as Parcels 1A-1F)

(PARCEL 1 A)

All of Parcel "A" of JERICHO BOATS ENTERPRISES, according to the Plat thereof, recorded in Plat book 146, Page 3 of the Public Records of Broward County, Florida.

(PARCEL 1 B)

Lots 1 and 2. Block 2. SEA BARGE YACRT CENTER, according to the Plat thereof, recorded in Plat Book 38, Page 27 of the Public Records of Broad County, Florida. LESS a portion of Lot 1, more particularly described as follows: BEGIN at the Northwest corner of said Lot 1; thence run North 88*29'09" East, along the north line of said Lot 1 for a distance of 17.28 feet; thence run South 47*39'21" West. for a distance of 26.15 feet; thence run North 06*49'35" East along the west line of said Lot 1 for a distance 17.28 feet to the Point of Beginning. PLUS the South 1/2 of the vacated N.E. 15th Street, lying north of Lot 1, Block 2, SEA BARGE YACHT CENTER, according to the Plat thereof, recorded in Plat Book 38, Page 27 of the Public Records of Broward County, Florida.

(PARCEL 1 C)

All of Block 3, LESS the south 265.00 feet thereof, SEA BARGE YACHT CENTER, according to the Plot thereof as recorded in Plat Book 38, Page 27 of the Public Records of Broward County, Florida. Plus the South 1/2 of the vacated N.E. 15 Street, lying North of Block 3, SEA BARGE YACHT CENTER, according to the Plat thereof as recorded in Plat Book 38, Page 27 of the Public Records of Broward County, Florida.

(PARCEL 1 D)

Lots 1, 2, 6, 7 and 8, in Block 1 and all of Tracts "A", "B", "C. and "D" of SEA BARGE YACHT CENTER, according to the Plat thereof, recorded in Plat Book 38, Page 27 of the Public Records of Broward County, Florida.

LESS that portion of Lot 8, Block 1 of SEA BARGE YACHT CENTER, according to the Plat thereof, recorded in Plat Book 38, Page 27 of the Public Records of Broward County, Florida, in Section 30, Township 48 South, Range 43 East, being more particularly described as follows: COMMENCING at the Southeast (SE) corner of said Lot 8; thence run South 88*29 09' West along the South line of said Lot 8, for a distance of 117.71 feet to the POINT OF BEGINNING; thence continue to run South 88*29'09" West a distance of 13.00 feet to the Southwest (SW) corner of said Lot 8; thence run North 06*49'35" East along the west line of said Lot 8, a distance of 13.00 feet; thence run South 42*20'38" East, a distance of 17.00 feet to the POINT OF BEGINNING. PLUS the north 1/2 of the vacated N.E. 15th Street. lying south of Lot 8. Block 1 of SEA BARGE YACHT CENTER. according to the Plat thereof, recorded

P&Z

PZ21-13000006

1/26/2022

in Flat Book 38, Page 27 of the Public Records of Broward County, Florida. PLUS the North ½ of the vacated N.E. 15 Street, lying South of Tract "D" of SEA BARGE YACHT CENTER, according to the Plat thereof as recorded in Plat Book 38, Page 27 of the Public Records of Broward County, Florida.

(PARCEL 1 E)

That portion of the SEA BARGE YACHT BASIN as shown on the Plat of SEA BARGE YACHT CENTER, as recorded in Plat Book 38, Page 27, of the Public Records of Broward County, Florida, described as follows:

That property lying west of the east line of the West Three Quarters (W 3/4) of the Northwest One—Quarter (NW 1/4) of the Southwest One—Quarter (SW 1/4) of Section 30, Township 48 South, Range 43 East and bounded on the south by the northerly boundary of Tract "D" of said SEA BARGE YACHT CENTER, according to the Plat thereof, recorded in Plat Book 38, Page 27 of the Public Records of Broward County, Florida, bounded on the west by the easterly boundary of Tract "C" of said SEA BARGE YACHT CENTER and bounded on the north by the southerly boundary of Tract "B" of said SEA BARGE YACHT CENTER. Together with that portion of said Sea Barge Yacht Basin described as follows: That portion of Lots 30 and 31 of CALIBAN, according to the Plat Thereof, recorded in Plat Book 27, Page 12 of the Public Records of Broward County, Florida, as bounded on the north by the southern boundary of Tract "B", SEA BARGE YACHT CENTER, according to the Plot thereof, recorded in Plat Book 38, Page 27 of the Public Records of Broward County, Florida, bounded on the west by the east line of the West Three-Quarters (W 3/4) of the Northwest One-Quarter (NW 1/4) of the Southwest One-Quarter (SW 1/4) of said Section 30, bounded on the east by a line 10.00 feet west of and parallel to the east line of said Tract "B" of said SEA BARGE YACRT CENTER.

(PARCEL 1F)

Lot 4 of CALIBAN, according to the Plat thereof as recorded in Plat Book 27, at Page 12 of the Public Records of Broward County, Florida.

(PARCEL 2)

Lots 3, 4 and 5, Block 1, of SEA BARGE YACHT CENTER, according to the Plat thereof, as recorded in Plat Book 38, Page 27, of the Public Records of Broward County, Florida.

(PARCEL 3)

A portion of the Caliban Yacht Basin, CALIBAN, according to the plat thereof as recorded in Plat Book 27, Page 12, of the Public Records of Broward County, Florida lying North of and adjacent to Parcel "A", JERICHO BOATS ENTERPRISES, according to the plat thereof as recorded in Plat Book 146, Page 3, of the Public Records of Broward County, Florida and being more fully described as follows:

P&Z

PZ21-13000006

1/26/2022

BEGINNING at the Northeast corner of said Parcel "A", JERICHO BOATS ENTERPRISES; thence South 88*14'47" West on the North line of said Parcel "A" also on the South line of Caliban Yacht Basin, a distance of 327.60 feet to the Northwest corner of said Parcel "A", JERICHO BOATS ENTERPRISES; thence North 00*57'15" West, on the Northerly extension of the west line of said Parcel "A", JERICHO BOATS ENTERPRISES, a distance of 15.00 feet; thence North 88*14'47" East on a line 15.00 feet North of and parallel with the North Line of said Parcel "A", JERICHO BOATS ENTERPRISES, a distance of 327.60 feet; thence South 00*57'23" East, a distance of 15.00 feet to the POINT OF BEGINNING.

(PARCEL 4)

A portion of Lot 1, Block 2, SEA BARGE YACHT CENTER, according to the Plat thereof, as recorded in Plat Book 38, Page 27, of the Public Records of Broward County, Florida, being more particularly described as follows:

BEGIN at the Northwest corner of said Lot 1; thence run North 88*29'09" East, along the north line of said Lot 1 for a distance of 17.28 feet; thence run South 47*39'21. West, for a distance of 26.15 feet; thence run North 06*49'35" East, along the west line of said Lot 1 for a distance of 17.28 feet to the Point of Beginning.

Said lands situate in the City of Pompano Beach, Broward County, Florida and containing 300,444 square feet (6.90 net acres) more or less.

P&Z

PZ21-13000006

1/26/2022

FUTURE LAND USE EXHIBIT
HIDDEN HARBOUR MARINA
 2315 NE 23RD AVE
 POMPANO BEACH, BROWARD COUNTY, FLORIDA

Exhibit B

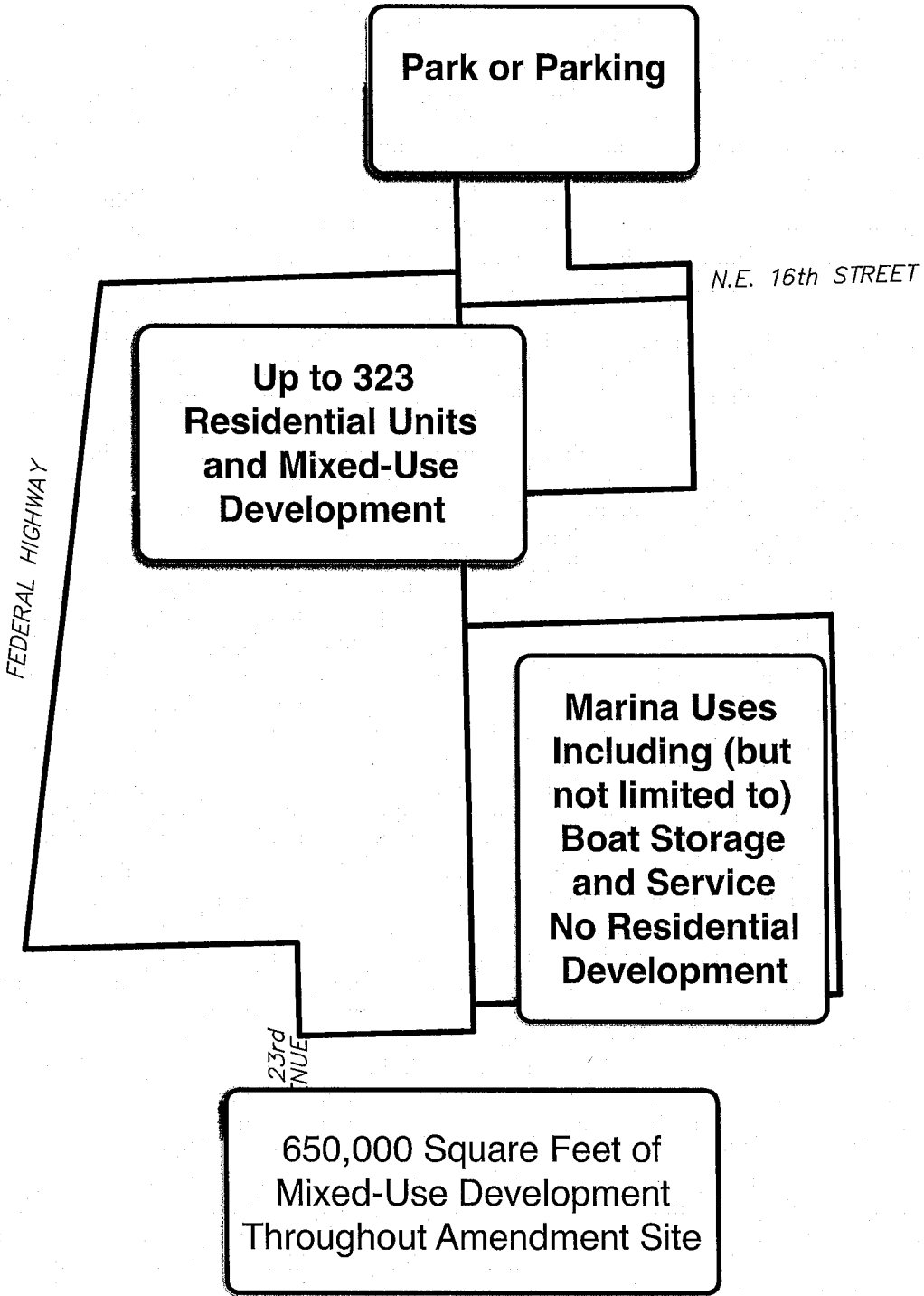

REVISIONS

P&Z

PZ21-13000006
 1/26/2022



AVIROM & ASSOCIATES, INC.
 SURVEYING & MAPPING
 50 S.W. 2nd AVENUE, SUITE 102
 BOCA RATON, FLORIDA 33432
 TEL. (561) 392-2594, FAX (561) 394-7125
 www.AVIROMSURVEY.com

© 2015 AVIROM & ASSOCIATES, INC. all rights reserved.
 This sketch is the property of AVIROM & ASSOCIATES, INC.
 and should not be reproduced or copied without written permission.

JOB #:	7184-21
SCALE:	1" = 150'
DATE:	10/08/2015
BY:	
CHECKED:	
F.B. --- PG. --	
SHEET:	1 OF 1



P&Z

PZ21-1300006
HIDDEN HARBOUR
1/20/2022

EXHIBIT H
STREET SECTIONS

P&Z

PZ21-13000006

HIDDEN HARBOUR

1/10/2012

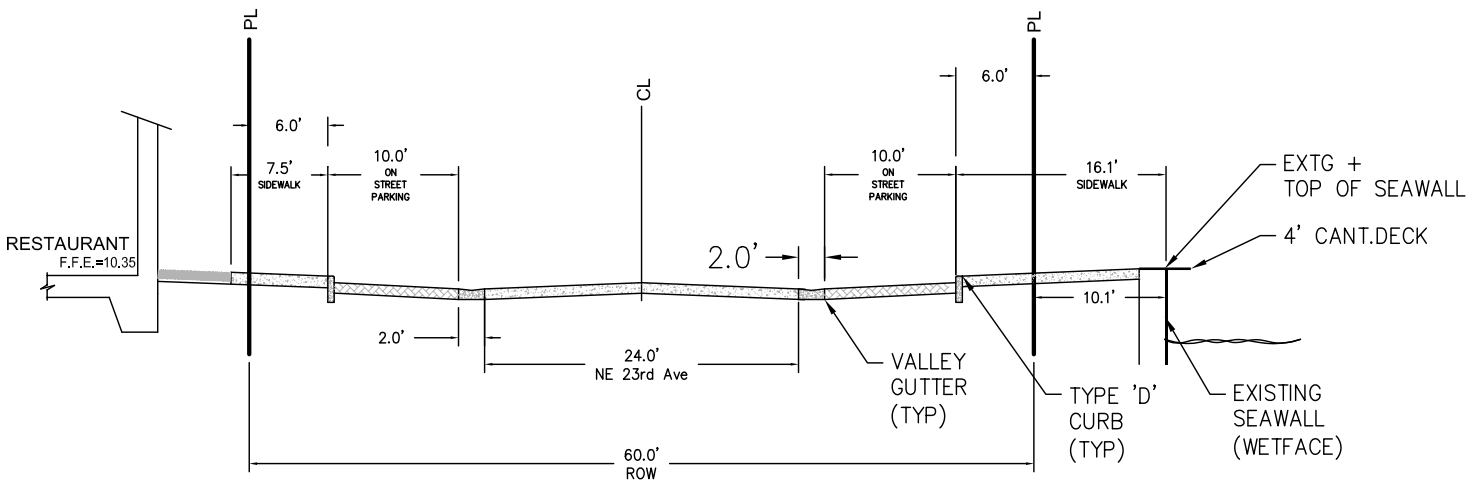
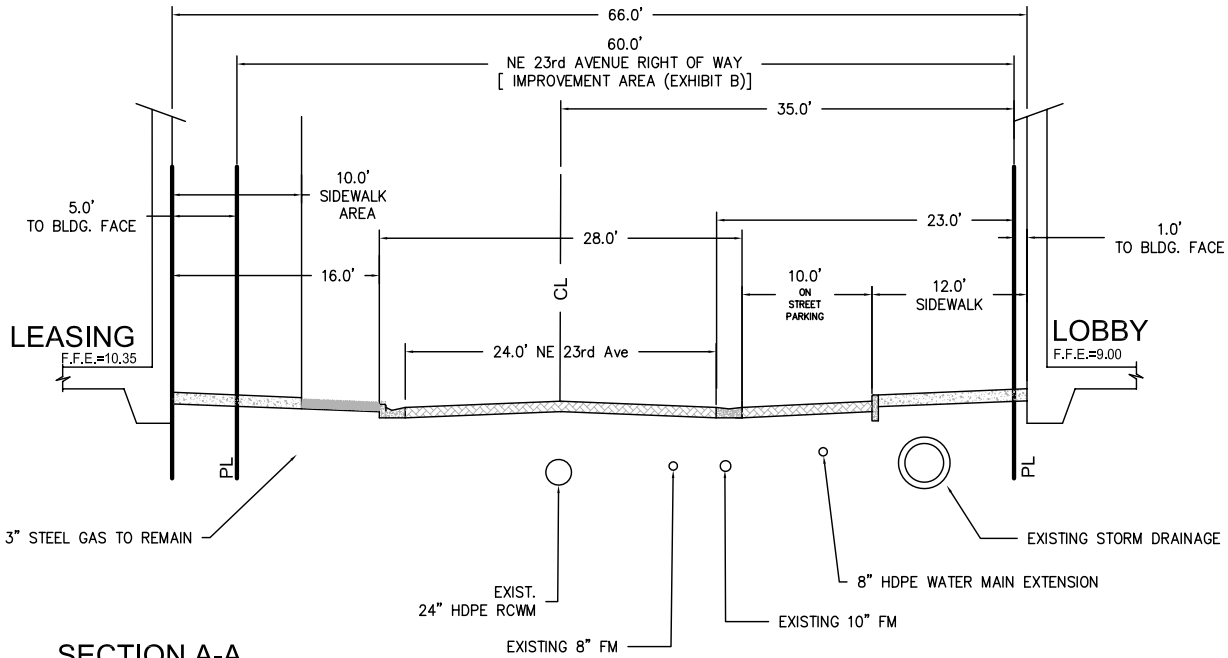



P&Z

PZ21-13000006
HIDDEN HARBOUR
1/20/22

EXHIBIT I
SCHOOL CONSISTENCY REVIEW REPORT



P&Z

PZ21-13000006

HIDDEN HARBOUR

1/10/2012

The School Board of Broward County, Florida
PRELIMINARY SCHOOL CAPACITY AVAILABILITY DETERMINATION

SITE PLAN

SBBC-3110-2021

Municipality Number: TBD

Harborside at Hidden Harbor

July 21, 2021



Growth Management
Facility Planning and Real Estate Department
600 SE 3rd Avenue, 8th Floor
Fort Lauderdale, Florida 33301
Tel: (754) 321-2177 Fax: (754) 321-2179
www.browardschools.com

P&Z

PZ21-13000006

**PRELIMINARY SCHOOL CAPACITY AVAILABILITY DETERMINATION
SITE PLAN**

PROJECT INFORMATION	NUMBER & TYPE OF PROPOSED UNITS	OTHER PROPOSED USES	STUDENT IMPACT
Date: July 21, 2021	Single-Family:		Elementary: 3
Name: Harborside at Hidden Harbor	Townhouse:		Middle: 3
SBBC Project Number: SBBC-3110-2021	Garden Apartments:		
County Project Number: N/A	Mid-Rise: 271		High: 10
Municipality Project Number: TBD	High-Rise:		
Owner/Developer: AMP IV-Hidden Harbour, LLC	Mobile Home:		Total: 16
Jurisdiction: Pompano Beach	Total: 271		

SHORT RANGE - 5-YEAR IMPACT

Currently Assigned Schools	Gross Capacity	LOS * Capacity	Benchmark** Enrollment	Over/Under LOS	Classroom Equivalent Needed to Meet LOS	% of LOS*** Capacity	Cumulative Reserved Seats
Pompano Beach	615	672	438	-190	0	69.7%	14
Pompano Beach Middle	1,227	1,227	1,059	-168	-3	86.3%	13
Blanche Ely High	2,786	3,065	2,037	-1,028	-41	66.5%	13

Currently Assigned Schools	Adjusted Benchmark	Over/Under LOS-Adj. Benchmark Enrollment	% LOS Cap. Adj. Benchmark	Projected Enrollment				
				21/22	22/23	23/24	24/25	25/26
Pompano Beach	452	-176	72%	484	473	461	452	445
Pompano Beach Middle	1,072	-60	87.4%	1,061	1,071	1,082	1,062	1,053
Blanche Ely High	2,050	-1,015	66.9%	2,048	2,017	1,984	1,948	1,945

Students generated are based on the student generation rates contained in the currently adopted Broward County Land Development Code. Information contained herein is current as of the date of review. A traditional cohort survival methodology is used to project school-by-school District traditional school enrollment out over the next five years, and a proportional share of charter school enrollment is used to project future charter school enrollment by school level Districtwide. For more information: <http://www.broward.k12.fl.us/dsa/EnrollmentProj.shtml>. The annual benchmark enrollment is taken on the Monday following Labor Day and is used to apply individual charter school enrollment impacts against school facility review processes.

This number represents the higher of: 100% gross capacity or 110% permanent capacity. **The first Monday following Labor Day. ***Greater than 100% exceeds the adopted Level of Service (LOS).

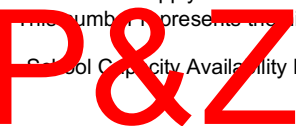

CHARTER SCHOOL INFORMATION

Charter Schools within 2-mile radius	2020-21 Contract Permanent Capacity	2020-21 Benchmark Enrollment	Over/(Under)	Projected Enrollment		
				21/22	22/23	23/24
Somerset Pines Academy	500	440	-60	440	440	440

PLANNED AND FUNDED CAPACITY ADDITIONS IN THE ADOPTED DISTRICT EDUCATIONAL FACILITIES PLAN

School(s)	Description of Improvements
Pompano Beach	There are no classroom additions scheduled in the ADEFP that will increase the reflected FISH capacity.
Pompano Beach Middle	There are no classroom additions scheduled in the ADEFP that will increase the reflected FISH capacity.
Blanche Ely High	There are no classroom additions scheduled in the ADEFP that will increase the reflected FISH capacity.

Students generated are based on the student generation rates contained in the currently adopted Broward County Land Development Code. Information contained herein is current as of the date of review. A traditional cohort survival methodology is used to project school-by-school District traditional school enrollment out over the next five years, and a proportional share of charter school enrollment is used to project future charter school enrollment by school level Districtwide. For more information: <http://www.broward.k12.fl.us/dsa/EnrollmentProj.shtml>. The benchmark enrollment count taken on the first Monday following Labor Day is used to apply individual charter school enrollment impacts against school facility review processes.

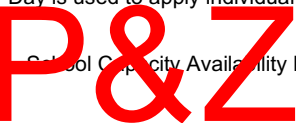

Comments

According to the application, there are no existing units on the site. The application proposes 271 (two or more bedroom) mid-rise units, which will generate 16 (3 elementary, 2 middle and 1 high school) students.

The school Concurrency Service Areas (CSA) serving the project site in the 2020/21 school year include Pompano Beach Elementary, Pompano Beach Middle, and Blanche Ely High Schools. Based on the Public School Concurrency Planning Document (PSCPD), all three schools are currently operating below the Level of Service Standard (LOS), which is established as the higher of: 100% gross capacity or 110% permanent capacity. Incorporating the cumulative students anticipated from this project and approved and vested developments anticipated to be built within the next three years (2020/21- 2022/23), these schools are expected to maintain their current status through the 2022/23 school year. Additionally, the school capacity or Florida Inventory of School Houses (FISH) for the impacted schools reflects compliance with the class size constitutional amendment.

In the 2020/21 school year, the charter schools located within a two-mile radius of the site and their associated data are depicted above. Students returning, attending or anticipated to attend charter schools are factored into the five-year student enrollment projections for District schools. Enrollment projections are adjusted for all elementary, middle and high schools impacted by a charter school until the charter school reaches full enrollment status.

To ensure maximum utilization of the impacted CSAs, the Board may utilize other options such as school boundary changes to accommodate students generated from developments in the County.

Capital Improvements scheduled in the currently Adopted District Educational Facilities Plan (DEFP), Fiscal Years 2020/21 to 2024/25 regarding pertinent impacted schools are depicted above.

Therefore, this application is determined to satisfy public school concurrency on the basis that adequate school capacity is anticipated to be available to support the residential development as currently proposed by the applicant. This preliminary determination shall be valid until the for 180 days for a maximum of 271 (two or more bedroom) mid-rise units and conditioned upon final approval by the applicable governmental body. As such, this preliminary determination will expire on January 16, 2021. This preliminary school concurrency determination shall be deemed to be void unless prior to the referenced expiration of the Preliminary School Capacity Availability Determination (SCAD), notification of final approval to the District has been provided and/or an extension of this Preliminary SCAD has been requested in writing and granted by the School District. Upon the District's receipt of sufficient evidence of final approval which shall specify at the minimum the number, type and bedroom mix for the approved residential units, the District will issue and provide a final SCAD letter for the approved units, which shall ratify and commence the vesting period for the approved residential project.

Please be advised that if a change is proposed to the development, which increases the number of students generated by the project, the additional students will not be considered vested for public school concurrency.

SBBC-3110-2021 Meets Public School Concurrency Requirements

Yes No

Reviewed By:

7/21/2021

Date

Lisa Wight

Signature

Lisa Wight

Name

Planner

Title



Amendment PC 18-5

Site

**POMPANO
BEACH**

NE 18 STREET

NE 16 STREET

FEDERAL HIGHWAY

NE 15 STREET

NE 23 AVENUE

NE 14 STREET



NOT TO SCALE

P&Z



P&Z

EXHIBIT J
CORRIDOR VIEW DIMENSIONS

P&Z

PZ21-13000006

HIDDEN HARBOUR

BY	
<p>HARBORSIDE AT HIDDEN HARBOUR FOR: AMP IV-HIDDEN HARBOUR, LLC LOCATED AT: POMPANO BEACH, FLORIDA</p>	
<p>BEATRIZ M. HERNANDEZ AR0094576</p>	
<p>MSA ARCHITECTS, INC. AACC000895 8950 SW 74th COURT MIAMI, FLORIDA 33156 (305) 273-9811</p>	
<p>MSA ARCHITECTS ARCHITECTURE & PLANNING</p>	
<p><small>COPYRIGHT © 2019 MSA ARCHITECTS, INC. THE ARCHITECTURAL DESIGN AND DETAIL DRAWINGS FOR THIS BUILDING AND/OR OVERALL PROJECT ARE THE LEGAL PROPERTY OF AND ALL RIGHTS ARE RESERVED BY THE ARCHITECT. THEIR USE FOR REPRODUCTION, CONSTRUCTION, OR DISTRIBUTION IS PROHIBITED UNLESS AUTHORIZED IN WRITING BY THE ARCHITECT.</small></p>	
DRAWN	---
DATE	---
SCALE	AS SHOWN
JOB NO.	1828
SHEET TITLE: VIEW CORRIDORS	
SHEET NUMBER: EX - J	



CONCEPTUAL VIEW FROM MARINA LOOKING WEST TOWARDS N.FED HWY

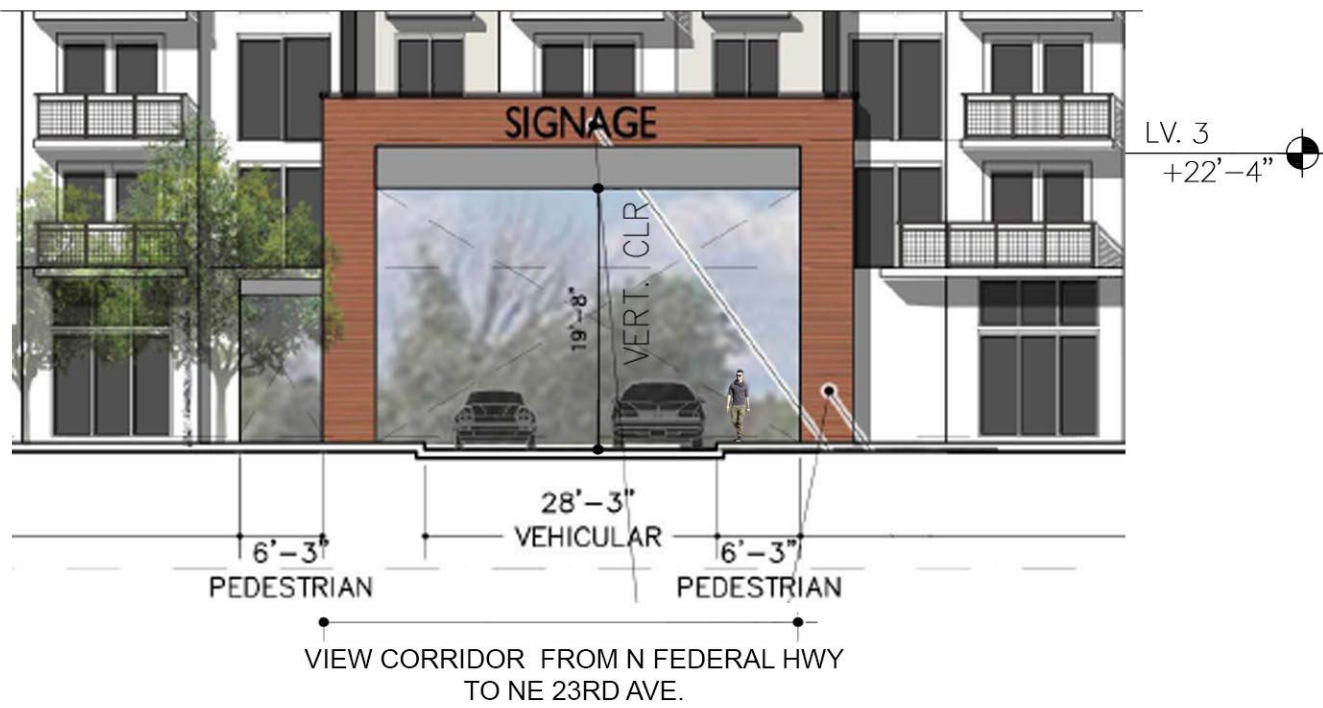

VIEW CORRIDOR FROM N FEDERAL HWY TO NE 23RD AVE.

VIEW CORRIDOR #1 DIAGRAM

1

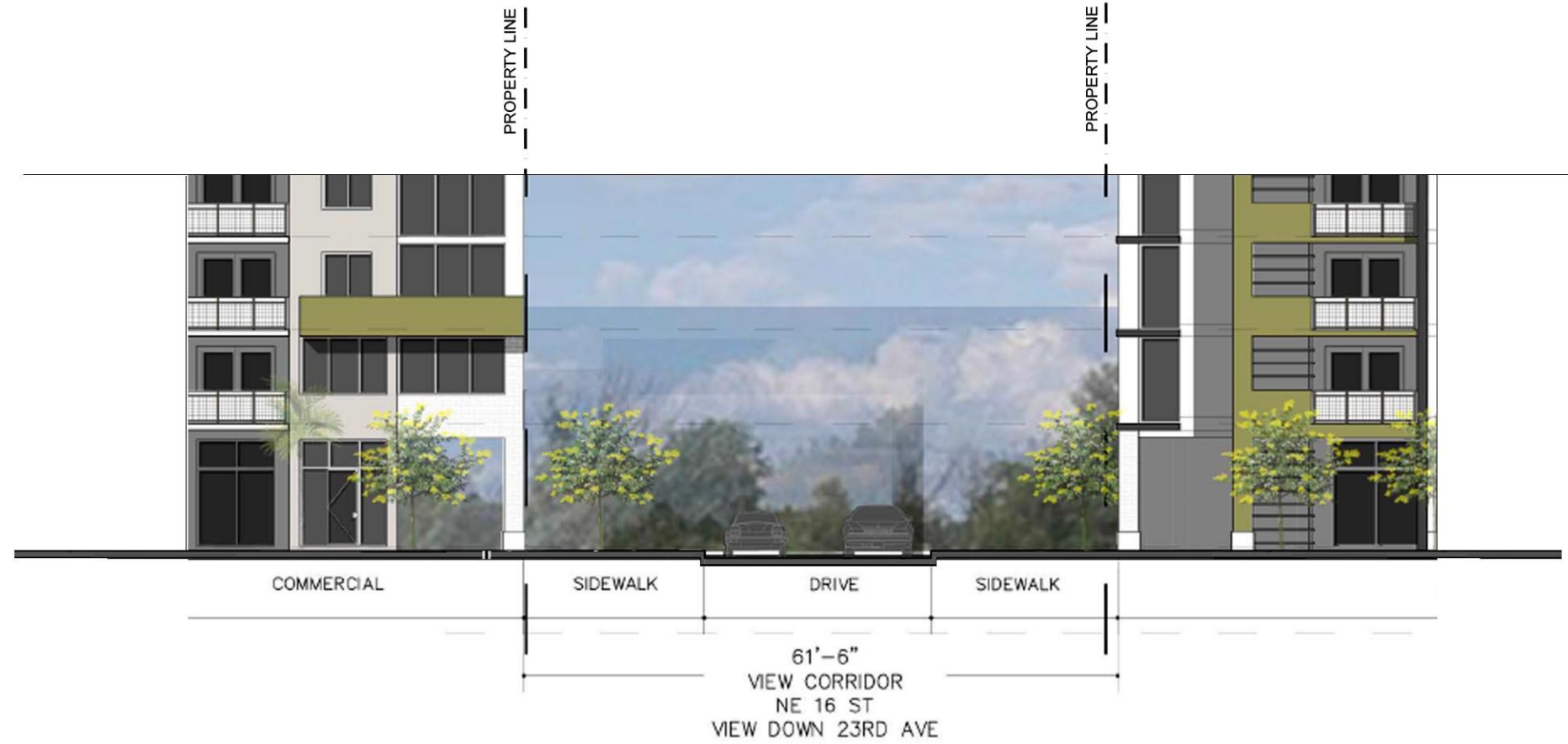

61'-6"
VIEW CORRIDOR
NE 16 ST
VIEW DOWN 23RD AVE

VIEW CORRIDOR #2 DIAGRAM

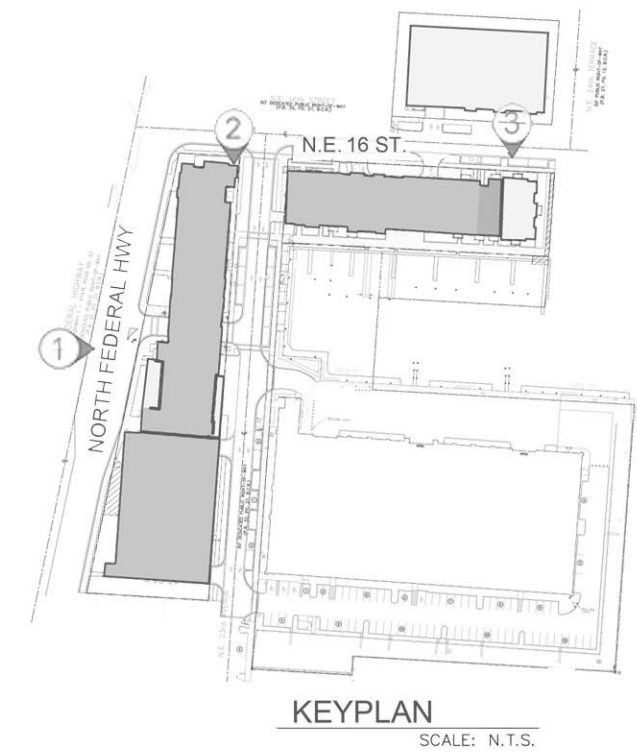

KEYPLAN
SCALE: N.T.S.

P&Z

PZ21-13000006
1/26/2022



P&Z

EXHIBIT K
AIRPORT AIRSPACE HEIGHT LIMIT

P&Z

PZ21-13000006

HIDDEN HARBOUR

1/10/2022

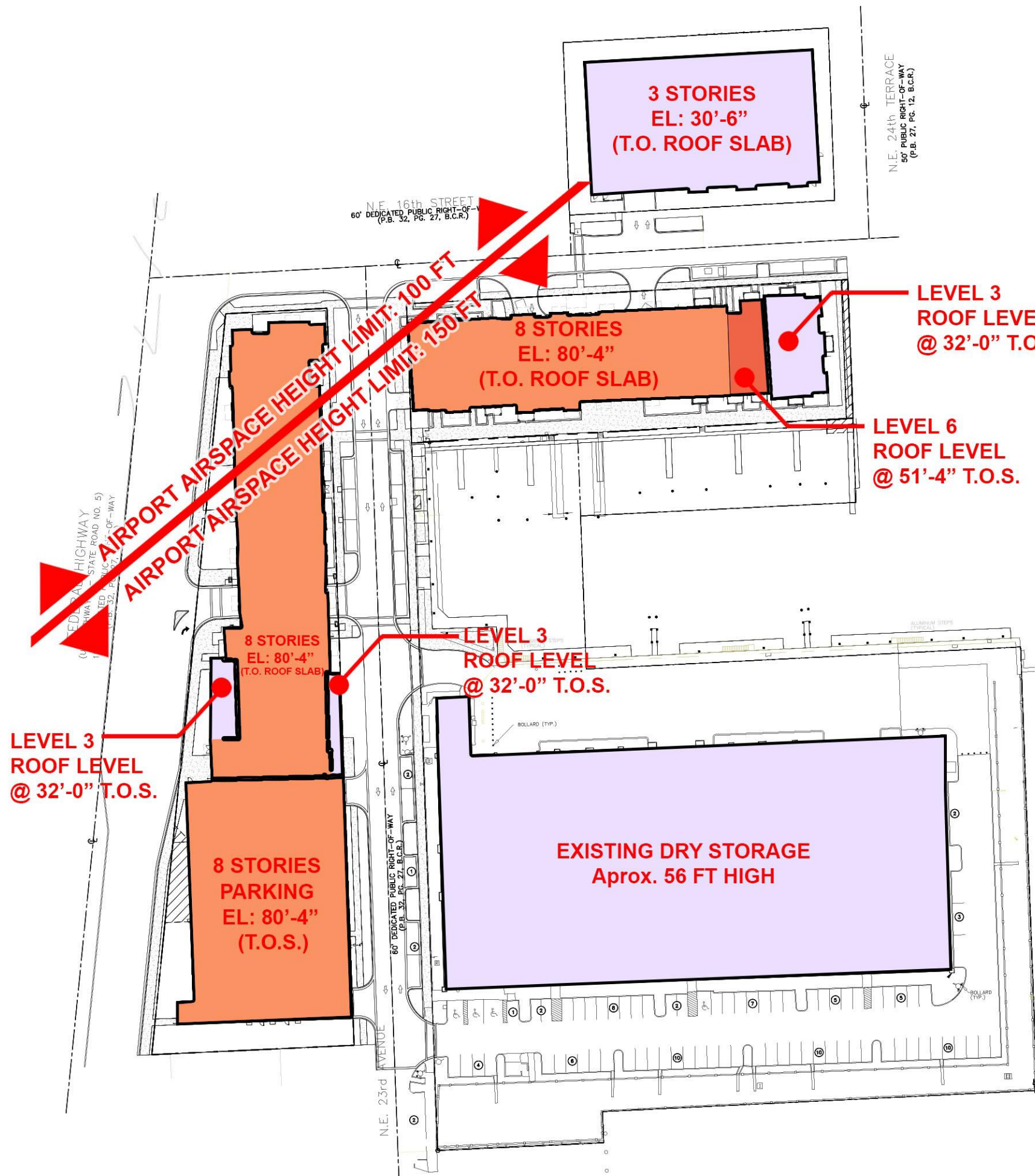

LEGEND

- 8 STORIES
- 6 STORIES
- 1-3 STORIES

NOTE:
 - PROJECT SHALL INCORPORATE A BDA SYSTEM INTO BOTH BUILDINGS
 - FOR FDC REFER TO CIVIL SITE PLAN

<p>ARCHITECT'S BUILDING CODE STATEMENT/ TO THE BEST OF THE ARCHITECT'S KNOWLEDGE THE PLANS AND SPECIFICATIONS COMPLY WITH THE FLORIDA BUILDING CODE SIXTH EDITION (2017) AND THE APPLICABLE FIRE SAFETY STANDARDS AS DETERMINED BY THE LOCAL AUTHORITY AND CHAPTER 633, FLORIDA STATUTES.</p>	<p>BY</p>
<p>HARBORSIDE AT HIDDEN HARBOUR FOR: AMP IV-HIDDEN HARBOUR, LLC LOCATED AT: POMPANO BEACH, FLORIDA</p>	
<p>BEATRIZ M. HERNANDEZ AR0094576</p>	
<p>MSA ARCHITECTS, INC. AAC000895 8950 SW 74th COURT MIAMI, FLORIDA 33156 (305) 273-9911</p>	
<p>MSA ARCHITECTS ARCHITECTURE & PLANNING</p>	
<p>COPYRIGHT © 2019 MSA ARCHITECTS, INC. THE ARCHITECTURAL DESIGN AND DETAIL DRAWINGS FOR THIS BUILDING AND/OR OVERALL PROJECT ARE THE LEGAL PROPERTY OF AND ALL RIGHTS ARE RESERVED BY THE ARCHITECT. THEIR USE FOR REPRODUCTION, CONSTRUCTION, OR DISTRIBUTION IS PROHIBITED UNLESS AUTHORIZED IN WRITING BY THE ARCHITECT.</p>	
<p>DRAWN _____ DATE _____ SCALE AS SHOWN JOB NO. 1828 SHEET TITLE: DIAGRAMS SHEET NUMBER: EX - K</p>	





P&Z

EXHIBIT L
TRUCK TURNING RADIUS

P&Z

PZ21-13000006

HIDDEN HARBOUR

1/10/2022

Drawing name: P&Z 05-0606.06 SITE PD.dwg
 Sep 28, 2021 1:53 PM

P&Z

PZ21-1306.006
 1/26/2022

- LEGEND:**
- 0.00 PROPOSED ELEVATION (NAVD)
 - EXISTING ELEVATION (NAVD)
 - PROPOSED CATCH BASIN
 - PROPOSED PLUG
 - TEE
 - WATER METER
 - DOUBLE DETECTOR CHECK W/ WAFER CHECK VALVE ON DOWNSTREAM SIDE
 - REDUCED PRESSURE BACKFLOW PREVENTOR
 - DIRECTIONAL FLOW ARROW AND GRAVITY SEWER
 - PROPOSED MANHOLE
 - WATER MAIN
 - SANITARY FORCE MAIN
 - VALVE
 - FIRE HYDRANT
 - SIAMESE CONNECTION
 - CLEANOUT
 - EDGE OF PROPOSED PAVEMENT (ASPHALT)
 - DIRECTION OF SURFACE DRAINAGE
 - SAMPLE POINT
 - EXIST. WATER MAIN
 - EXIST. UTILITY LINE TO BE REMOVED

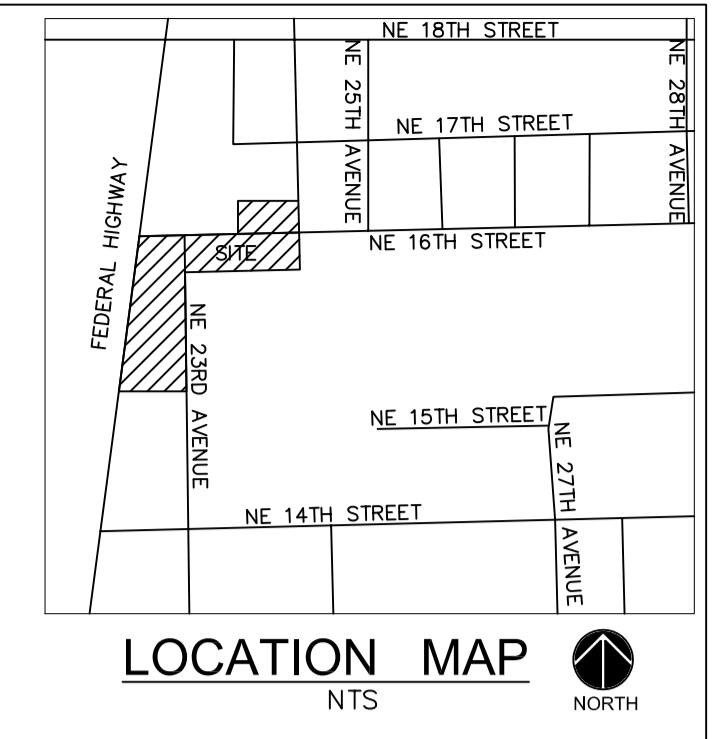
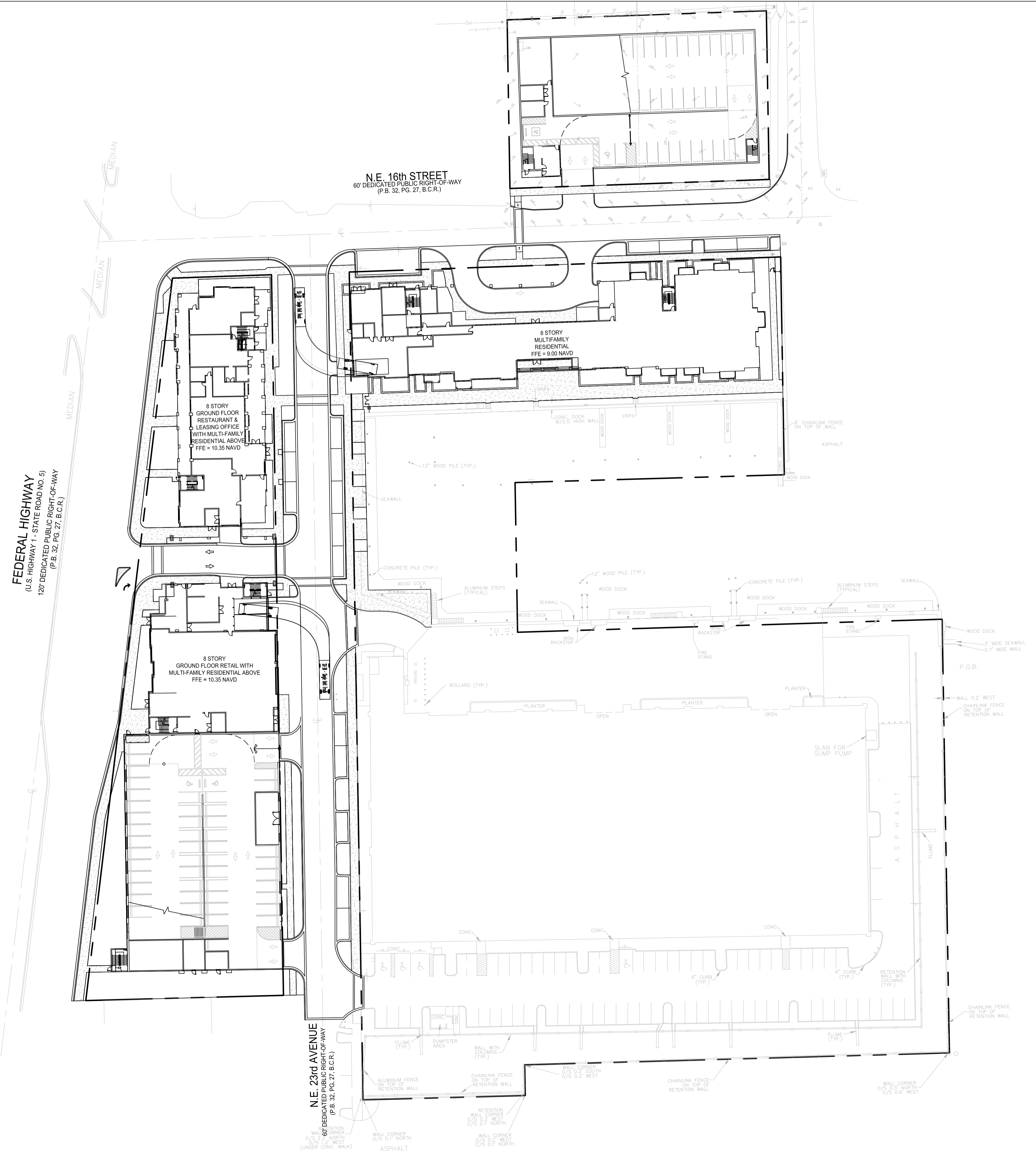

FLYNN

ENGINEERING

241 COMMERCIAL BLD., LAUDERDALE-BY-THE-SEA, FL 33308
 PHONE: (954) 522-1004 | WWW.FLYNNENGINEERING.COM
 EBF 6578

Job Title

TRUCK EXHIBIT

Job Title

HIDDEN HARBOR

POMIPANO BEACH, FLORIDA 33062

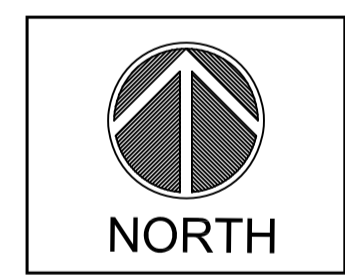

Revisions

Phase:
DRC DOCUMENTS

SEAL	
Scale: 1"=40'	Date 09/28/21
Job No. 05-0606.07	Plt Date 09/28/21
Drawn by SHG	Sheet No. EX-L
Proj. Mgr. SHG	Appr. by SHG
3 of 3	



P&Z

PZ21-13000006
HIDDEN HARBOUR
1/20/2022