

## **CONTRACT FOR PROFESSIONAL CONSULTING SERVICES**

---

---

This Contract is made on \_\_\_\_\_, by and between the City of Pompano Beach, a municipal corporation of the State of Florida, hereinafter referred to as “CITY,” and McCafferty Brinson Consulting, LLC., a Florida corporation authorized to do business in the State of Florida, hereinafter referred to as the “Consultant”.

**WHEREAS**, the Consultant is able and prepared to provide such services as City requires under the terms and conditions set forth herein; and

**WHEREAS**, the City Commission has approved the recommendation that Consultant be employed by the City and authorized the negotiation of contractual terms.

**NOW, THEREFORE**, in consideration of the mutual promises herein, the City and the Consultant agree as follows:

### **ARTICLE 1 – SERVICES/CONSULTANT AND CITY REPRESENTATIVES**

The Consultant’s responsibility under this Contract is to provide professional consulting services as more specifically set forth in RLI No. 25-072 attached hereto as Exhibit “A” and incorporated herein in its entirety.

The Consultant’s representative shall be Audra I. McCafferty,

The CITY’s representative shall be City Engineer or designee,

### **ARTICLE 2 – TERM**

The CONSULTANT shall adhere to the schedule given in each work authorization after receiving the “Notice to Proceed.”

Reports and other items shall be delivered or completed in accordance with the detailed schedule set forth in individual Work Authorizations as negotiated.

The Term of this Contract shall be for an initial period of five (5) years from the date of execution by both the City and the Consultant.

### **ARTICLE 3 – PAYMENTS TO CONSULTANT**

A. City agrees to pay Consultant in consideration for its services described herein. It is the intention of the parties hereby to ensure that unless otherwise directed by the City in writing, Consultant will continue to provide services as specified in Exhibit “A” for the term of this Contract.

B. Price Formula. City agrees to pay Consultant as negotiated on a Work Authorization basis. Each work authorization shall specifically identify the scope of the work to be performed and the fees for said services. As set forth in RLI No. 25-072, professional services under this contract will be restricted to the amounts required by §287.055, Florida Statutes.

C. Fee Determination. Each individual Work Authorization may be negotiated for fees to be earned by Time and Materials with a Not to Exceed Amount, Lump Sum, or a combination of both methods for subtasks contained therein. The total amount to be paid by the City under a Work Authorization shall not exceed specified amounts for all services and materials including “out of pocket” expenses as specified in Paragraph E below and also including any approved subcontracts unless otherwise agreed in writing by both parties. The Consultant shall notify the City’s Representative in writing when ninety (90%) of the “not to exceed amount” for the total Work Authorization has been reached. The Consultant will bill the City on a monthly basis, or as otherwise provided. Time and Materials billing will be made at the amounts set forth in Exhibit “B” for services rendered toward the completion of the Scope of Work. Where incremental billings for partially completed items are permitted, the total billings shall not exceed the estimated percentage of completion as of the billing date. It is acknowledged and agreed to by the Consultant that the dollar limitation set forth in this section is a limitation upon and describes the maximum extent of City’s obligation to pay Consultant, but does not include a limitation upon Consultant’s duty to perform all services set forth in Exhibit “A” for the total compensation in the amount or less than the guaranteed maximum stated above.

D. Invoices received by the City from the Consultant pursuant to this Contract will be reviewed and approved in writing by the City’s Representative, indicating that services have been rendered in conformity with the Contract, and then will be sent to the City’s Finance Department for payment. All invoices shall contain a detailed breakdown of the services provided for which payment is being requested. In addition to detailed invoices, upon request of the City’s representative, Consultant shall provide City with detailed periodic Status Reports on the project. All invoice payments by City shall be made after the Work has been verified and completed. Unless disputed by City as provided herein, upon City’s receipt of a Proper Invoice as defined in §218.72, Florida Statutes, as amended, City shall forward Consultant payment for work performed within forty-five (45) days for all goods and services provided.

City may temporarily remove for review any disputed amount, by line item, from an invoice and shall timely provide Consultant written notification of any such disputed charge. Consultant shall provide clarification and a satisfactory explanation to City, along with revised copies of all such documents if inaccuracies or errors are discovered, within ten (10) days of receipt of City’s notice of the disputed amount.

In the event City has a claim against Consultant for Work performed hereunder which has not been timely remedied in accordance with the provisions of this Article 3, City may withhold payment for the contested amount, in whole or in part, to protect itself from loss on account of defective Work, claims filed or reasonable evidence indicating probable filing of claims by other parties against Consultant, and/or Consultant’s failure to make proper payments to subcontractors or vendors for material or labor. When the reason(s) for withholding payment are removed or resolved in a manner satisfactory to City, payment shall be made.

E. “Out-of-pocket” expenses shall be reimbursed up to an amount not to exceed amounts included in each Work Authorization. All requests for payment of “out-of-pocket” expenses eligible for reimbursement under the terms of this Contract shall include copies of paid receipts, invoices, or other documentation acceptable to the City’s Representative and to the Finance Department. Such documentation shall be sufficient to establish that the expense was actually incurred and necessary in the performance of the Scope of Work described in a Work Authorization and this Contract. All out-of- pocket, reimbursables and expenses shall be billed at actual amount paid by Consultant, with no markup.

F. Final Invoice. In order for both parties herein to close their books and records, the Consultant will clearly state “Final Invoice” on the Consultant’s final/last billing to the City. This final invoice shall also certify that all services provided by Consultant have been properly performed and all charges and costs have been invoiced to the City. Because this account will thereupon be closed, any and other further charges not properly included on this final invoice are waived by the Consultant.

#### **ARTICLE 4 – CONTRACT DOCUMENTS**

This Agreement consists of the Solicitation set forth in Exhibit “A”, the Consultant’s Response set forth in Exhibit “B” (collectively, the “Work”) and, the Insurance Requirements set forth in Exhibit “C,” all of which are attached and made a part of this Agreement. It is further agreed that no modification, amendment or alteration in the terms or conditions contained herein shall be effective unless contained in a written document executed with the same formality and off equal dignity herewith. None of the provisions, terms and conditions contained in this Contract may be added to, modified, superseded or otherwise altered, except by written instrument executed by the parties hereto in accordance with Article 26 – Modification of Work. In the event of any conflict or inconsistency between this Agreement and the provisions in the incorporated Exhibits, resolution shall be attained by giving precedence in the following order: (i) this Agreement, (ii) Exhibit “A”, and (iii) Exhibit “C”.

#### **ARTICLE 5 – TRUTH-IN-NEGOTIATION CERTIFICATE**

Signature of this Contract by the Consultant shall also act as the execution of a truth in negotiation certificate, certifying that the wage rates, overhead charges, and other costs used to determine the compensation provided for this Contract are accurate, complete and current as of the date of the Contract and no higher than those charged the Consultant’s most favored customer for the same or substantially similar service. Should the City determine that said rates and costs were significantly increased due to incomplete, non-current or inaccurate representation, then said rates shall be adjusted accordingly.

## **ARTICLE 6 – TERMINATION**

City shall have the right to terminate this Contract, in whole or in part, for convenience, cause, default or negligence on Consultant's part, upon ten (10) business days advance written notice to Consultant. Such Notice of Termination may include City's proposed Transition Plan and timeline for terminating the Work, requests for certain Work product documents and materials, and other provisions regarding winding down concerns and activities.

If there is any material breach or default in Consultant's performance of any covenant or obligation hereunder which has not been remedied within ten (10) business days after City's written Notice of Termination, City, in its sole discretion, may terminate this Contract immediately and Consultant shall not be entitled to receive further payment for services rendered from the effective date of the Notice of Termination.

In the event of termination, City shall compensate Consultant for all authorized Work satisfactorily performed through the termination date under the payment terms set forth in Article 3 above and all Work product documents and materials shall be delivered to City within ten (10) business days from the Notice of Termination. If any Work hereunder is in progress but not completed as of the date of the termination, then upon City's written approval, this Contract may be extended until said Work is completed and accepted by City.

This Contract may be cancelled by the Consultant, upon thirty (30) days prior written notice to the City's Representative, in the event of substantial failure by the City to perform in accordance with the terms of this Contract through no fault of the Consultant.

## **ARTICLE 7 – PERSONNEL**

The Consultant is, and shall be, in the performance of all work services and activities under this Contract, an independent Contractor, and not an employee, agent or servant of the City. All persons engaged in any of the work or services performed pursuant to this Contract shall at all times, and in all places, be subject to the Consultant's sole direction, supervision, and control and shall not in any manner be deemed to be employees of the City. The Consultant shall exercise control over the means and manner in which it and its employees perform the work. This contract does not create a partnership or joint venture between the parties.

The Consultant represents that it has, or will secure at its own expense, all necessary personnel required to perform the services under this Contract. Such personnel shall not be employees of or have any contractual relationship with the City, nor shall such personnel be subject to any withholding for tax, Social Security or other purposes by the City, nor be entitled to any benefits of the City including, but not limited to, sick leave, pension benefits, vacation, medical benefits, life insurance, workers or unemployment compensation benefits, or the like from the City.

All of the services required hereunder shall be performed by the Consultant or under its supervision, and all personnel engaged in performing the services shall be fully qualified and, if required, authorized or permitted under state and local law to perform such services.

Any changes or substitutions in the Consultant's key personnel, as may be listed in Article 1, must be made known to the City's Representative at the time substitution becomes effective.

The Consultant warrants that all services shall be performed by skilled and competent personnel to the degree exercised by consultants performing the same or similar services in the same location at the time the services are provided.

#### **ARTICLE 8 – SUBCONTRACTING**

Consultant may subcontract any services or work to be provided to City with the prior written approval of the City's Representative. The City reserves the right to accept the use of a subcontractor or to reject the selection of a particular subcontractor and to inspect all facilities of any subcontractors in order to make determination as to the capability of the subcontractor to perform properly under this Contract. The City's acceptance of a subcontractor shall not be unreasonably withheld. The Consultant is encouraged to seek small business enterprises and to utilize businesses that are physically located in the City of Pompano Beach with a current Business Tax Receipt for participation in its subcontracting opportunities.

#### **ARTICLE 9 – FEDERAL AND STATE TAX**

The City is exempt from payment of Florida State Sales and Use Taxes. The City will provide the Consultant with the current state issued exemption certificate. The Consultant shall not be exempted from paying sales tax to its suppliers for materials used to fulfill contractual obligations with the City, nor is the Consultant authorized to use the City's Tax Exemption Number in securing such materials.

The Consultant shall be responsible for payment of its own and its share of its employees' payroll, payroll taxes and benefits with respect to this Contract

#### **ARTICLE 10 – AVAILABILITY OF FUNDS**

The City's performance and obligation to pay under this Contract is contingent upon appropriation for various projects, tasks and other professional services by the City Commission.

#### **ARTICLE 11 - INSURANCE REQUIREMENTS**

The Consultant shall not commence work under this Contract until it has obtained all insurance required under this paragraph and such insurance has been approved by the Risk Manager of the City, nor shall the Consultant allow any Subcontractor to commence work on its sub-contract until the aforementioned approval is obtained.

CERTIFICATE OF INSURANCE, reflecting evidence of the required insurance, shall be filed with the Risk Manager prior to the commencement of the work. The Certificate shall contain a provision that coverage afforded under these policies will not be cancelled, will not expire and will not be materially modified until at least thirty (30) days prior written notice has been given to the City. Policies shall be issued by companies authorized to conduct business under the laws of

the State of Florida and shall have adequate Policyholders and Financial ratings in the latest ratings of A. M. Best and be part of the **Florida Insurance Guarantee Association Act**.

Insurance shall be in force until all work required to be performed under the terms of the Contract is satisfactorily completed as evidenced by the formal acceptance by the City. In the event the Insurance Certificate provided indicates that the insurance shall terminate and lapse during the period of this Contract, the Consultant shall furnish, at least ten (10) days prior to the expiration of the date of such insurance, a renewed Certificate of Insurance as proof that equal and like coverage for the balance of the period of the Contract and extension thereunder is in effect. The Consultant shall not continue to work pursuant to this Contract unless all required insurance remains in full force and effect.

Limits of Liability for required insurance are shown in Exhibit "C."

The City of Pompano Beach must be named as an additional insured for the Automobile and Commercial General Liability Coverage.

For Professional Liability, if coverage is provided on a claims made basis, then coverage must be continued for the duration of this Contract and for not less than one (1) year thereafter, or in lieu of continuation, provide an "extended reporting clause" for one (1) year.

Consultant shall notify the City Risk Manager in writing within thirty (30) days of any claims filed or made against the Professional Liability Insurance Policy.

For Workers' Compensation Insurance, coverage shall be maintained during the life of this Contract to comply with statutory limits for all employees, and in the case of any work sublet, the Consultant shall require any Subcontractors similarly to provide Workers' Compensation Insurance for all the latter's employees unless such employees are covered by the protection afforded by the Consultant. The Consultant and his Subcontractors shall maintain during the life of this Contract Employer Liability Insurance.

## **ARTICLE 12 – INDEMNIFICATION**

A. Consultant shall at all times indemnify, hold harmless the City, its officials, officers, employees, volunteers and other authorized agents from and against any and all claims, demands, suit, damages, attorneys' fees, fines, losses, penalties, defense costs or liabilities suffered by the City to the extent caused by any negligent act, omission, breach, recklessness or misconduct of Consultant and/or any of its agents, officers, or employees hereunder, including any inaccuracy in or breach of any of the representations, warranties or covenants made by the Consultant, its agents, officers and/or employees, in the performance of services of this contract. To the extent considered necessary by City, any sums due Consultant hereunder may be retained by City until all of City's claims for indemnification hereunder have been settled or otherwise resolved, and any amount withheld shall not be subject to payment or interest by City.

B. Consultant acknowledges and agrees that City would not enter into this Contract without this indemnification of City by Consultant. The parties agree that one percent (1%) of the total compensation paid to Consultant hereunder shall constitute specific consideration to Consultant for the indemnification provided under this Article and these provisions shall survive expiration or early termination of this Contract.

C. Nothing in this Agreement shall constitute a waiver by the City of its sovereign immunity limits as set forth in section 768.28, Florida Statutes. Nothing herein shall be construed as consent from either party to be sued by third parties.

### **ARTICLE 13 – SUCCESSORS AND ASSIGNS**

The City and the Consultant each binds itself and its partners, successors, executors, administrators and assigns to the other party of this Contract and to the partners, successors, executors, administrators and assigns of such other party, in respect to all covenants of this Contract. Except as above, neither the City nor the Consultant shall assign, sublet, encumber, convey or transfer its interest in this Contract without prior written consent of the other. Nothing herein shall be construed as creating any personal liability on the part of any officer or agent of the City, which may be a party hereto, nor shall it be construed as giving any rights or benefits hereunder to anyone other than the City and the Consultant.

### **ARTICLE 14 – REMEDIES**

The laws of the State of Florida shall govern this Contract. Any and all legal action between the parties arising out of the Contract will be held in Broward County. No remedy herein conferred upon any party is intended to be exclusive of any other remedy, and each and every such remedy shall be cumulative and shall be in addition to every other remedy given hereunder or now or hereafter existing at law or in equity or by statute or otherwise. No single or partial exercise by any party of any right, power or remedy hereunder shall preclude any other or further exercise thereof.

### **ARTICLE 15 – CONFLICT OF INTEREST**

The Consultant represents that it has no interest and shall acquire no interest, either direct or indirect, which would conflict in any manner with the performance of services required hereunder, as provided for in the Code of Ethics for Public Officers and Employees (Chapter 112, Part III, Florida Statutes). The Consultant further represents that no person having any interest shall be employed for said performance.

The Consultant shall promptly notify the City's representative, in writing, by certified mail, of a potential conflict(s) of interest for any prospective business association, interest or other circumstance, which may influence or appear to influence the Consultant's judgment or quality of services being provided hereunder. Such written notification shall identify the prospective business association, interest or circumstance, the nature of work that the Consultant may undertake and request an opinion of the City as to whether the association, interest or circumstance would, in the opinion of the City, constitute a conflict of interest if entered into by the Consultant. The City agrees to notify the Consultant of its opinion by certified mail within thirty (30) days of

receipt of notice by the Consultant. If, in the opinion of the City, the prospective business association, interest, or circumstance would not constitute a conflict of interest by the Consultant, the City shall so state in the notice and the Consultant shall at its option, enter into said association, interest or circumstance and it shall be deemed not a conflict of interest with respect to services provided to the City by the Consultant under the terms of this Contract.

#### **ARTICLE 16 – EXCUSABLE DELAYS**

The Consultant shall not be considered in default by reason of any failure in performance if such failure arises out of causes reasonably beyond the control of the Consultant or its subcontractors and without their fault or negligence. Such causes include, but are not limited to, acts of God; natural or public health emergencies; freight embargoes; and abnormally severe and unusual weather conditions.

Upon the Consultant’s request, the City shall consider the facts and extent of any failure to perform the work and, if the Consultant’s failure to perform was without it, or its subcontractors fault or negligence, the Contract Schedule and/or any other affected provision of this Contract shall be revised accordingly; subject to the City’s rights to change, terminate, or stop any or all of the work at any time.

#### **ARTICLE 17 – DEBT**

The Consultant shall not pledge the City’s credit or attempt to make it a guarantor of payment or surety for any contract, debt, obligation, judgment, lien or any form of indebtedness. The Consultant further warrants and represents that it has no obligation or indebtedness that would impair its ability to fulfill the terms of this Contract.

#### **ARTICLE 18 – DISCLOSURE AND OWNERSHIP OF DOCUMENTS**

The Consultant shall deliver to the City’s representatives for approval and acceptance, and before being eligible for final payment of any amounts due, all documents and materials prepared by and for the City under this Contract.

All written and oral information not in the public domain or not previously known, and all information and data obtained, developed, or supplied by the City or at its expense will be kept confidential by the Consultant and will not be disclosed to any other party, directly or indirectly, without the City’s prior written consent unless required by a lawful order. All drawings, maps, sketches, programs, data base, reports and other data developed, or purchased, under this Contract for or at the City’s expense shall be and remain the City’s property and may be reproduced and reused at the discretion of the City.

A. The City of Pompano Beach is a public agency subject to Chapter 119, Florida Statutes. The Consultant shall comply with Florida’s Public Records Law, as amended. Specifically, the Consultant shall:

1. Keep and maintain public records required by the City in order to perform the service.

2. Upon request from the City's custodian of public records, provide the City with a copy of requested records or allow the records to be inspected or copied within a reasonable time at a cost that does not exceed the cost provided in Chapter 119, Florida Statutes or as otherwise provided by law.

3. Ensure that public records that are exempt or confidential and exempt from public records disclosure requirements are not disclosed except as authorized by law for the duration of the contract term and following completion of the contract if the Consultant does not transfer the records to the City.

4. Upon completion of the contract, transfer, at no cost to the City, all public records in possession of the Consultant, or keep and maintain public records required by the City to perform the service. If the Consultant transfers all public records to the City upon completion of the contract, the Consultant shall destroy any duplicate public records that are exempt or confidential and exempt from public records disclosure requirements. If the Consultant keeps and maintains public records upon completion of the contract, the Consultant shall meet all applicable requirements for retaining public records. All records stored electronically must be provided to the City, upon request from the City's custodian of public records in a format that is compatible with the information technology systems of the City.

B. Failure of the Consultant to provide the above described public records to the City within a reasonable time may subject Consultant to penalties under 119.10, Florida Statutes, as amended.

## **PUBLIC RECORDS CUSTODIAN**

**IF THE CONSULTANT HAS QUESTIONS REGARDING THE APPLICATION OF CHAPTER 119, FLORIDA STATUTES, TO THE CONSULTANT'S DUTY TO PROVIDE PUBLIC RECORDS RELATING TO THIS CONTRACT, CONTACT THE CUSTODIAN OF PUBLIC RECORDS AT:**

**CITY CLERK  
100 W. Atlantic Blvd., Suite 253  
Pompano Beach, Florida 33060  
(954) 786-4611  
[RecordsCustodian@copbfl.com](mailto:RecordsCustodian@copbfl.com)**

All covenants, agreements, representations and warranties made herein, or otherwise made in writing by any party pursuant hereto, including but not limited to any representations made herein relating to disclosure or ownership of documents, shall survive the execution and delivery of this Contract and the consummation of the transactions contemplated thereby.

#### **ARTICLE 19 – CONTINGENT FEES**

The Consultant warrants that it has not employed or retained any company or person, other than a bona fide employee working solely for the Consultant to solicit or secure this Contract and that it has not paid or agreed to pay any person, company, corporation, individual, or firm, other than a bona fide employee working solely for the Consultant, any fee, commission, percentage, gift, or any other consideration contingent upon or resulting from the award or making of this Contract. Violation of this Article shall constitute a forfeiture of this Contract by Consultant.

#### **ARTICLE 20 – ACCESS AND AUDITS**

The Consultant shall maintain adequate records to justify all charges, expenses, and cost incurred in estimating and performing the work for at least three (3) years after completion of this Contract. The City shall have access to such books, records and documents as required in this section for the purpose of inspection or audit during normal business hours, at the Consultant's place of business.

#### **ARTICLE 21 – NONDISCRIMINATION**

The Consultant warrants and represents that all of its employees are treated equally during employment without regard to race, color, religion, disability, sex, age, national origin, ancestry, marital status and sexual orientation.

#### **ARTICLE 22 – INTERPRETATION**

The language of this Contract has been agreed to by both parties to express their mutual intent and no rule of strict construction shall be applied to either party hereto. The headings are for reference purposes only and shall not affect in any way the meaning or interpretation of this Contract. All personal pronouns used in this Contract shall include the other gender, and the singular, the plural, and vice versa, unless the context otherwise requires.

#### **ARTICLE 23 – AUTHORITY TO PRACTICE**

The Consultant hereby represents and warrants that it has and will continue to maintain all licenses and approvals required conducting its business, and that it will at all times conduct its business activities in a reputable manner. Proof of such licenses and approvals shall be submitted to the City's representative upon request.

## **ARTICLE 24 – SEVERABILITY**

If any term or provision of this Contract, or the application thereof to any person or circumstances shall, to any extent be held invalid or unenforceable, to remainder of this Contract, or the application of such terms or provision, to persons or circumstances other than those as to which it is held invalid or unenforceable, shall not be affected, and every other term and provision of this Contract shall be deemed valid and enforceable to the extent permitted by law.

## **ARTICLE 25 – ENTIRETY OF CONTRACTUAL AGREEMENT**

The City and the Consultant agree that this Contract, together with the Exhibits hereto, sets forth the entire agreement between the parties, and that there are no promises or understandings other than those stated herein. It is further agreed that no modification, amendment or alteration in the terms or conditions contained herein shall be effective unless contained in a written document executed with the same formality and off equal dignity herewith. None of the provisions, terms and conditions contained in this Contract may be added to, modified, superseded or otherwise altered, except by written instrument executed by the parties hereto in accordance with Article 26 – Modification of Work.

## **ARTICLE 26 – MODIFICATION OF SCOPE OF WORK**

The City reserves the right to make changes in the Scope of Work, including alterations, reductions therein or additions thereto. Upon receipt by the Consultant of the City's notification of a contemplated change, the Consultant shall, in writing: (1) provide a detailed estimate for the increase or decrease in cost due to the contemplated change; (2) notify the City of any estimated change in the completion date; and (3) advise the City if the contemplated change shall affect the Consultant's ability to meet the completion dates or schedules of this Contract.

If the City so instructs in writing, the Consultant shall suspend work on that portion of the Scope of Work affected by a contemplated change, pending the City's decision to proceed with the change.

If the City elects to make the change, the City shall initiate a Work Authorization Amendment and the Consultant shall not commence work on any such change until such written amendment is signed by the Consultant and the City Manager, and if such amendment is in excess of two hundred thousand dollars (\$200,000.00), it must also first be approved by the City Commission and signed by the appropriate City Official authorized by the City Commission

The City shall not be liable for payment of any additional or modified work, which is not authorized in the manner provided for by this Article.

## **ARTICLE 27 – NOTICE**

All notices required in this Contract shall be sent by certified mail, return receipt requested, to the following:

### **FOR CITY:**

Greg Harrison  
City Manager  
City of Pompano Beach  
Post Office Drawer 1300  
Pompano Beach, Florida 33061  
Greg.Harrison@copbfl.com

### **FOR CONSULTANT:**

Audra I. McCafferty, Manager  
633 S. Andrews Ave.  
Suite 402  
Fort Lauderdale, FL 33301  
Office: (954) 797-7100  
Email: amccafferty@mccaffertybrinson.com

## **ARTICLE 28 – OWNERSHIP OF DOCUMENTS**

All finished or unfinished documents, data, reports, studies, surveys, drawings, maps, models and photographs prepared or provided by the Consultant in connection with this Contract shall become property of the City, whether the project for which they are made is completed or not, and shall be delivered by Consultant to City within ten (10) days of notice of termination. If applicable, City may withhold any payments then due to Consultant until Consultant complies with the provisions of this section.

## **ARTICLE 29 – PROMOTING PROJECT OBJECTIVES**

Consultant, its employees, subcontractors, and agents shall refrain from acting adverse to the City's interest in promoting the goals and objectives of the projects. Consultant shall take all reasonable measures necessary to effectuate these assurances. In the event Consultant determines it is unable to meet or promote the goals and objectives of the projects, it shall immediately notify the City and the City, may then in its discretion, terminate this Contract.

## **ARTICLE 30 – PUBLIC ENTITY CRIMES ACT**

As of the full execution of this Contract, Consultant certifies that in accordance with §287.133, Florida Statutes, it is not on the Convicted Vendors List maintained by the State of Florida, Department of General Services. If Consultant is subsequently listed on the Convicted Vendors List during the term of this Contract, Consultant agrees it shall immediately provide City written notice of such designation in accordance with Article 27 above.

## **ARTICLE 31 – GOVERNING LAW; VENUE; WAIVER OF JURY TRIAL**

This Agreement shall be interpreted and construed in accordance with and governed by the laws of the State of Florida. The exclusive venue for any litigation arising from, related to, or in connection with this Agreement shall be in the Seventeenth Judicial Circuit in and for Broward County, Florida, or in the United States District Court for the Southern District of Florida, or the United States Bankruptcy Court for the Southern District of Florida, as applicable. BY ENTERING INTO THIS AGREEMENT, THE PARTIES EXPRESSLY WAIVE ANY RIGHTS EITHER PARTY MAY HAVE TO A TRIAL BY JURY OF ANY CIVIL LITIGATION RELATED TO THIS AGREEMENT.

## **ARTICLE 32 – EMPLOYMENT ELIGIBILITY**

By entering into this Contract, the Consultant becomes obligated to comply with the provisions of Section 448.095, Fla. Stat., "Employment Eligibility." This includes but is not limited to utilization of the E-Verify System to verify the work authorization status of all newly hired employees, and requiring all subcontractors to provide an affidavit attesting that the subcontractor does not employ, contract with, or subcontract with, an unauthorized alien. Failure to comply will lead to termination of this Contract, or if a subcontractor knowingly violates the statute, the subcontract must be terminated immediately. Any challenge to termination under this provision must be filed in the Circuit or County Court no later than twenty (20) calendar days after the date of termination. If this Contract is terminated for a violation of the statute by the Consultant, the Consultant may not be awarded a public contract for a period of one (1) year after the date of termination

## **ARTICLE 33 - BINDING EFFECT**

The benefits and obligations imposed pursuant to this Contract shall be binding and enforceable by and against the parties hereto.

## **ARTICLE 34 - SCRUTINIZED COMPANIES**

By execution of this Agreement, in accordance with the requirements of F.S. 287.135 and F.S. 215.473, Consultant certifies that Consultant is not participating in a boycott of Israel. Consultant further certifies that Consultant is not on the Scrutinized Companies that Boycott Israel list, not on the Scrutinized Companies with Activities in Sudan List, and not on the Scrutinized Companies with Activities in Iran Terrorism Sectors List, nor has Consultant been engaged in business operations in Syria. Subject to limited exceptions provided in state law, the City will not contract for the provision of goods or services with any scrutinized company referred to above. In accordance with Section 287.135, Florida Statutes as amended, a company is ineligible to, and may not, bid on, submit a proposal for, or enter into or renew a contract with any agency or local government entity for goods or services of:

A. Any amount if, at the time of bidding on, submitting a proposal for, or entering into or renewing such contract, the company is on the Scrutinized Companies that Boycott Israel List, created pursuant to Section 215.4725, Florida Statutes, or is engaged in a boycott of Israel; or

B. One million dollars or more if, at the time of bidding on, submitting a proposal for, or entering into or renewing such contract, the company:

i. Is on the Scrutinized Companies with Activities in Sudan List of the Scrutinized Companies with Activities in Iran Terrorism Sectors List, created pursuant to Section 215.473, Florida Statutes; or

ii. Is engaged in business operations in Syria.

C. Submitting a false certification or being placed on a list created pursuant to Section 215.473, Florida Statutes relating to scrutinized active business operations in Iran after Consultant has submitted a certification, shall be deemed a material breach of contract. The City shall provide notice, in writing, to Consultant of the City's determination concerning the false certification. Consultant shall have five (5) days from receipt of notice to refute the false certification allegation. If such false certification is discovered during the active contract term, Consultant shall have ninety (90) days following receipt of the notice to respond in writing and demonstrate that the determination of false certification was made in error. If Consultant does not demonstrate that the City's determination of false certification was made in error then the City shall have the right to terminate the contract and seek civil remedies pursuant to Section 287.135, Florida Statutes, as amended from time to time.

### **ARTICLE 35 - AFFIDAVIT OF COMPLIANCE WITH ANTI-HUMAN TRAFFICKING LAWS**

In accordance with section 787.06 (13), Florida Statutes, the undersigned, on behalf of the entity listed below ("Entity"), hereby attests under penalty of perjury that:

Entity does not use coercion for labor or services as defined in Section 787.06, Florida Statutes, entitled "Human Trafficking".

### **ARTICLE 36 - AFFIDAVIT OF COMPLIANCE WITH FOREIGN ENTITY LAWS**

The undersigned, on behalf of the entity listed below ("Entity"), hereby attests under penalty of perjury as follows:

A. Entity is not owned by the government of a foreign country of concern as defined in Section 287.138, Florida Statutes.

B. The government of a foreign country of concern does not have a controlling interest in Entity.

C. Entity is not organized under the laws of, and does not have a principal place of business in, a foreign country of concern.

D. Entity is not owned or controlled by the government of a foreign country of concern, as defined in Section 692.201, Florida Statutes.

E. Entity is not a partnership, association, corporation, organization, or other combination of persons organized under the laws of or having its principal place of business in a foreign country of concern, as defined in Section 692.201, Florida Statutes, or a subsidiary of such entity.

F. Entity is not a foreign principal, as defined in Section 692.201, Florida Statutes.

G. Entity is in compliance with all applicable requirements of Sections 692.202, 692.203, and 692.204, Florida Statutes.

### **ARTICLE 37 – ANNUAL BUDGETARY FUNDING/CANCELLATION.**

This Agreement and all obligations of the City hereunder requiring the expenditure of funds are subject to and contingent upon annual budgetary funding and appropriations by the City Commission.

**THE REMAINDER OF THE PAGE IS INTENTIONALLY LEFT BLANK**

**“CITY”**

**IN WITNESS WHEREOF**, the parties hereto have caused this Agreement to be executed the day and year hereinabove written.

Attest:

**CITY OF POMPANO BEACH**

\_\_\_\_\_  
KERVIN ALFRED, CITY CLERK

By: \_\_\_\_\_  
REX HARDIN, MAYOR

APPROVED AS TO FORM:

By: \_\_\_\_\_  
GREGORY P. HARRISON, CITY MANAGER

\_\_\_\_\_  
MARK E. BERMAN, CITY ATTORNEY

(SEAL)

**"CONSULTANT"**

**McCafferty Brinson Consulting, LLC.**

Witnesses:

*Amada Esposito*

Signature

Amada Esposito

Name Typed, Printed or Stamped

By: *Audra I. McCafferty*  
Audra I. McCafferty, Manager

*Kyla Booth*

Signature

Kyla Booth

Name Type, Printed or Stamped

STATE OF Florida  
COUNTY OF Broward

The foregoing instrument was acknowledged before me, by means of  physical presence or  online notarization, this 10 day of February, 2026, Audra I. McCafferty, as Manager of McCafferty Brinson Consulting, LLC., a Florida corporation, authorized to do business in Florida, on behalf of the corporation, who is personally known to me or who has produced N/A as identification.

NOTARY'S SEAL:



*Mariell A. Soto*  
NOTARY PUBLIC, STATE OF FLORIDA

Mariell A. Soto  
(Name of Acknowledger Typed, Printed or Stamped)

HH 383781  
Commission Number

**Exhibit A – Cover Page**

**1. Recommendation Tabulation**

**2. Solicitation RLI25-072**

**3. Addendum 1-5**

**4. Sunbiz**



Florida's Warmest Welcome

## Procurement &amp; Contracts Department

Mary Rivero, Director

[mary.rivero@copbfl.com](mailto:mary.rivero@copbfl.com)

RLI #:	<u>RLI25-072</u>	Tentative City Commission Meeting Date*:	<u>TBD</u>
RLI Title:	<u>Water and Reuse Treatment Plant Projects - CCNA</u>	# Notified:	<u>145</u> # Downloaded: <u>14</u>
		# of Responses Rec'd:	<u>6</u> # of "No Bids": <u>1</u>
For:	<u>Utilities</u>	RFP Opening Date:	<u>OCTOBER 15, 2025</u>
	(Department)		

**POSTING OF RFP RECOMMENDATION/TABULATION:** RLI Recommendations and Tabulations will be posted in the eBid System IonWave on December 16, 2025, at 9:10 PM and will remain posted for 72 hours. Any person who may be adversely affected by the decision or intended decision shall file a notice of protest in writing within 72 hours of posting the notice of the decision or intended decision. The formal written protest shall be filed within ten (10) days after the date the notice of protest is filed. Failure to file a notice of protest or a formal written protest shall constitute a waiver of proceedings under this chapter. Section 120.57(3)(b), Florida Statutes, states that "The formal written protest shall state with particularity the facts and law upon which the protest is based." Saturdays, Sundays, state holidays, and days when the City is closed shall be excluded from the computation of the 72-hour time period provided. Filings shall be at the office of the Director of Procurement and Contracts, 1010 NE 3rd Avenue, Pompano Beach, FL 33060. Any person who files an action protesting an intended decision shall post with the City, at the time of filing the formal written protest, a protest bond, payable to the City of Pompano Beach, Florida, in an amount equal to one percent (1%) of the estimated value of the contract. Failure to submit the protest bond within the time allowed for filing a bond shall constitute a waiver of the right to protest. Failure to file a protest within the time prescribed in Section 120.57(3), Florida Statutes, or failure to post the protest bond or other security required by law within the time allowed for filing a bond shall constitute a waiver of proceedings under Chapter 120, Florida Statutes.

(\* ) The Cone of Silence, as stated in the solicitation, is in effect until the City Commission approves or rejects it. Confirm with the Purchasing Agent of record for the date the Cone of Silence has concluded.

## RECOMMENDATION TABULATION

The City of Pompano Beach, Florida, issued Request for Letters of Interest (RLI25-072) Water and Reuse Treatment Plant Projects pursuant to the Consultants' Competitive Negotiation Act (CCNA). The solicitation closed with the receipt of six (6) Letters of Interest, all of which were reviewed and determined to be responsive and responsible submissions.

- ARCADIS US, INC.
- CAROLLO ENGINEERS, INC.
- HAZEN AND SAWYER.
- MCCAFFERTY BRINSON CONSULTING, LLC.
- STANTEC CONSULTING INC.
- TETRA TECH, INC.

On December 16, 2025, the appointed Evaluation Committee convened in accordance with the RLI, Procurement and Contracts Procedure Manual, and the Sunshine Law. The Committee conducted a comprehensive review of all responsive submissions, applying the published evaluation criteria to score and rank each firm.

Based on the evaluation results, the Evaluation Committee hereby recommends an award to the following five (5) highest-ranked firms (\*) under RLI25-072 – Water and Reuse Treatment Plant Projects (CCNA):

FIRM	RANKING
MCCAFFERTY BRINSON CONSULTING, LLC.	1
CAROLLO ENGINEERS, INC.	2
ARCADIS US, INC.	3
HAZEN AND SAWYER (*)	4
STANTEC CONSULTING INC. (*)	5

(\* ) HAZEN AND SAWYER and STANTEC CONSULTING INC. received identical evaluation scores. Accordingly, the Evaluation Committee determined that both firms are recommended for the award.

By: Michael Lee Date: 12/16/2025  
Purchasing Agent



**REQUEST FOR LETTER OF INTEREST  
RLI 25-072**

**WATER AND REUSE TREATMENT PLANT PROJECTS -  
CONTINUING CONTRACTS (CCNA)**

**BID OPENING:  
October 1<sup>st</sup>, 2025, 2:00 PM**

**VIRTUAL PRE-BIDDERS CONFERENCE:  
September 10, 2025, 10:00 AM**

**For access, go to:  
<https://pompanobeachfl.gov/pages/meetings>**

**:**

Issue Date: August 28, 2025

**CITY OF POMPANO BEACH, FLORIDA  
REQUEST FOR LETTER OF INTEREST (RLI)**

**RLI 25-072 WATER AND REUSE TREATMENT PLANT PROJECTS - CONTINUING CONTRACTS (CCNA)**

Pursuant to Section 287.055, Florida Statutes Consultant's Competitive Negotiation Act (CCNA), the City of Pompano Beach (the "City") invites professional companies/firms to submit a Letter of Interest (RLI) to provide engineering services at the Pompano Beach Water Treatment Plant on a continuing as-needed basis.

The selected firm shall demonstrate specific experience and capabilities and must have qualified personnel and expertise in the specified disciplines.

This RLI is subject to the "Cone of Silence," which imposes certain restrictions on communications concerning the RLI process.

The Cone of Silence shall take effect once this solicitation is released to the General Public. Respondents to this solicitation or persons acting on their behalf may not contact, between the release of the solicitation and the end of the 72 hours following the agency posting the notice of intended award, excluding Saturdays, Sundays, and state holidays, any employee or officer of the executive or legislative branch concerning any aspect of this solicitation, except in writing to the procurement officer or as provided in the solicitation documents. Violation of this provision may be grounds for rejecting a response." (F.S. 287.057 (25)).

Any firm or lobbyist for a firm is prohibited from having any communications concerning any solicitation for a competitive procurement with any member of the City Commission, City Clerk, City Manager's Office, any Evaluation Committee Member, or any other City of Pompano Beach employee after Procurement and Contracts releases a solicitation to the General Public. All communications must go through the eBid System (IonWave) or the Purchasing Agent assigned to this solicitation. No other member of the City Commission, City Clerk, City Manager's Office, any Evaluation Committee Member, or any other City of Pompano Beach employee should be contacted concerning this RLI. Any information that amends any portion of this RLI received by any method other than an Addendum issued to the RLI is not binding on the City of Pompano Beach.

The City will receive proposals until **2:00:00 p.m. (EST), October 1, 2025**. Proposals must be submitted electronically through the eBid System (IonWave) on or before the due date and time as provided herein. Any proposal received after the due date and time specified will not be considered. Any uncertainty regarding the time a proposal is accepted will be resolved against the firm.

Firms must be registered on the City's eBid System in order to view the solicitation documents and respond to this Solicitation. The complete solicitation document can be downloaded for free from the eBid System as a PDF at <https://www.pompanobeachfl.ionwave.net>. The City is not responsible for the accuracy or completeness of any documentation the firm receives from any source other than the eBid System. The firm is solely responsible for downloading all required documents. To attend the virtual public meeting, go to <https://www.pompanobeachfl.gov/pages/meetings> to find the Zoom link.

Procurement and Contracts Department  
City of Pompano Beach, Florida

## SCHEDULE OF EVENTS

<b>RLI NUMBER:</b>	<b>RLI25-072</b>
<b>RLI TITLE:</b>	<b>WATER AND REUSE TREATMENT PLANT PROJECTS – CONTINUING CONTRACTS (CCNA)</b>
<b>RELEASE DATE:</b>	<b>8/28/2025, at 12:00 P.M.</b>
<b>PREBIDDERS CONFERENCE VIRTUAL ZOOM MEETING</b>	<b>9/10/2025, at 10:00 A.M.</b>
<b>WRITTEN QUESTIONS AND INQUIRIES ARE DUE ON OR BEFORE:</b>	<b>9/22/2025, at 12:00 P.M.</b>
<b>RLI RESPONSES DUE DATE/TIME:</b>	<b>10/1/2025, at 02:00 P.M.</b>
<b>EVALUATION COMMITTEE MEETINGS</b>	<b>TBD</b>
<b>RECOMMENDATION FOR AWARD:</b>	<b>TBD</b>
<b>DIRECT ALL INQUIRIES TO:</b>	<a href="https://pompanobeachfl.ionwave.net">https://pompanobeachfl.ionwave.net</a>
<b>E-PROPOSAL SUBMITTALS ONLY:</b>	<a href="https://pompanobeachfl.ionwave.net">https://pompanobeachfl.ionwave.net</a>
<b>PROPOSAL VIRTUAL OPENING:</b>	<a href="https://www.pompanobeachfl.gov/meetings">https://www.pompanobeachfl.gov/meetings</a>

### Non-Mandatory Pre-Proposal Meeting

The non-mandatory Pre-Proposal Meeting will be held via a Virtual Zoom Meeting on **9/10/2025, at 10:00 a.m.** (local). The Zoom link is available on the City’s Meetings webpage: <https://www.pompanobeachfl.gov/meetings>

#### **A. Introduction**

The City is seeking professional companies/firms to work on various projects for the Water Treatment Plant. The projects range in magnitude from small-scale to extensive or specialized designs.

The types of projects to be undertaken may include, but are not limited to, the following:

- Reuse Water Treatment Plant Projects
- Water Treatment Plant Projects

#### **B. Compliance with CCNA**

As a result of this RLI, all services provided under the contract must adhere to the latest provisions of the Florida Consultants’ Competitive Negotiation Act (CCNA), as outlined in Section 287.055, Florida Statutes, including any subsequent amendments. The maximum allowable costs for projects or studies conducted under this contract are subject to the limits set by the CCNA, which are periodically adjusted.

The Respondent acknowledges that all services under this contract shall comply with the latest provisions of the Florida Consultants’ Competitive Negotiation Act (CCNA), pursuant to Section 287.055, Florida Statutes, and any amendments.

The maximum allowable costs for projects or studies conducted under this contract shall not exceed the limits

established by the CCNA as periodically adjusted. The limits are calculated annually based on the Consumer Price Index (CPI) or as determined by the Department of Financial Services.

Respondents are responsible for ensuring that their proposals align with the applicable statutory limits in effect at the time of submission and contract execution.

### **C. Scope of Services**

The City intends to engage one or more qualified professional companies/firms to provide continuing consulting and specified works. The scope of services may include, but is not limited to, the following:

1. Prepare studies and recommend methods of operation and/or treatment.
2. Prepare preliminary design reports and/or design alternative recommendations. This may include various types of utility modeling, surveying, and field data analysis.
3. Prepare all required bidding/construction documents for projects. This will include survey, design plan, technical specification, and cost estimate preparations. Attend all required pre-design, design, bidding, and bid award meetings.
4. Attend the pre-bid conference, prepare possible bid addendums for plan revisions, and assist in making bid award recommendations for contracting/construction services.
5. Prepare all required permit applications and submittal packages as required for permit issuance of all agency permits (i.e., State, County, and City).
6. Provide construction engineering/management services for projects. Services during construction may include shop drawing/contractor submittal reviews and approvals, inspection and approval of project improvements, possible plan revisions, and review and approval of contractor pay applications.
7. Provide project close-out services. These may include preliminary and final project acceptance, preparation and approval of punch list items, and project certification as required by all permitting agencies.
8. Firms must have experience in municipal water and reuse treatment plant projects and be licensed to practice Professional Engineering in the State of Florida, Florida State Statute 471, by the Board of Professional Regulation.

### **D. Task/Deliverables**

Tasks and deliverables will be determined per project. Each project shall require the City to receive a signed Work Authorization (WA) form from the awarded company/firm. The forms shall be completed and include the agreed-upon scope, tasks, schedule, cost, and deliverables for the project. The awarded company(s)/firm(s) must provide all applicable insurance requirements.

### **E. Term of Agreement/Contract**

The contracts will be for five (5) years with no renewals, commencing upon award by the appropriate City officials.

#### **F. Project Web Requirements:**

1. This project will utilize the City-provided project management software, a web-based project management tool. This application is a collaboration tool that will allow all project team members continuous access through the Internet to essential project data and up-to-the-minute decision and approval status information. The City's project management software is a comprehensive project and program management system that the City will use to manage all project documents, communications, and costs between the lead consultant, sub-consultants, design consultants, contractors, and the City. City provided project management software includes extensive reporting capabilities to facilitate detailed project reporting in a web-based environment that is accessible to all parties and easy to use. Training will be provided for all companies/firms selected to provide services for the City of Pompano Beach.

2. Lead and sub-consultants shall conduct project controls outlined by the City, project manager, and/or construction manager, utilizing City-provided project management software. The city shall provide the designated web-based application license(s) to the prime consultant and sub-consultants. No additional software will be required.

The lead consultant and sub-consultants shall log into the project website daily and, as necessary, be kept fully apprised of project developments and required action items. These may include but are not limited to: Contracts, Contract Exhibits, Contract Amendments, Drawing Issuances, Addenda, Bulletins, Permits, Insurance & Bonds, Safety Program Procedures, Safety Notices, Accident Reports, Personnel Injury Reports, Schedules, Site Logistics, Progress Reports, Correspondence, Daily Logs, Non-Conformance Notices, Quality Control Notices, Punch Lists, Meeting Minutes, Requests for Information, Submittal Packages, Substitution Requests, Monthly Payment Request Applications, Supplemental Instructions, City Change Directives, Potential Change Orders, Change Order Requests, Change Orders and the like. All supporting data, including but not limited to shop drawings, product data sheets, manufacturer data sheets and instructions, method statements, safety SDS sheets, Substitution Requests, and the like, will be submitted in digital format via p.

#### **G. Required Proposal Submittal**

Sealed proposals shall be submitted electronically through the eBid System on or before the due date and time as provided herein. Firm shall upload the response as one (1) file to the eBid System. The file size for uploads is limited to 250 MB. If the file size exceeds 10 MB, the response must be split and uploaded as two (2) separate files.

**Information to be included in the proposal:** To maintain comparability and expedite the review process, proposals must be organized as specified below, with the sections clearly labeled.

##### **Title page:**

Show the RLI number, the name of the Firm's company/firm, address, telephone number, name of the contact person, and the date.

##### **Table of Contents:**

Include a clear identification of the material by section and by page.

##### **Letter of Transmittal:**

Briefly state the Firm's understanding of the RLI solicitation and express a positive commitment to provide the services described herein. Please state the name(s) of the person(s) who will be authorized to make representations for the Firm, their title(s), office, and email addresses and telephone numbers. Please limit this section to two (2) pages.

**Technical Approach:**

Companies/Firms or teams shall submit their sample technical approach to the tasks described in the solicitation, including details of how each phase of the proposed project would be completed and how their company/firm proposes maintaining time schedules and cost controls.

**References:**

References for past projects aligning with the scope identified in this solicitation in the past seven years. Describe the scope of each project in physical terms and by cost, describe the Firm's responsibilities, and provide the contact information (name, email, telephone number) of an individual in a position of responsibility who can attest to the Firm's activities with the project.

**Project Team Form:**

Prepare and submit a completed "Project Team" form. This form aims to identify the proposed team's key members, including any specialty subconsultants. This information is intended for informational purposes only and does not constitute a contractual offer, obligation, or basis for procurement decisions.

**Organizational Chart:**

Specifically, identify the management plan (if needed) and provide an organizational chart for the project team. The Firm must describe, at a minimum, the basic approach to these projects, including the reporting hierarchy of staff and sub-consultants. Clarify the individual(s) responsible for coordinating separate components of the scope of services.

**Statement of Skills and Experience of Project Team:**

Describe the experience of the entire project team as it relates to the types of projects described in the Scope of Services section of this solicitation. Include the experience of the prime consultants as

well as other project team members, i.e., additional personnel, sub-consultants, branch office, team members, and other resources anticipated to be utilized for this project. Name specific projects [successfully completed within the past five (5) years] where the team members have performed similar projects previously.

**Resumes of Key Personnel:**

Include resumes for key personnel for prime and sub-consultants.

**Office Locations:**

Identify the office's location from which services will be rendered and the number of professional and administrative staff at the prime office. Also, identify the location of office(s) of the prime and/or sub-consultants that may be utilized to support any or all of the professional services listed above, as well as the number of professional and administrative staff at the prime office location.

If companies/firms are situated outside the local area (Broward, Palm Beach, and Miami-Dade counties), include a brief statement as to whether or not the companies/firms will arrange for a local office during the term of the agreement/contract, if necessary.

**Litigation:**

Disclose any litigation within the past five (5) years arising out of your company/firm's performance,

including status/outcome.

**City Forms:**

The Firm Information Page Form and any other required forms must be completed and submitted electronically through the City's eBid System. The City reserves the right to request additional information to ensure the Firm is financially solvent. It has sufficient financial resources to perform the agreement/contract and shall provide proof of its financial solvency. At its sole discretion, the City may ask for additional proof of financial solvency, including additional documents post-proposal opening and prior to evaluation that demonstrate the Firm's ability to perform the resulting agreement/contract and provide the required materials and/or services.

**Reviewed and Audited Financial Statements:**

Firms shall be financially solvent and appropriately capitalized to be able to service the City for the duration of the agreement/contract. Firms shall provide a complete financial statement of the company's/firm's most recent audited financial statements, indicating the organization's financial condition. Must be uploaded to the Response Attachments tab in the eBid System as a separate file titled "FINANCIAL STATEMENTS" and marked "CONFIDENTIAL."

Financial statements provided shall not be older than twelve (12) months before the date of filing this solicitation's response. The financial statements must be reviewed and submitted with any accompanying notes and supplemental information. The City of Pompano Beach reserves the right to reject financial statements in which the financial condition shown is twelve (12) months or more before the submittal date.

The City is a public agency subject to Chapter 119, Florida's Public Records Law, and must provide the public with access to public records; however, financial statements that are required as submittals to prequalify for a solicitation will be exempt from public disclosure.

The City reserves the right to request additional information to ensure the Firm is financially solvent. It has sufficient financial resources to perform the agreement/contract and shall provide proof of its financial solvency. At its sole discretion, the City may ask for additional proof of financial solvency, including additional documents post-proposal opening and prior to evaluation that demonstrate the Firm's ability to perform the resulting agreement/contract and provide the required materials and/or services.

A combination of two (2) or more of the following may substitute for audited financial statements:

- 1) Bank letters/statements for the past three (3) months
- 2) Balance sheet, profit and loss statement, cash flow report
- 3) IRS returns for the last two (2) years
- 4) Letter from CPA showing profits and loss statements (certified)

**H. Insurance**

The contractor/consultant shall not commence services under the terms of this agreement/contract until certification or proof of insurance detailing terms and provisions has been received and approved in writing by the City's Risk Manager. If you are responding to a solicitation and have questions regarding the insurance requirements, don't hesitate to get in touch with the City's Procurement and Contracts Department at (954) 786-4098. If the agreement/contract has already been awarded, please direct any inquiries and proof of the requisite

insurance coverage to City staff responsible for oversight of the subject project/contract.

The contractor/Consultant is responsible for delivering to the City for timely review and written approval/disapproval Certificates of Insurance, which evidence that all insurance required hereunder is in full force and effect and which name the city as an additional insured on a primary basis on all such coverage.

Throughout the term of this agreement/contract, the City, by and through its Risk Manager, reserves the right to review, modify, reject, or accept any insurance policies required by this agreement/contract, including limits, coverages, or endorsements. The City reserves the right, but not the obligation, to review and reject any insurer providing coverage because of poor financial condition or failure to operate legally.

Failure to maintain the required insurance shall be considered an event of default. The requirements herein, as well as the City review or acceptance of insurance maintained by the contractor/consultant, are not intended to and shall not in any way limit or qualify the liabilities and obligations assumed by the contractor/consultant under this agreement/contract.

Throughout the term of this agreement/contract, the contractor/consultant and all sub-contractors/sub-consultants or other agents hereunder shall, at their sole expense, maintain in full force and effect, the following insurance coverages and limits described herein, including endorsements:

1. Worker’s Compensation Insurance covering all employees and providing benefits as required by Florida Statute, Chapter 440. The contractor/consultant further agrees to be responsible for the employment, control, and conduct of its employees and any injury sustained by such employees during their employment.
2. Liability Insurance.
  - (a) Naming the City of Pompano Beach as an additional insured as the City’s interests may appear, on General Liability Insurance only, relative to claims which arise from the firm’s negligent acts or omissions in connection with contractor/consultant’s performance under this agreement/contract.
  - (b) Such Liability insurance shall include the following checked types of insurance and indicated minimum policy limits.

**Type of Insurance**

**Limits of Liability**

**GENERAL LIABILITY:** Minimum \$1,000,000 Per Occurrence and \$2,000,000 Per Aggregate

\* Policy to be written on a claim incurred basis

X comprehensive form X X premises - operations X explosion & collapse hazard	bodily injury and property damage  bodily injury and property damage
---	--

	underground hazard	
X	products/completed	bodily injury and property damage
X		combined
	operations hazard	
X	contractual insurance	bodily injury and property damage
X		combined
X	broad form property	bodily injury and property damage
X	damage	combined
X	independent contractors'	personal injury
X		
X	personal injury	
X		
	sexual abuse/molestation	Minimum \$1,000,000 Per Occurrence
—		and
		Aggregate
—	liquor legal liability	Minimum \$1,000,000 Per Occurrence and Aggregate

**AUTOMOBILE LIABILITY:** Minimum \$1,000,000 Per Occurrence and Aggregate.  
 Bodily injury (each person) bodily injury (each accident), Property damage, bodily injury and property damage combined.

- XX comprehensive form
- XX owned
- XX hired
- XX non-owned

**REAL & PERSONAL PROPERTY**

— comprehensive form Agent must show proof they have this coverage.

<b>EXCESS LIABILITY</b>		Per Occurrence	Aggregate
— other than umbrella	bodily injury and property damage combined	\$1,000,000	\$1,000,000

**PROFESSIONAL LIABILITY** Per Occurrence Aggregate

XX \* Policy to be written on a claims made basis \$1,000,000 \$1,000,000

(c) If Professional Liability insurance is required, the Consultant agrees the indemnification and hold harmless provisions set forth in the agreement/contract shall survive the termination or expiration of the agreement/contract for a period of four (4) years unless terminated sooner by the applicable statute of limitations.

<b>CYBER LIABILITY</b>		Per Occurrence	Aggregate
___	* Policy to be written on a claims made basis	\$1,000,000	\$1,000,000
<u>XX</u>	Network Security / Privacy Liability		
___	Breach Response / Notification Sublimit (minimum limit of 50% of policy aggregate)		
___	Technology Products E&O - \$1,000,000 (only applicable for vendors supplying technology related services and or products)		
___	Coverage shall be maintained in effect during the period of the agreement/contract and for not less than four (4) years after termination/ completion of the agreement/contract.		

3. Employer's Liability. If required by law, the Consultant and all sub-subcontractors/sub-consultants shall, for the benefit of their employees, provide, carry, maintain, and pay for Employer's Liability Insurance in the minimum amount of One Hundred Thousand Dollars (\$100,000.00) per employee, Five Hundred Thousand Dollars (\$500,000) per aggregate.

4. Policies: Whenever, under the provisions of this agreement/contract, insurance is required of the Awarded Firm, the Awarded Firm shall promptly provide the following:

- (a) Certificates of Insurance evidencing the required coverage;
- (b) Names and addresses of companies providing coverage;
- (c) Effective and expiration dates of policies; and
- (d) A provision in all policies affording thirty (30) days' written notice by a carrier of any cancellation or material change in any policy.

5. Insurance Cancellation or Modification. Should any required insurance policies be canceled before the expiration date or modified or substantially modified, the issuing company/firm shall provide thirty (30) days' written notice to the City.

6. Waiver of Subrogation. The awarded company/firm waives any and all rights of subrogation against the City, its officers, employees, and agents for each required policy. When required by the insurer, or should a policy condition not permit an insured to enter into a pre-loss agreement/contract to waive subrogation without an endorsement, then the awarded company/firm shall notify the insurer and request the policy be endorsed with a Waiver of Transfer of Rights of Recovery Against Others, or its equivalent. This Waiver of Subrogation requirement shall not apply to any policy that includes a condition to the policy not specifically prohibiting such an endorsement or voids coverage should the Awarded Firm enter into such an agreement/contract on a pre-loss basis.

### **I. Selection/Evaluation Process**

A Selection/Evaluation Committee (Committee) will be appointed to select the most qualified company(ies)/firm(s). The Committee will present its findings to the City Commission. The City Manager will approve a selection evaluation committee to assist in evaluating the Letter of Interest(s) received and to select the most qualified firm(s). All Letters of Interest will be evaluated by the Evaluation Committee and Procurement and Contracts staff based on the information submitted by the Submitting Firm(s) in response to this RLI. The Committee's findings will be presented to the City Commission.

Based upon the evaluation, the Evaluation Committee will recommend one Submitting Firm to the City Commissioners for the award and execution of an Agreement.

Proposals will be evaluated using the following criteria:

<b>Line</b>	<b>Criteria</b>	<b>Points Range</b>
<b>1</b>	<b>Prior experience of the company/firm with projects of a similar size and Complexity within past seven years.:</b>	<b>0-40</b>
	a) Number of similar projects	
	b) Complexity of similar projects	
	c) References from past projects performed by the company/firm per HB-683	
	d) Litigation within the past five (5) years arising out of the company's/firm's performance (list, describe outcome)	
<b>2</b>	<b>Qualifications of personnel including sub-contractor/sub-consultants:</b>	<b>0-35</b>
	a) Organizational chart for project	
	b) Number of technical staff	
	c) Qualifications of technical staff:	
	d) Number of licensed staff	
	e) Education of staff	
	f) Experience of staff on similar projects	
<b>3</b>	<b>Proximity of the nearest office to the project location:</b>	<b>0-15</b>
	a) Location	
	b) Number of staff at the nearest office	
<b>4</b>	<b>Local Vendors Program Participation</b>	<b>0-10</b>
	<b>TOTAL</b>	<b>100</b>

**NOTE:**

Financial statements required as submittals to prequalify for a solicitation will be exempt from public disclosure; however, financial statements submitted to prequalify for a solicitation and not required by the City may be subject to public disclosure.

The City Commission has the authority to (including, but not limited to) approve the recommendation, reject the recommendation, and direct staff to re-advertise this solicitation or, review the responses themselves and/or request oral presentations and determine a ranking order that may be the same or different from what was originally presented to the City Commission.

**Tie Breaker:**

In case there is a tie for the highest-ranked firms, the recommendations shall be made by giving preference to the following items in this order:

- 1) Maintenance of a Drug-Free Workplace in accordance with the requirements of 287.087, F.S.
- 2) Local Vendor Program Participation
- 3) Coin Toss

**Technicalities:**

Failure to respond, provide detailed information, or provide requested proposal elements may reduce points in the evaluation process. The Committee may recommend rejecting any Letter of Interest containing material deviations from the RLI. The Committee may recommend waiving any irregularities and technicalities. If only one (1) responsive proposal is received, the Committee will proceed without scoring the one (1) responsive statement received and may recommend that Procurement and Contracts Department staff negotiate the best terms and conditions with that sole firm, or may recommend rejecting the proposal.

**Committee's Recommendations:**

The Evaluation Committee may recommend rejecting the Letter of Interest received or awarding the contract. A complete recording shall be made of each meeting (evaluation and negotiation session) conducted by the Committee by the Purchasing Agent. The Committee may choose to conduct one (1) or more exempt negotiation sessions with as many ranked responsive firms, in its sole judgment, as it deems appropriate before making its recommendation for award, starting with the highest-ranked firm first, then the second highest-ranked firm, and so on. The Committee also has the discretion to recommend negotiations with only a single responsive firm if the Committee chooses to do so. During any such negotiations, the City staff assigned to negotiate reserves the right to negotiate any term, condition, or specification during an exempt negotiation session with the highest-ranked responsive firm.

**Determination of Award:**

The City Commission shall consider the Committee's award recommendation for this RLI and may approve such a recommendation. The City Commission may also, at its option, reject the Evaluation Committee's recommendation, or it may also reject all statements received, in which case the City may choose to re-advertise this solicitation "as is" or by adopting a modified version.

**J. Hold Harmless and Indemnification**

Firm covenants and agrees that it will indemnify hold harmless the City, its officials, employees, volunteers and other authorized agents from and against any and all claims, demands, suits, damages, attorneys' fees, fines, losses, penalties, defense costs or liabilities suffered by the City to the extent caused by any negligent act,

omission, breach, recklessness or misconduct of Consultant and/or any of its agents, officers, or employees hereunder, including any inaccuracy in or breach of any of the representations, warranties or covenants made by the Consultant, its agents, officers and/or employees, in the performance of services of this agreement/contract. To the extent considered necessary by City, any sums due Consultant hereunder may be retained by City until all of City's claims for indemnification hereunder have been settled or otherwise resolved, and any amount withheld shall not be subject to payment or interest by City.

**K. Right to Audit**

Awarded company's/firm's records which shall include but not be limited to accounting records, written policies and procedures, computer records, disks and software, videos, photographs, sub-contract/sub-consultants files (including proposals of successful and unsuccessful firms), originals estimates, estimating worksheets, correspondence, change order files (including documentation covering negotiated settlements), and any other supporting evidence necessary to substantiate charges related to the agreement/contract (all the foregoing hereinafter referred to as "records") shall be open to inspection and subject to audit and/or reproduction, during regular working hours, by City's agent or its authorized representative to the extent necessary to adequately permit evaluation and verification of any invoices, payments or claims submitted by the Awarded Firm or any of its payees pursuant to the execution of the agreement/contract. Such records subject to the examination shall also include but are not limited to, those necessary to evaluate and verify direct and indirect costs (including overhead allocations) as they may apply to costs associated with the agreement/contract.

For the purpose of such audits, inspections, examinations, and evaluations, the City's agent or authorized representative shall have access to said records from the effective date of the agreement/contract, for the duration of the service, and until five (5) years after the date of final payment by the City to awarded company/firm pursuant to the agreement/contract.

The City agent or its authorized representative shall have access to the awarded company's/firm's facilities, all necessary records, and adequate and appropriate workspace to conduct audits in compliance with this article. The City agent or authorized representative shall give auditees reasonable advance notice of intended audits.

The awarded company/firm shall require all sub-contractors/sub-consultants, insurance agents, and material suppliers (payees) to comply with this article's provisions by inserting the requirements in any written agreement/contract. Failure to obtain such written agreements/contracts that include such provisions shall be reason to exclude some or all of the related payees' costs from amounts payable to the contractor/consultant pursuant to the agreement/contract.

**L. Retention of Records and Right to Access**

The City is a public agency subject to Florida Statutes Chapter 119. The awarded company/firm shall comply with Florida's Public Records Law, as amended. Specifically, the awarded company/firm shall:

1. Keep and maintain public records required by the City in order to perform the service;
2. Upon request from the City's custodian of public records, provide the City with a copy of the requested records or allow the records to be inspected or copied within a reasonable time at a cost that does not exceed the cost provided in Florida Statutes Chapter 119, or as otherwise provided by law;
3. Ensure that public records that are exempt or confidential and exempt from public record are maintained.
4. Requirements are not disclosed except as authorized by law;
5. Ensure that public records that are exempt or confidential and exempt from public records disclosure

requirements are not disclosed except as authorized by law for the duration of the agreement/contract term and following completion of the agreement/contract if the awarded company/firm does not transfer the records to the City; and

6. Upon completion of the agreement/contract, transfer all public records in possession of the awarded company/firm at no cost to the City, or keep and maintain public records required by the City to perform the service. If the awarded company/firm transfers all public records to the City upon completion of the agreement/contract, the awarded company/firm shall destroy any duplicate public records that are exempt or confidential and exempt from public records disclosure requirements. If the awarded company/firm keeps and maintains public records upon completion of the agreement/contract, the awarded company/firm shall meet all applicable requirements for retaining public records. All records stored electronically must be provided to the City, upon request from the City's custodian of public records, in a format compatible with the City's information technology systems.

#### **M. Communications**

No negotiations, decisions, or actions shall be initiated or executed by the company/firm as a result of any discussions with any City employee. Only those communications in writing from the City may be considered duly authorized expressions on behalf of the City. In addition, only communications that are in writing from an authorized representative of the company/firm will be recognized by the City as duly authorized expressions on behalf of the respective company/firm.

#### **N. No Discrimination**

No discrimination shall be made on the basis of race, sex, color, age, religion, or national origin in the operations conducted under any agreement/contract with the City.

#### **O. Independent Contractor**

The awarded company/firm will conduct business as an independent contractor/consultant under the terms of the agreement/contract. Personnel services provided by the awarded company/firm shall be provided by employees of the awarded company/firm and subject to supervision by the awarded company/firm, and not as City officers, employees, or agents. Personnel policies, tax responsibilities, social security and health insurance, employee benefits, purchasing policies, and other similar administrative procedures applicable to services rendered under the agreement/contract shall be those of the awarded company/firm.

#### **P. Staff Assignment**

The City of Pompano Beach reserves the right to approve or reject, for any reason, Firm's staff assigned to this project at any time. Background checks may be required.

#### **Q. Agreement/Contract Terms**

The agreement/contract resulting from this solicitation shall include, but not be limited to, the following terms:

- The agreement/contract shall include, at a minimum, the entirety of this solicitation and the awarded proposal. The City of Pompano Beach City Attorney shall prepare it.
- If the City defends any claim, demand, cause of action, or lawsuit arising out of any act, action, negligent acts or negligent omissions, or willful misconduct of the contractor/consultant, its employees, agents, or servants during the performance of the agreement/contract, whether directly or indirectly, awarded The company/firm agrees to reimburse the City for all expenses, attorney's fees, and court costs incurred in defending such claim, cause of action, or lawsuit.

**R. Waiver**

It is agreed that no waiver or modification of the agreement/contract resulting from this solicitation or of any covenant, condition, or limitation contained in it shall be valid unless it is in writing and duly executed by the party to be charged with it. No evidence of any waiver or modification shall be offered or received in evidence in any proceeding, arbitration, or litigation between the parties arising out of or affecting the agreement/contract or the right or obligations of any party under it unless such waiver or modification is in writing, duly executed as previously provided. The parties agree that the provisions of this paragraph may not be waived except by a duly executed writing.

**S. Survivorship Rights**

The agreement/contract resulting from this solicitation shall be binding on and inure to the benefit of the respective parties and their executors, administrators, heirs, personal representatives, successors, and assigns.

**T. Manner of Performance**

Firm agrees to perform its duties and obligations under the agreement/contract resulting from this solicitation professionally and in accordance with all applicable local, federal, and state laws, rules, and regulations.

Firm agrees that the services provided under the agreement/contract resulting from this solicitation shall be provided by educated, trained, experienced, certified, and licensed employees in all areas encompassed within its designated duties. Firm agrees to furnish the City of Pompano Beach with all documentation, certification, authorization, license, permit, or registration currently required by applicable laws, rules, and regulations. Firm further certifies that it and its employees are now in and will maintain good standing with such governmental agencies and that it and its employees will keep all licenses, permits, registration, authorization, or certification required by applicable laws or regulations in full force and effect during the term of the agreement/contract. Failure of the Firm to comply with this paragraph shall constitute a material breach of the agreement/contract.

**U. Acceptance Period**

Proposals submitted in response to this solicitation must be valid for no less than one hundred and twenty (120) days from the closing date.

**V. Conditions and Provisions**

The completed proposal (together with all required attachments) must be submitted electronically to the City on or before the time and date as written herein. By electronically submitting a proposal, all firms shall agree to comply with all of this solicitation's conditions, requirements, and instructions as written or implied herein. All proposals and supporting materials submitted will become the property of the City.

Firm's response shall not contain any alteration to the document posted other than entering data in the spaces provided or including attachments as necessary. By submission of a response, Firm affirms that a complete set of solicitation documents was obtained from the eBid System only, and no alteration of any kind has been made to this solicitation. Exceptions or deviations to this proposal may not be added after the due date.

All firms are required to provide all information requested in this solicitation. Failure to do so may result in the proposal being disqualified.

The City reserves the right to postpone or cancel this solicitation or reject all proposals if, in its sole discretion, it deems it to be in the City's best interest to do so.

The City reserves the right to waive any technical or formal errors or omissions and to reject all proposals or to award an agreement/contract for the items herein, in part or whole, if it is determined to be in the City's best interests to do so.

The City shall not be liable for any costs incurred by the Firm in preparing proposals or for any work performed therein.

## **W. Standard Provisions**

### **1. Governing Law**

Any agreement/contract resulting from this solicitation shall be governed by the laws of the State of Florida, and the venue for any legal action relating to such agreement/contract will be in Broward County, Florida.

### **2. Licenses**

In order to perform public work, the awarded company/firm shall be licensed to do business in Florida, if an entity, and hold or obtain such Contractor and Business Licenses if required by State Statutes or local ordinances.

### **3. Conflict of Interest**

To determine any possible conflict of interest, each Firm must disclose if any Elected Official, Appointed Official, or City Employee is also an owner, corporate officer, or an employee of the company/firm. Suppose any Elected Official, Appointed Official, or City Employee is an owner, corporate officer, or employee. In that case, the Firm must file a statement with the Broward County Supervisor of Elections pursuant to Florida Statute, Section 112.313.

### **4. Drug-Free Workplace**

The awarded company(s)/firm(s) will be required to verify that they will operate a "Drug-Free Workplace" as outlined in Florida Statute, Section 287.087.

### **5. Public Entity Crimes**

A person or affiliate who has been placed on the convicted vendor list following a conviction by a public entity crime may not submit a proposal on an agreement/contract to provide any goods or services to a public entity, may not submit a proposal on an agreement/contract with a public entity for the construction or repair of a public building or public work, may not submit proposals on leases of real property to public entity, may not be awarded or perform work as a contractor, supplier, sub-contractor, consultant or sub-consultant under agreement/contract with any public entity, and may not transact business with any public entity in excess of the threshold amount provided in Florida Statute, Section 287.017, for Category Two for a period of thirty-six (36) months from the date of being placed on the convicted vendor list.

### **6. Patent Fees, Royalties, And Licenses**

Suppose the awarded company/firm requires or desires to use any design, trademark, device, material, or process covered by letters patent or copyright. In that case, the awarded company/firm and his surety shall indemnify and hold harmless the City from any and all claims for infringement because of the use of any such patented design, device, trademark, copyright, material, or process in connection with the work agreed to be performed and shall indemnify the City from any cost, expense, royalty or damage which the City may be obligated to pay because of any infringement at any time during or after completion of the work.

### **7. Permits**

The Awarded Firm shall be responsible for obtaining all permits, licenses, certifications, etc., required by federal, state, county, and municipal laws, regulations, codes, and ordinances to perform the work required in these specifications and to conform to the requirements of said legislation.

8. Familiarity with Laws

It is assumed the selected company(ies)/firm(s) will be familiar with all federal, state, and local laws, ordinances, rules, and regulations that may affect/their services pursuant to this solicitation. Ignorance on the part of the company/firm will not relieve the company/firm from responsibility.

9. Withdrawal of Proposals

A company/firm may withdraw its proposal without prejudice, no later than the advertised deadline for submission of proposals by written communication to the Procurement and Contracts, 1190 N.E. 3rd Avenue, Building C, Pompano Beach, Florida 33060.

10. Composition of Project Team

Company(ies)/Firm(s) are required to commit that the principals and personnel named in the proposal will perform the services throughout the contractual term unless otherwise provided for by way of a negotiated agreement/contract or written amendment to same executed by both parties. No diversion or substitution of principals or personnel will be allowed unless a written request that sets forth the qualifications and experience of the proposed replacement(s) is submitted to and approved by the City in writing.

11. Invoicing/Payment

All invoices should be sent to the contract's user department. Per Florida Statutes, Chapter 218, payment will be made within forty-five (45) days after receipt of a proper invoice.

12. Public Records

- a. The City of Pompano Beach is a public agency subject to Florida Statutes, Section 119. The awarded company/firm shall comply with Florida's Public Records Law, as amended. Specifically, the Awarded Firm shall:
  - i. Keep and maintain public records required by the City in order to perform the service;
  - ii. Upon request from the City's custodian of public records, provide the City with a copy of the requested records or allow the records to be inspected or copied within a reasonable time at a cost that does not exceed the cost provided in Florida Statutes, Section 119, or as otherwise provided by law;
  - iii. Ensure that public records that are exempt or confidential and exempt from public records disclosure requirements are not disclosed except as authorized by law for the duration of the agreement/contract term and following completion of the agreement/contract if the awarded company/firm does not transfer the records to the City; and
  - iv. Upon completion of the agreement/contract, transfer all public records in possession of the awarded company/firm at no cost to the City, or keep and maintain public records required by the City to perform the service. If the awarded company/firm transfers all public records to the City upon completion of the agreement/contract, the awarded company/firm shall destroy any duplicate public records that are exempt or confidential and exempt from public records disclosure requirements. If the awarded company/firm keeps and maintains public records upon completion of the agreement/contract, the contractor/consultant shall meet all applicable requirements for retaining public records. All records stored electronically must be provided to the City, upon request from the City's custodian of public records, in a format compatible

- with the City's information technology systems.
- b. Failure of the contractor/consultant to provide the above-described public records to the City within a reasonable time may subject the contractor/consultant to penalties under Florida Statute Section 119.10, as amended.

## **PUBLIC RECORDS CUSTODIAN**

**IF THE CONTRACTOR/CONSULTANT HAS QUESTIONS REGARDING THE APPLICATION OF CHAPTER 119, FLORIDA STATUTES, TO THE CONTRACTOR'S/CONSULTANT'S DUTY TO PROVIDE PUBLIC RECORDS RELATING TO THIS AGREEMENT/CONTRACT, CONTACT THE CUSTODIAN OF PUBLIC RECORDS AT:**

**CITY CLERK**  
**100 W. Atlantic Blvd., Suite 253, Pompano Beach, Florida 33060**  
**Phone: (954) 786-4611**  
**[RecordsCustodian@copbfl.com](mailto:RecordsCustodian@copbfl.com)**

### **X. Questions, Communication, and Addendums**

All questions regarding this solicitation will be submitted using the Questions feature in the eBid System. Oral and other interpretations or clarifications will be without legal effect. Addendum/Addenda will be posted to this solicitation in the eBid System, and it is the firm's responsibility to obtain all addenda before submitting a response to this solicitation.

Issuing a written addendum or posting an answer in response to a question submitted using the Questions feature in the eBid System are the only official methods for interpretation, clarification, or additional information. If any addendum is issued to this solicitation, the addendum will be issued via the eBid System. Before submitting its response, each firm shall be responsible for contacting the City's Procurement and Contracts Department at (954) 786-4098 to determine if an addendum was issued and to make such an addendum a part of its proposal. Each addendum will be posted to the solicitation in the eBid System.

### **Y. Protest Procedures**

The Protest Procedures established within the Procurement and Contracts Procedures Manual and Section 120.57, Florida Statutes, must be followed to file a valid Protest to this solicitation. Protests concerning the proposed solicitation award must be filed in writing with the Procurement and Contracts Director to be considered. They may only be filed by bidders or firms whose solicitation or award may aggrieve. The initial protest must be addressed to the following:

**Director of Procurement and Contracts, City of Pompano Beach**  
**1010 N.E. 3rd Avenue, Pompano Beach, Florida 33060**

**END OF THE RLI**



**City of Pompano Beach  
Procurement and Contracts Department  
1010 N.E. 3rd Avenue  
Pompano Beach, Florida, 33060**

September 4, 2025

ADDENDUM #1

**RLI25-072 Water and Reuse Treatment Plant Projects - CCNA**

To Whom It May Concern,

Addendum #1 is posted on the City's eBid website: <http://pompanobeachfl.ionwave.net>. Acknowledge receipt of this Addendum using the Addendum Attribute on the Attributes tab in the eBid System.

Internal software settings have been adjusted to solve a technical issue.

The deadline for receiving written questions in the eBid System is **September 22, 2025, at 12:00:00 p.m. (local)**.

The deadline for accepting proposals in the eBid system is **October 1, 2025, at 2:00:00 p.m. (local)**.

The remainder of the solicitation is unchanged at this time.

Sincerely,

Jeffrey English,  
Purchasing Agent.

cc: website



**City of Pompano Beach  
Procurement and Contracts Department  
1010 N.E. 3rd Avenue  
Pompano Beach, Florida, 33060**

September 8, 2025

ADDENDUM #2

**RLI25-072 Water and Reuse Treatment Plant Projects - CCNA**

To Whom It May Concern,

Addendum #2 is posted on the City's eBid website: <http://pompanobeachfl.ionwave.net>. Acknowledge receipt of this Addendum using the Addendum Attribute on the Attributes tab in the eBid System.

All documents for this solicitation have been updated to allow access to the public.

The deadline for receiving written questions in the eBid System is **September 22, 2025, at 12:00:00 p.m. (local)**.

The deadline for accepting proposals in the eBid system is **October 1, 2025, at 2:00:00 p.m. (local)**.

The remainder of the solicitation is unchanged at this time.

Sincerely,

Jeffrey English,  
Purchasing Agent.

cc: website



**City of Pompano Beach  
Procurement and Contracts Department  
1010 N.E. 3rd Avenue  
Pompano Beach, Florida, 33060**

October 1, 2025

ADDENDUM #3

**RLI25-072 Water and Reuse Treatment Plant Projects - CCNA**

To Whom It May Concern,

Addendum #3 is posted on the City's eBid website: <http://pompanobeachfl.ionwave.net>. Acknowledge receipt of this Addendum using the Addendum Attribute on the Attributes tab in the eBid System.

The link to a recording of the pre-proposal meeting is as follows:

[https://copb-purchasing.s3.us-east-1.amazonaws.com/RLI25-072\\_Water+and+Reuse+Treatment+Plant+Projects++CCNA/Pre-Proposal+Meeting+for+RLI25-072+Water+and+Reuse+Treatment+Plant+Projects+\(CCNA\).mp4](https://copb-purchasing.s3.us-east-1.amazonaws.com/RLI25-072_Water+and+Reuse+Treatment+Plant+Projects++CCNA/Pre-Proposal+Meeting+for+RLI25-072+Water+and+Reuse+Treatment+Plant+Projects+(CCNA).mp4)

RLI25-072\_meeting\_saved\_chat.txt, which contains the meeting's participants, has been uploaded to the Attachments tab of the City's eBid System.

The Addendum-2 notice has been uploaded to the Attachments tab of the City's eBid System.

The deadline for receiving written questions in the eBid System has passed.

The deadline for accepting proposals in the eBid system is **October 1, 2025, at 2:00:00 p.m. (local)**.

The remainder of the solicitation is unchanged at this time.

Sincerely,

Jeffrey English,  
Purchasing Agent.

cc: website



**City of Pompano Beach  
Procurement and Contracts Department  
1010 N.E. 3rd Avenue  
Pompano Beach, Florida, 33060**

October 1, 2025

ADDENDUM #4

**RLI25-072 Water and Reuse Treatment Plant Projects - CCNA**

To Whom It May Concern,

Addendum #4 is posted on the City's eBid website: <http://pompanobeachfl.ionwave.net>. Acknowledge receipt of this Addendum using the Addendum Attribute on the Attributes tab in the eBid System.

The deadline for receiving written questions in the eBid System has passed.

The deadline for accepting proposals in the eBid system has been extended to **October 8, 2025, at 2:00:00 p.m. (local)**.

The remainder of the solicitation is unchanged at this time.

Sincerely,

Jeffrey English,  
Purchasing Agent.

cc: website



**City of Pompano Beach  
Procurement and Contracts Department  
1010 N.E. 3rd Avenue  
Pompano Beach, Florida, 33060**

October 2, 2025

**ADDENDUM #5**

**RLI25-072 Water and Reuse Treatment Plant Projects - CCNA**

To Whom It May Concern,

Addendum #5 is posted on the City's eBid website: <http://pompanobeachfl.ionwave.net>. Acknowledge receipt of this Addendum using the Addendum Attribute on the Attributes tab in the eBid System.

The deadline for accepting questions has been extended to **October 7, 2025, at 12:00 p.m. (local)**

The deadline for accepting proposals in the eBid system is **October 15, 2025, at 2:00:00 p.m. (local)**.

The remainder of the solicitation is unchanged at this time.

Sincerely,

Jeffrey English,  
Purchasing Agent.

cc: website



## RLI25-072 Addendum 5

### McCafferty Brinson Consulting, LLC

### Supplier Response

#### Event Information

Number: RLI25-072 Addendum 5  
Title: Water and Reuse Treatment Plant Projects - CCNA  
Type: Request for Letters of Interest  
Issue Date: 8/28/2025  
Deadline: 10/15/2025 02:00 PM (ET)  
Notes: Pursuant to Section 287.055, Florida Statutes Consultant's Competitive Negotiation Act (CCNA), the City of Pompano Beach (the "City") invites professional companies/firms to submit a Letter of Interest (RLI) to provide engineering services at the Pompano Beach Water Treatment Plant on a continuing as-needed basis.

The selected firm shall demonstrate specific experience and capabilities and must have qualified personnel and expertise in the specified disciplines.

This RLI is subject to the "Cone of Silence," which imposes certain restrictions on communications concerning the RLI process.

The Cone of Silence shall take effect once this solicitation is released to the General Public. Respondents to this solicitation or persons acting on their behalf may not contact, between the release of the solicitation and the end of the 72 hours following the agency posting the notice of intended award, excluding Saturdays, Sundays, and state holidays, any employee or officer of the executive or legislative branch concerning any aspect of this solicitation, except in writing to the

## McCafferty Brinson Consulting, LLC Information

Address: 633 S. Andrews Ave.  
Suite 402  
Fort Lauderdale, FL 33301  
Phone: (954) 797-7100  
Web Address: mccaffertybrinson.com

By submitting this Response I affirm I have received, read and agree to the all terms and conditions as set forth herein. I hereby recognize and agree that upon execution by an authorized officer of the City of Pompano Beach, this Response, together with all documents prepared by or on behalf of the City of Pompano Beach for this solicitation, and the resulting Contract shall become a binding agreement between the parties for the products and services to be provided in accordance with the terms and conditions set forth herein. I further affirm that all information and documentation contained within this response to be true and correct, and that I have the legal authority to submit this response on behalf of the named Supplier (Offeror).

Audra McCafferty

*Signature*

*Submitted at 9/30/2025 09:39:55 AM (ET)*

amccafferty@mccaffertybrinson.com

*Email*

## Requested Attachments

### Letter of Interest

Letter of Transmittal.pdf

The electronic version of the Letter of Interest must be uploaded to the Response Attachments tab. Section G of the RLI includes the submittal requirements. Firm shall upload the response as one (1) file to the eBid System. The file size for uploads is limited to 250 MB. If the file size exceeds 10 MB, the response must be split and uploaded as two (2) separate files.

### Tier 1/ Tier 2 Local Business Form

T1\_T2\_Form.pdf

To comply with the City's Local Business Program as a Tier-1 or Tier-2 vendor, you must complete the Tier 1/ Tier 2 Local Business form from the attachments tab and upload it here.

### Proposer Information Page Form

Proposer Information Page Form.pdf

Proposer Information Page

### Qualification of Bidders Form

Qualifications Of Bidders Form.pdf

Qualification of Bidders Form from the attachments tab must be completed and uploaded to this tab.

### Local Business Program Forms

Local Business Program Forms.pdf

Local Business Program Forms (A, B, C, and D) from the attachments tab must be completed and uploaded to this tab.

### Project Team Form

Project Team Form.pdf

Submit a completed "Project Team" form. This form aims to identify the proposed team's key members, including any specialty subconsultants.

### W9 Request for Taxpayer Identification Number and Certification

W9 2024.pdf

## Response Attachments

### MBC Financial Statements.pdf

MBC Financial Statements - Confidential

**MBC 25-072 Response 10 01 25.pdf**

McCafferty Brinson Consulting, LLC 25-072 Response 10 01 25

**Bid Attributes****1 Local Business**

Is your company a Local Business located within the City of Pompano Beach City Limits as required by the Local Business Program? (A copy of your current City of Pompano Beach Business Tax Receipt may be requested.)

**2 Local Business Participation Percentage**

If you have indicated local business participation on the Local Business Participation Form Exhibit A enter the percentage of the contract that will be performed by local Pompano Beach businesses.

**3 Drug-Free Workplace**

STATEMENT UNDER SECTION 287.087, FLORIDA STATUTES ON DRUG-FREE WORKPLACE  
**REQUESTED INFORMATION BELOW IS ON THE ATTRIBUTES TAB FOR THE RFP IN THE EBID SYSTEM.  
 PROVIDE THIS INFORMATION ELECTRONICALLY.**

Preference must be given to Contractors submitting certification with their bid or proposal, certifying they have a drug-free workplace in accordance with Section 287.087, Florida Statutes. This requirement affects all public entities of the State and becomes effective January 1, 1991.

Preference shall be given to businesses with drug-free workplace programs. Whenever two or more bids which are equal with respect to price, quality and service are received by the State or by any political subdivision for the procurement of commodities or contractual services, a bid received from a business that certifies that it has implemented a drug-free workplace program shall be given preference in the award process. Established procedures for processing tie bids will be followed if none of the tied vendors have a drug-free workplace program. In order to have a drug-free workplace program, a business shall:

- (1) Publish a statement notifying employees that the unlawful manufacture, distribution, dispensing, possession, or use of a controlled substance is prohibited in the workplace and specifying the actions that will be taken against employees for violations of such prohibition.
  - (2) Inform employees about the dangers of drug abuse in the workplace, the business's policy of maintaining a drug-free workplace, any available drug counseling, rehabilitation and employee assistance programs, and the penalties that may be imposed upon employees for drug abuse violations.
  - (3) Give each employee engaged in providing the commodities or contractual services that are under bid, a copy of the statement specified in subsection (1).
  - (4) In the statement specified in subsection (1) notify the employees that as a condition of working on the commodities or contractual services that are under bid, the employee will abide by the terms of the statement and will notify the employer of any conviction of, or plea of guilty or nolo contendere to, any violation of Chapter 893 or of any controlled substance law of the United States or any state, for a violation occurring in the workplace, no later than five (5) days after such conviction.
  - (5) Impose a sanction on, or require the satisfactory participation in, a drug abuse assistance or rehabilitation program if such is available in the employee's community, by an employee who is so convicted.
  - (6) Make a good faith effort to continue to maintain a drug-free workplace through implementation of this section.
- As the person authorized to sign this statement, I certify that his company/firm complies with the above requirements.

By choosing YES, I hereby certify that the company/firm complies with all the above requirements

**4 Conflict of Interest**

For purposes of determining any possible conflict of interest, all bidders must disclose if any City of Pompano Beach employee is also an owner, corporate officer, or employee of their business. Indicate either "Yes" (a City employee is also associated with your business), or "No". (Note: If answer is "Yes", you must file a statement with the Supervisor of Elections, pursuant to Florida Statutes 112.313.) Indicate Yes or No below with the drop down menu.

**5 Vendor Certification Regarding Scrutinized Companies Lists (Any Dollar Amount)**

Section 215.4725, Florida Statutes, prohibits agencies from contracting (at any dollar amount) with companies on the Scrutinized Companies that Boycott Israel List, or with companies that are engaged in a boycott of Israel. As the person authorized to electronically sign on behalf of Respondent, I hereby certify by selecting the box below that the company responding to this solicitation is not listed on the Scrutinized Companies that Boycott Israel List. I also certify that the company responding to this solicitation is not participating in a boycott of Israel, and is not engaged in business operations in Syria or Cuba. I understand that pursuant to sections 287.135 and 215.4725, Florida Statutes, the submission of a false certification may subject company to civil penalties, attorney's fees, and/or costs.

 Certified**6 Terms & Conditions**

Check the box indicating you agree to the terms and conditions of this solicitation.

 Agree**7 Acknowledgement of Addenda**

Check this box to acknowledge that you have reviewed all addenda issued for this solicitation.

 Yes



[Department of State](#) / [Division of Corporations](#) / [Search Records](#) / [Search by Entity Name](#) /

## Detail by Entity Name

Florida Limited Liability Company  
 MCCAFFERTY BRINSON CONSULTING, LLC

**Filing Information**

**Document Number** L06000020660  
**FEI/EIN Number** 20-4382371  
**Date Filed** 02/24/2006  
**State** FL  
**Status** ACTIVE

**Principal Address**

633 S. ANDREWS AVE  
 SUITE 402  
 FORT LAUDERDALE, FL 33301

Changed: 01/10/2014

**Mailing Address**

633 S. ANDREWS AVE  
 SUITE 402  
 FORT LAUDERDALE, FL 33301

Changed: 01/10/2014

**Registered Agent Name & Address**

MCCAFFERTY, AUDRA I  
 633 S Andrews Ave  
 Suite 402  
 FORT LAUDERDALE, FL 33301

Address Changed: 01/10/2014

**Authorized Person(s) Detail**

**Name & Address**

Title MGR

MCCAFFERTY, AUDRA I  
 633 S. ANDREWS AVE, SUITE 402  
 FORT LAUDERDALE, FL 33301

Title MGR

BRINSON, FRANK A  
 633 S Andrews Ave  
 Suite 402

Ft Lauderdale, FL 33301

**Annual Reports**

<b>Report Year</b>	<b>Filed Date</b>
2024	01/12/2024
2025	01/31/2025
2026	01/12/2026

**Document Images**

<a href="#">01/12/2026 -- ANNUAL REPORT</a>	View image in PDF format
<a href="#">01/31/2025 -- ANNUAL REPORT</a>	View image in PDF format
<a href="#">01/12/2024 -- ANNUAL REPORT</a>	View image in PDF format
<a href="#">01/04/2023 -- ANNUAL REPORT</a>	View image in PDF format
<a href="#">01/11/2022 -- ANNUAL REPORT</a>	View image in PDF format
<a href="#">01/06/2021 -- ANNUAL REPORT</a>	View image in PDF format
<a href="#">01/08/2020 -- ANNUAL REPORT</a>	View image in PDF format
<a href="#">01/15/2019 -- ANNUAL REPORT</a>	View image in PDF format
<a href="#">03/06/2018 -- ANNUAL REPORT</a>	View image in PDF format
<a href="#">01/10/2017 -- ANNUAL REPORT</a>	View image in PDF format
<a href="#">03/08/2016 -- ANNUAL REPORT</a>	View image in PDF format
<a href="#">01/07/2015 -- ANNUAL REPORT</a>	View image in PDF format
<a href="#">01/10/2014 -- ANNUAL REPORT</a>	View image in PDF format
<a href="#">01/17/2013 -- ANNUAL REPORT</a>	View image in PDF format
<a href="#">01/04/2012 -- ANNUAL REPORT</a>	View image in PDF format
<a href="#">04/14/2011 -- ANNUAL REPORT</a>	View image in PDF format
<a href="#">02/16/2010 -- ANNUAL REPORT</a>	View image in PDF format
<a href="#">03/23/2009 -- ANNUAL REPORT</a>	View image in PDF format
<a href="#">07/21/2008 -- ANNUAL REPORT</a>	View image in PDF format
<a href="#">01/12/2007 -- ANNUAL REPORT</a>	View image in PDF format
<a href="#">02/24/2006 -- Florida Limited Liability</a>	View image in PDF format

**Exhibit B – Cover Page**

- 1. Consultant's Response**
- 2. Local Business Forms**
- 3. Consultant's Proposal**
- 4. Consultant's Rate Sheet**



## RLI25-072 Addendum 5

### McCafferty Brinson Consulting, LLC

### Supplier Response

#### Event Information

Number: RLI25-072 Addendum 5  
Title: Water and Reuse Treatment Plant Projects - CCNA  
Type: Request for Letters of Interest  
Issue Date: 8/28/2025  
Deadline: 10/15/2025 02:00 PM (ET)  
Notes: Pursuant to Section 287.055, Florida Statutes Consultant's Competitive Negotiation Act (CCNA), the City of Pompano Beach (the "City") invites professional companies/firms to submit a Letter of Interest (RLI) to provide engineering services at the Pompano Beach Water Treatment Plant on a continuing as-needed basis.

The selected firm shall demonstrate specific experience and capabilities and must have qualified personnel and expertise in the specified disciplines.

This RLI is subject to the "Cone of Silence," which imposes certain restrictions on communications concerning the RLI process.

The Cone of Silence shall take effect once this solicitation is released to the General Public. Respondents to this solicitation or persons acting on their behalf may not contact, between the release of the solicitation and the end of the 72 hours following the agency posting the notice of intended award, excluding Saturdays, Sundays, and state holidays, any employee or officer of the executive or legislative branch concerning any aspect of this solicitation, except in writing to the

## McCafferty Brinson Consulting, LLC Information

Address: 633 S. Andrews Ave.  
Suite 402  
Fort Lauderdale, FL 33301  
Phone: (954) 797-7100  
Web Address: mccaffertybrinson.com

By submitting this Response I affirm I have received, read and agree to the all terms and conditions as set forth herein. I hereby recognize and agree that upon execution by an authorized officer of the City of Pompano Beach, this Response, together with all documents prepared by or on behalf of the City of Pompano Beach for this solicitation, and the resulting Contract shall become a binding agreement between the parties for the products and services to be provided in accordance with the terms and conditions set forth herein. I further affirm that all information and documentation contained within this response to be true and correct, and that I have the legal authority to submit this response on behalf of the named Supplier (Offeror).

Audra McCafferty

*Signature*

*Submitted at 9/30/2025 09:39:55 AM (ET)*

amccafferty@mccaffertybrinson.com

*Email*

## Requested Attachments

### Letter of Interest

Letter of Transmittal.pdf

The electronic version of the Letter of Interest must be uploaded to the Response Attachments tab. Section G of the RLI includes the submittal requirements. Firm shall upload the response as one (1) file to the eBid System. The file size for uploads is limited to 250 MB. If the file size exceeds 10 MB, the response must be split and uploaded as two (2) separate files.

### Tier 1/ Tier 2 Local Business Form

T1\_T2\_Form.pdf

To comply with the City's Local Business Program as a Tier-1 or Tier-2 vendor, you must complete the Tier 1/ Tier 2 Local Business form from the attachments tab and upload it here.

### Proposer Information Page Form

Proposer Information Page Form.pdf

Proposer Information Page

### Qualification of Bidders Form

Qualifications Of Bidders Form.pdf

Qualification of Bidders Form from the attachments tab must be completed and uploaded to this tab.

### Local Business Program Forms

Local Business Program Forms.pdf

Local Business Program Forms (A, B, C, and D) from the attachments tab must be completed and uploaded to this tab.

### Project Team Form

Project Team Form.pdf

Submit a completed "Project Team" form. This form aims to identify the proposed team's key members, including any specialty subconsultants.

### W9 Request for Taxpayer Identification Number and Certification

W9 2024.pdf

## Response Attachments

### MBC Financial Statements.pdf

MBC Financial Statements - Confidential

**MBC 25-072 Response 10 01 25.pdf**

McCafferty Brinson Consulting, LLC 25-072 Response 10 01 25

**Bid Attributes****1 Local Business**

Is your company a Local Business located within the City of Pompano Beach City Limits as required by the Local Business Program? (A copy of your current City of Pompano Beach Business Tax Receipt may be requested.)

**2 Local Business Participation Percentage**

If you have indicated local business participation on the Local Business Participation Form Exhibit A enter the percentage of the contract that will be performed by local Pompano Beach businesses.

**3 Drug-Free Workplace**

STATEMENT UNDER SECTION 287.087, FLORIDA STATUTES ON DRUG-FREE WORKPLACE  
**REQUESTED INFORMATION BELOW IS ON THE ATTRIBUTES TAB FOR THE RFP IN THE EBID SYSTEM.  
 PROVIDE THIS INFORMATION ELECTRONICALLY.**

Preference must be given to Contractors submitting certification with their bid or proposal, certifying they have a drug-free workplace in accordance with Section 287.087, Florida Statutes. This requirement affects all public entities of the State and becomes effective January 1, 1991.

Preference shall be given to businesses with drug-free workplace programs. Whenever two or more bids which are equal with respect to price, quality and service are received by the State or by any political subdivision for the procurement of commodities or contractual services, a bid received from a business that certifies that it has implemented a drug-free workplace program shall be given preference in the award process. Established procedures for processing tie bids will be followed if none of the tied vendors have a drug-free workplace program. In order to have a drug-free workplace program, a business shall:

- (1) Publish a statement notifying employees that the unlawful manufacture, distribution, dispensing, possession, or use of a controlled substance is prohibited in the workplace and specifying the actions that will be taken against employees for violations of such prohibition.
  - (2) Inform employees about the dangers of drug abuse in the workplace, the business's policy of maintaining a drug-free workplace, any available drug counseling, rehabilitation and employee assistance programs, and the penalties that may be imposed upon employees for drug abuse violations.
  - (3) Give each employee engaged in providing the commodities or contractual services that are under bid, a copy of the statement specified in subsection (1).
  - (4) In the statement specified in subsection (1) notify the employees that as a condition of working on the commodities or contractual services that are under bid, the employee will abide by the terms of the statement and will notify the employer of any conviction of, or plea of guilty or nolo contendere to, any violation of Chapter 893 or of any controlled substance law of the United States or any state, for a violation occurring in the workplace, no later than five (5) days after such conviction.
  - (5) Impose a sanction on, or require the satisfactory participation in, a drug abuse assistance or rehabilitation program if such is available in the employee's community, by an employee who is so convicted.
  - (6) Make a good faith effort to continue to maintain a drug-free workplace through implementation of this section.
- As the person authorized to sign this statement, I certify that his company/firm complies with the above requirements.

By choosing YES, I hereby certify that the company/firm complies with all the above requirements

**4 Conflict of Interest**

For purposes of determining any possible conflict of interest, all bidders must disclose if any City of Pompano Beach employee is also an owner, corporate officer, or employee of their business. Indicate either "Yes" (a City employee is also associated with your business), or "No". (Note: If answer is "Yes", you must file a statement with the Supervisor of Elections, pursuant to Florida Statutes 112.313.) Indicate Yes or No below with the drop down menu.

**5 Vendor Certification Regarding Scrutinized Companies Lists (Any Dollar Amount)**

Section 215.4725, Florida Statutes, prohibits agencies from contracting (at any dollar amount) with companies on the Scrutinized Companies that Boycott Israel List, or with companies that are engaged in a boycott of Israel. As the person authorized to electronically sign on behalf of Respondent, I hereby certify by selecting the box below that the company responding to this solicitation is not listed on the Scrutinized Companies that Boycott Israel List. I also certify that the company responding to this solicitation is not participating in a boycott of Israel, and is not engaged in business operations in Syria or Cuba. I understand that pursuant to sections 287.135 and 215.4725, Florida Statutes, the submission of a false certification may subject company to civil penalties, attorney's fees, and/or costs.

 Certified**6 Terms & Conditions**

Check the box indicating you agree to the terms and conditions of this solicitation.

 Agree**7 Acknowledgement of Addenda**

Check this box to acknowledge that you have reviewed all addenda issued for this solicitation.

 Yes

LOCAL BUSINESS EXHIBIT "A"  
 CITY OF POMPANO BEACH, FLORIDA  
 LOCAL BUSINESS PARTICIPATION FORM

Solicitation Number & Title: RLI 25-072 Water and Reuse Treatment Plant Projects - Continuing Contracts (CCNA) Prime Contractor's Name: McCafferty Brinson Consulting, LLC

Name of Firm, Address	Contact Person, Telephone Number	Type of Work to be Performed/Material to be Purchased	Contract Amount or %
Keith and Assoc., 301 E. Atlantic Blvd., Pompano Beach, FL 33060	Mark Mitchell, 954.788.3400	Surveying, Landscaping, and Subsurface Utility Engineering	12%*
QuEST Eng. Services and Testing, 2737 NW 19th St., Pompano Beach, FL 33069	R.N. Sailappan, 954.582.9800	Geotechnical Engineering and Specialty Testing	8%*
*Estimated percentage. Actual participation will be based upon specific scope in the work authorization.			

LOCAL BUSINESS EXHIBIT "A"



LOCAL BUSINESS EXHIBIT "B"  
LOCAL BUSINESS  
LETTER OF INTENT TO PERFORM AS A LOCAL SUBCONTRACTOR

Solicitation Number RLI 25-072

TO: McCafferty Brinson Consulting, LLC  
(Name of Prime or General Bidder)

The undersigned City of Pompano Beach business intends to perform subcontracting work in connection with the above contract as (check below)

an individual  a corporation  
 a partnership  a joint venture

The undersigned is prepared to perform the following work in connection with the above Contract, as hereafter described in detail:

QuEST will provide geotechnical engineering and specialty testing  
services to support MBC under the Continuing Services Contract for  
Water and Reuse Treatment Plant projects.

at the following price: To be determined based on work authorization for the contract.

9/18/2025  
(Date)

QuEST Engineering Services & Testing, Inc.  
(Print Name of Local Business Contractor)

2737 NW 19th Street  
(Street Address)

Pompano Beach, FL 33069  
(City, State Zip Code)

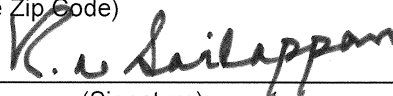
BY:   
(Signature)

**IMPORTANT NOTE:** Signatures on this form MUST be by an authorized employee of Subcontractor and must be uploaded to the Response Attachment Tab

LOCAL BUSINESS EXHIBIT "B"

**NOT APPLICABLE**

LOCAL BUSINESS EXHIBIT "C

LOCAL BUSINESS  
UNAVAILABILITY FORM

BID # \_\_\_\_\_

I, \_\_\_\_\_  
(Name and Title)

of \_\_\_\_\_, certify that on the \_\_\_\_\_ day of

\_\_\_\_\_, \_\_\_\_\_, I invited the following LOCAL BUSINESSES to bid work items to be performed in the City of Pompano Beach:

Business Name, Address	Work Items Sought	Form of Bid Sought (i.e., Unit Price, Materials/Labor, Labor Only, etc.)
_____	_____	_____
_____	_____	_____
_____	_____	_____
_____	_____	_____
_____	_____	_____

Said Local Businesses:

- \_\_\_ Did not bid in response to the invitation
- \_\_\_ Submitted a bid which was not the low responsible bid
- \_\_\_ Other: \_\_\_\_\_

Name and Title: \_\_\_\_\_

Date: \_\_\_\_\_

Note: Attach additional documents as available.

**NOT APPLICABLE**

LOCAL BUSINESS EXHIBIT "D"  
GOOD FAITH EFFORT REPORT  
LOCAL BUSINESS PARTICIPATION

BID # \_\_\_\_\_

1. What portions of the contract have you identified as Local Business opportunities?

\_\_\_\_\_  
\_\_\_\_\_  
\_\_\_\_\_  
\_\_\_\_\_

2. Did you provide adequate information to identified Local Businesses? Please comment on how you provided this information.

\_\_\_\_\_  
\_\_\_\_\_  
\_\_\_\_\_

3. Did you send written notices to Local Businesses?

\_\_\_\_ Yes      \_\_\_\_ No

If yes, please include copy of the notice and the list of individuals who were forwarded copies of the notices.

4. Did you advertise in local publications?

\_\_\_\_ Yes      \_\_\_\_ No

If yes, please attach copies of the ads, including name and dates of publication.

5. What type of efforts did you make to assist Local Businesses in contracting with you ?

\_\_\_\_\_  
\_\_\_\_\_

7. List the Local Businesses you will utilize and subcontract amount.

\_\_\_\_\_ \$ \_\_\_\_\_  
\_\_\_\_\_ \$ \_\_\_\_\_  
\_\_\_\_\_ \$ \_\_\_\_\_

8. Other comments: \_\_\_\_\_

\_\_\_\_\_

**COMPLETE THE PROJECT TEAM FORM ON THE ATTACHMENTS TAB IN THE EBID SYSTEM. PROPOSERS ARE TO COMPLETE FORM IN ITS ENTIRITY AND INCLUDE THE FORM IN YOUR PROPOSAL THAT MUST BE UPLOADED TO THE RESPONSE ATTACHMENTS TAB FOR THE RLI IN THE EBID SYSTEM.**

**PROJECT TEAM**

RLI NUMBER \_\_\_\_\_

Federal I.D.# \_\_\_\_\_

**PRIME**

Role	Name of Individual Assigned to Project	Number of Years Experience	Education, Degrees
Principal-In-Charge	_____	_____	_____
Project Manager	_____	_____	_____
Asst. Project Manager	_____	_____	_____
Other Key Member	_____	_____	_____
Other Key Member	_____	_____	_____

**SUB-CONSULTANT**

Role	Company Name and Address of Office Handling This Project	Name of Individual Assigned to the Project
Surveying	_____	_____
	_____	_____
Landscaping	_____	_____
	_____	_____
Engineering	_____	_____
	_____	_____
Other Key Member	_____	_____
	_____	_____
Other Key Member	_____	_____
	_____	_____
Other Key Member	_____	_____
	_____	_____
Other Key Member	_____	_____
	_____	_____

(use attachments if necessary)

LOCAL BUSINESS EXHIBIT "D" – Page 2

---

---

---



Bidder Company Name \_\_\_\_\_

**Qualifications Of Bidders**

To demonstrate qualifications to perform the work, and to be considered for award, each bidder shall submit at least three (3) business customer references. Provide information for business customers for whom you have performed work of this nature which you list as references, excluding the City of Pompano Beach. (Use an attachment if necessary.)

1. Name and address of customer: \_\_\_\_\_

\_\_\_\_\_

Contact person name, telephone number and email address: \_\_\_\_\_

\_\_\_\_\_

Description of services provided and date(s) of service: \_\_\_\_\_

\_\_\_\_\_

2. Name and address of customer: \_\_\_\_\_

\_\_\_\_\_

Contact person name, telephone number and email address: \_\_\_\_\_

\_\_\_\_\_

Description of services provided and date(s) of service: \_\_\_\_\_

\_\_\_\_\_

3. Name and address of customer: \_\_\_\_\_

\_\_\_\_\_

Contact person name, telephone number and email address: \_\_\_\_\_

\_\_\_\_\_

Description of services provided and date(s) of service: \_\_\_\_\_

\_\_\_\_\_

# City of Pompano Beach

## Water and Reuse Treatment Plant Projects - Continuing Contracts (CCNA)

RLI 25-072

October 1, 2025





October 1, 2025

The City of Pompano Beach

Submitted Electronically via Ionwave: <https://pompanobeachfl.ionwave.net>

**Subject: Letter of Interest, Water and Reuse Treatment Plant Projects - Continuing Contracts  
Request for Letters of Interest (RLI) 25-072**

To Whom it May Concern:

On behalf of our team, McCafferty Brinson Consulting, LLC (MBC) is pleased to submit this Letter of Interest (LOI) for continuing engineering services for water and reuse treatment plant projects to the City of Pompano Beach. MBC has served the City since 2010 under previous continuing contracts, and MBC principals have been involved in projects for the City since 2006. MBC's philosophy has always been to focus on providing the highest level of service to a relatively small number of select local clients, and to maintain long-term, personal client-service relationships. Our 20-year record of outstanding service to the City is a reflection of this philosophy.

We understand that the scope of services required under this contract includes not only design, bidding, and construction engineering for projects at the City's drinking water and reuse treatment plants, but also planning, studies, regulatory compliance, permitting, treatment process operations and optimization, as well as funding acquisition and compliance services.

MBC is proud to have partnered with the City since 2010 as a leading utility in South Florida in proactively planning and implementing improvements for meeting and exceeding drinking water quality regulations, providing the highest quality drinking water and reuse water services to the City's customers, in research and development of innovations in treatment process design and long-term process optimization, as well as identifying, securing, and maximizing outside grant and loan funding opportunities to cover project costs, reducing the financial burden on the City's rate-payers.

In 2014, MBC assisted the City in becoming one of the first utilities in South Florida to be certified as a "four-log virus treatment" drinking water facility, providing the highest regulatory level of disinfection of the City's drinking water supply, and substantially reducing the City's exposure to the risk of regulatory enforcement actions under the Federal Ground Water Rule (e.g., public notifications and/or boil water orders).

In 2017, MBC partnered with the City's engineering and operations staff at the drinking water treatment plant to design and construct a nanofiltration (NF) pilot plant in preparation for the City's most recent routine membrane element replacement. In addition to selecting and pre-qualifying the best membrane element selection for the City's NF facility, the City established an aggressive goal of completely eliminating sulfuric acid and antiscalant pretreatment in the City's NF process. With MBC's assistance, this effort was ultimately successful, and in 2020 the Pompano Beach NF facility became one of only two large NF facilities in Florida (and likely the country) to operate successfully with no chemical pretreatment. Since 2020, the City has realized over \$3 million in operating cost savings as a result of this achievement. Perhaps more importantly, it has created a safer working environment for plant operating staff and reduced liability exposure and regulatory burdens on the City by eliminating the need for operating staff to store and handle large quantities of hazardous sulfuric acid.

**McCafferty Brinson Consulting, LLC**

633 South Andrews Avenue, Suite 402, Fort Lauderdale, Florida 33301 • Telephone: 954.797.7100  
[www.mccaffertybrinson.com](http://www.mccaffertybrinson.com) • Florida Registry No. 26952

**McCafferty Brinson**  
*consulting*

October 1, 2025

Page 2

Although not explicitly mentioned in the RLI, one essential responsibility that we will continue to assume as the City's consultant under this contract is anticipating and assisting the City in planning for new regulations that may impact the City in the future. In 2022, MBC recognized the potential major impact to the City of the proposed National Primary Drinking Water Regulation (NPDWR) for per- and polyfluoroalkyl substances (PFAS). In February 2023, MBC notified the City of opportunities for grant funding for the necessary improvements to the City's water treatment plant under the Florida Department of Environmental Protection (FDEP) Drinking Water State Revolving Fund (DWSRF) Emerging Contaminants (EC) program. By August of 2023, MBC had assisted the City in securing \$9.595 million in grant funds for planning and design of improvements to comply with the PFAS NPDWR under the FDEP DWSRF EC program. In addition, by committing to and maintaining an extremely aggressive design schedule to meet critical funding milestones, MBC's design team, in cooperation with City staff, positioned the City to receive another \$46.2 million (\$11.6 million of which is 100% principal forgiveness) in funding for construction of the project. The City is currently on track to meet the compliance deadline for the PFAS NPDWR, while maximizing funding opportunities to reduce the need for future customer rate increases.

In preparation of this LOI, we have reviewed the City's 2026-2030 Utility Renewal and Replacement capital projects in detail to further familiarize ourselves with the City's needs and upcoming projects. Our submittal highlights our experience, expertise, and client-service commitment relative to these projects. In reviewing our submittal, you will find that we have a history of successful projects and satisfied South Florida clients. Leveraging our low overhead, intimate knowledge of your facilities, and match of experience and expertise to the City's needs, the MBC team is uniquely qualified to complete the City's scheduled capital improvement projects extremely cost-effectively, as well as assist the City in continuing to comply with changing regulations.

We have assembled a team that is not only highly qualified to meet the full range of services requested under this RLI, but is also familiar with the City's drinking water and reuse water treatment facilities. Our team is led by MBC as the prime firm (**our address and telephone number are provided at the bottom of this letterhead, and our Federal Tax Identification Number is 20-4382371, as requested in the RLI**). H2M Architects & Engineers, Inc. (H2M) will provide structural, architectural, and civil/stormwater engineering services. Hillers Electrical Engineering (HEE) will provide electrical and instrumentation and controls engineering support. Surveying, underground utility locating, and landscape architecture services will be provided by Keith & Associates, Inc. (KA), while Quest Engineering Services and Testing, Inc. (QuEST) will provide geotechnical engineering services. As you will see in reviewing our submittal, we have assembled our team to maximize participation to achieve the City's goals under the Local Business Program.

Although City staff are welcome to communicate with any member of our team at any time, I will serve as the City's primary contact for this submission and throughout this contract assignment. We would like to thank you for this opportunity to present our qualifications for this contract. We remain fully committed to providing outstanding service to the City under this contract and are eagerly looking forward to continuing our service to the City of Pompano Beach.

Sincerely,



Digitally signed by Frank A.  
Brinson, P.E.  
Date: 2025.09.19 15:42:40  
-04'00'

Frank A. Brinson, P.E.

Vice President

**McCafferty Brinson Consulting, LLC**

[fbrinson@mccaffertybrinson.com](mailto:fbrinson@mccaffertybrinson.com)



## Table of Contents

---

<b>Tab 1.</b>	Letter of Transmittal
<b>Tab 2.</b>	Technical Approach
<b>Tab 3.</b>	References
<b>Tab 4.</b>	Project Team Form
<b>Tab 5.</b>	Organizational Chart
<b>Tab 6.</b>	Statement of Skills and Experience of Project Team
<b>Tab 7.</b>	Resumes of Key Personnel
<b>Tab 8.</b>	Office Locations
<b>Tab 9.</b>	Litigation
<b>Tab 10.</b>	City Forms
<b>Tab 11.</b>	Reviewed and Audited Financial Statements
<b>Tab 12.</b>	Insurance

***Congratulations!***

**FSAWWA Region VI**

**BEST TASTING DRINKING  
WATER CONTEST 2025**

***City of Pompano Beach Wins!***

## 2. Technical Approach

### 2.1 Summary of Capital Improvement Program

The scope of work requested under this continuing services contract can be divided into two general categories: (1) design and construction administration assistance for the City's upcoming water and reuse water capital projects, and (2) engineering planning, studies, regulatory compliance, funding coordination, and general consulting associated with these two systems. These sectors of the engineering consulting industry represent MBC's core business. As mentioned in our transmittal letter, MBC specializes in serving South Florida utilities with "inside-the-fence" treatment process projects and process operations and optimization that require a high level of technical expertise. As a small, local firm, we have the ability to complete these projects very cost-effectively and expeditiously for our clients, without sacrificing quality or technical soundness.

In preparation of this proposal, we reviewed the City's 2026-2030 Utility Renewal & Replacement program to further familiarize ourselves with the City's scheduled projects and upcoming needs. The largest component of the City's 2026-2030 program is water treatment plant maintenance and improvements, at about 41% of the total utility budget. Drinking water treatment facility planning, design, construction, operations, and treatment process optimization constitute MBC's core business, with particular emphasis on nanofiltration (NF) membrane treatment such as the City utilizes at their water treatment plant. MBC has had an integral role in the development in recent years of the City's water treatment facility as a ground-breaking, landmark facility, from being one of the first facilities in South Florida to be certified by the Florida Department of Environmental Protection (FDEP) to provide four-log virus treatment, to more recently completely eliminating chemical pretreatment at the NF facility, saving operating costs and creating a safer workplace for the City's plant staff. Our local water treatment experience and expertise are ideally aligned with the City's water treatment needs under this contract.



Reuse treatment projects make up approximately 14% of the City's 2026-2030 program budget. MBC also has a long, successful history of assisting the City with maintaining and improving the City's reuse treatment plant. Similar to our water treatment project work for the City, our technical approach to reuse treatment projects leverages our detailed understanding of the City's facilities, and focuses on developing the right, tailored solutions for the City's reuse plant needs, as well as responsive and timely implementation of those solutions. As a prime example, one of MBC's first projects at the reuse treatment plant was to optimize the reuse filter backwash system, resulting in an annual cost savings of over \$100,000 and substantial backwash water savings. MBC assisted the City in implementation of the improvements by serving as the engineer of record for a design-build contract between the City and the filter manufacturer to modify the controls of the filter backwash system.



In 2018, MBC responded to an urgent request from the City for assistance in meeting reuse irrigation demands at the City’s golf course during a severe drought period. In less than 30 days from authorization to proceed from the City, MBC was able to complete the design and secure all necessary permits to implement a temporary potable water tank fill line for the City’s reuse storage tank to supplement the reuse water production and meet irrigation needs. Although both of these were relatively small projects, they demonstrate MBC’s commitment to responsive client service, as well as our local-firm agility and ability to respond quickly and effectively when unanticipated needs for engineering services arise.

**2.2 Non-Capital Engineering Consulting Needs**

In addition to engineering design, permitting, and construction contract administration for the City’s upcoming capital improvement projects, the City will have a need for “soft” engineering services such as for engineering planning, studies, and regulatory compliance, as well as funding acquisition and compliance. MBC has been involved in planning studies for municipal utilities ranging from utility master planning, hydraulic modeling of both potable water and wastewater systems, project financing, development of capital improvement programs, engineering bond reports, as well as regulation-mandated planning studies.

With these types of projects, it is critical that clear, explicitly defined goals and objectives are developed and agreed upon between the project team and the City during the scoping stage of the project. Without this, the project will lack clear direction, and the end work product is likely to miss the expectations of the City and be of little to no

long-term value to the City. Next, a specific plan of action and project schedule should be developed, and a project team identified. During execution of the project, the project manager must continuously monitor the schedule, budget, and quality of the work product. To ensure the end result meets the City’s goals and expectations for the project, clear and open communications must exist between the project team and the City. Perhaps most importantly, the City must have the opportunity to review work products at critical progress stages of the work and provide feedback to tailor the effort to the City’s needs.

MBC has demonstrated the success of our technical approach to long-term engineering planning for the City’s utility system, assisting the City in cost-effectively and efficiently navigating the changing regulatory environment through projects and studies such as the 2020 *Gravity Filter Refurbishment and Alternative Treatment Technology Study*, the 2021 *Nanofiltration Process Expansion Study*, and the 2024 *Emerging Contaminants Water Treatment Plant Upgrades Water Facility Plan*.

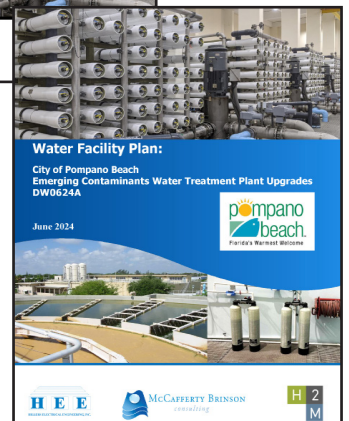
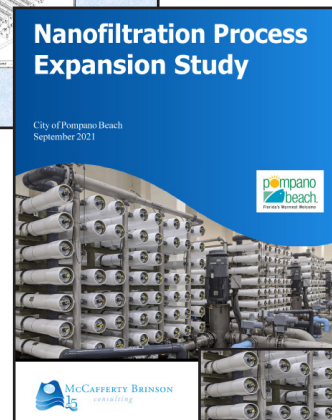

In addition to engineering planning, the City will have a need for regulatory compliance consulting to maintain continued compliance with changing water quality and operations-related regulations. As mentioned in our letter of transmittal, in 2022, MBC recognized the potential major impact to the City of the National Primary Drinking Water Regulation (NPDWR) for per- and polyfluoroalkyl substances (PFAS) proposed by the United States Environmental Protection Agency (USEPA). In February 2023, MBC notified the City of opportunities for grant funding for the necessary improvements to the City's water treatment plant under the Florida Department of Environmental Protection (FDEP) Drinking Water State Revolving Fund (DWSRF) Emerging Contaminants (EC) program. By August of 2023, MBC had assisted the City in securing \$9.595 million in grant funds for planning and design of improvements to comply with the PFAS NPDWR under the FDEP DWSRF EC program. In addition, by committing to and maintaining an extremely aggressive design schedule to meet critical funding milestones, MBC's design team, in cooperation with City staff, positioned the City to receive another \$46.2 million (\$11.6 million of which is 100% principal forgiveness) in funding for construction of the project. Additionally, the City's project was waitlisted for \$114 million for future SRF funding, to potentially be awarded in August 2026. The City is currently on track to meet the compliance deadline for the PFAS NPDWR, while maximizing funding opportunities to reduce the need for future customer rate increases.

MBC has a long history of facilitating and managing funding of City projects through multiple funding sources, including the FDEP SRF programs, DWSRF Emerging Contaminants program, as well as the Broward County Mobility Advancement (surtax) Program, and State of Florida appropriations. Over the years, MBC has collaborated with City staff to maximize opportunities to leverage innovative funding sources to implement numerous utility, stormwater, and transportation projects. Notable achievements resulting from this collaboration include:

- Procured nearly \$100 million in outside funding for City projects since 2017.
- Procured over \$26 million in grants and principal forgiveness for City projects.
- First in the State of Florida to finalize a loan agreement under the FDEP DWSRF Emerging Contaminants program (\$9.595 million 100% principal forgiveness for planning and design of the City's WTP PFAS project).
- Procured \$46.2 million in construction funding for the City's WTP PFAS improvements project.



## 2.3 Design and Construction Projects

MBC's approach to design and construction projects focuses on three fundamental elements: schedule, cost, and quality control. These are the essential components of good project management, whether the project is a small, single-discipline, short-term project, or a large, complex, multi-million-dollar project executed over a period of several years. Most of the individual projects that the City has scheduled in the 2026-2030 program have a total value of \$3 million or less. While MBC's principals have abundant experience in managing large, complex projects, it is critical to recognize the equal importance of schedule, cost, and quality control on smaller projects.

### 2.3.1 Schedule Control

In the regulatory environment, schedule control can make the difference between a utility consistently exceeding regulatory requirements and staying in compliance with rapidly changing regulations on one hand, and fines for violations on the other. In this context, "schedule control" involves continuously monitoring and anticipating changing regulatory demands, advance planning, developing and maintaining resources and scheduling tools, and timely implementation of compliance-related improvements. MBC understands and appreciates the importance of timely compliance with regulatory requirements to a municipality and public utility.

In the design and construction environment, schedule control has a direct impact on cost to the Owner. Delays in design not only increase design costs, but also construction costs through extended interest on project funding, material

and equipment cost escalation, and general construction market variability. During construction, delays nearly always result in a direct and/or indirect increase in cost to the Owner. MBC recognizes that it is critical to the success of any project that a realistic schedule be developed at the inception of the project, that "buy-in" and commitment to the schedule is obtained from all major project stakeholders, and that the schedule is continually updated and monitored through the life of the project to avoid these cost increases. The schedule must identify all major tasks and their interdependency relationships. MBC leverages a range of experience, expertise, scheduling software, and other tools to develop realistic project schedules, track progress during the project, and maintain the schedule through completion of the project. We have a strong track record in bringing projects in on or ahead of schedule. As an example, the single largest design and "construction" project that MBC has completed for the City under our current contract is the NF membrane replacement project presented in Section 6.4 (\$1,098,000). This project was completed well ahead of the original contract schedule and with no change orders.

### 2.3.2 Cost Control

MBC also has a strong track record in cost control in our recent projects. This stems from thorough planning at the inception of the project in developing the engineering budget and identifying project tasks and requirements, assembling and committing a qualified project team, and recognizing and controlling major influences on costs through the life of the project. To avoid surprises, it is critical that a detailed plan for project execution be developed at the earliest stage. The plan must identify and commit a qualified project team, with clear and non-overlapping divisions of responsibility.

Conceptual Project Timeline to Maximize EC Funding Opportunity (Phase I)

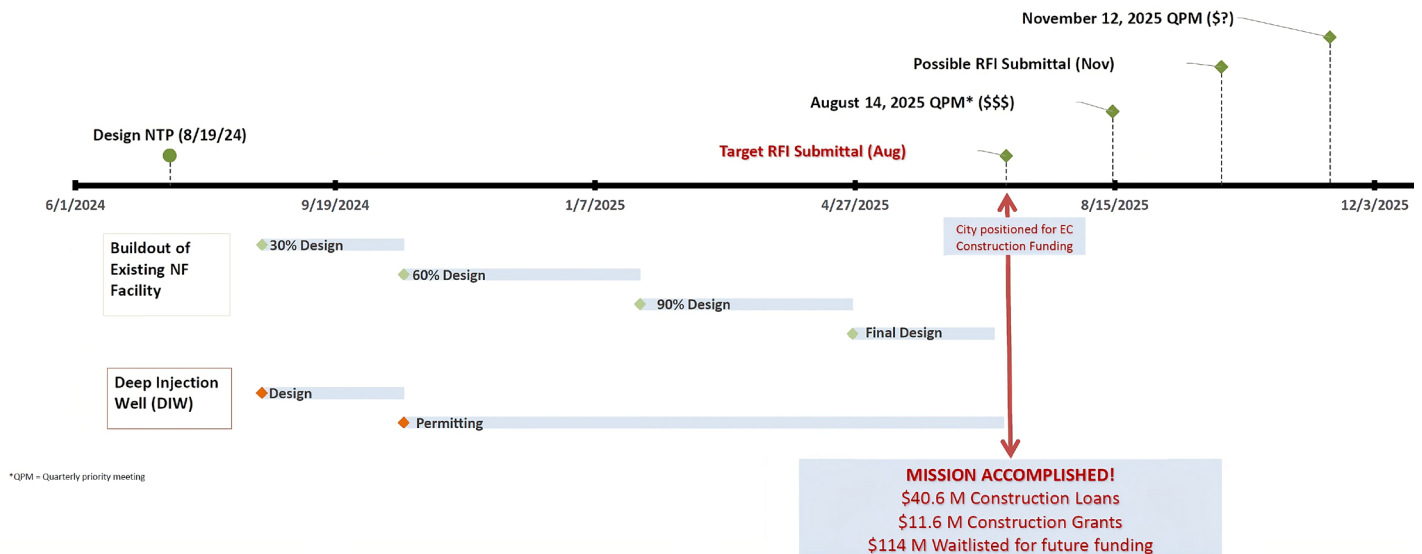

Identification, scheduling, staffing, and budgeting for all major tasks is necessary, as well as for all “incidental” project requirements (e.g., permitting, design support disciplines such as geotechnical engineering, limited excavations, “soft” digs, and surveying, any required environmental studies, planning and zoning requirements), since costs for these components tend to be magnified if they are not recognized early and planned for.

During execution of a project, there are several influences on cost that must be recognized and controlled. These include the efficiency of communications between the project team members, including communications between the Engineer, Owner, and the Contractor if it is a construction project. It is critical that a good working relationship and clear lines of communication be developed early in the project, and maintained throughout the project. Another major influence on cost is decision-making. Indecisiveness costs money. A clear chain of command and efficient decision-making process is necessary to avoid costly delays.



The project manager must continually track progress of the project against the project plan, budget, and schedule, and make adjustments during the course of the project to control costs. Finally, follow-through in certification, commissioning, and close-out of a project must be completed to avoid residual, ongoing costs from loose ends.

MBC has a strong, demonstrated record in cost control in large, complex projects. This record is evidenced in the extremely low percentage of change orders presented in MBC’s project descriptions in Section 6.4.

### 2.3.3 Quality Control

MBC takes great pride in the quality of the services and work product that we deliver to our clients. We employ a structured quality control program where deliverables (engineering documents or design documents) are reviewed at strategic stages of development (e.g., 30%, 60%, 90% completion) prior to delivery to our client. In some cases, we retain independent experts to peer review documents as part of our internal quality control program. Our record of completing projects with an extremely low level of change orders (as evidenced in our project profiles in Section 6.4) is an indication of the success of our quality control program. MBC also believes that it is critical that plant operating staff be given the opportunity to provide input on the design from the earliest stages. These personnel have first-hand, hands-on knowledge of the existing facilities, and will be operating the new systems following completion of construction.

### 2.3.4 Communications and Project Web Requirements

During execution of a project, there are several influences on cost that must be recognized and controlled. These include the efficiency of communications between the project team members, including communications between the Engineer, Owner, and the Contractor if it is a construction project. It is critical that a good working relationship and clear lines of communication be developed early in the project and maintained throughout the project.

MBC has experience with the City’s *Trimble Unity Construct e-Builder, Inc.* and *LCPtracker, Inc.* program and project management software packages. MBC staff performs regular review of available information provided on these software packages to be fully apprised of project developments and required action items. If the City elects to implement any additional software packages under this contract, relevant MBC and subconsultant staff will be trained and utilize the software, as required.

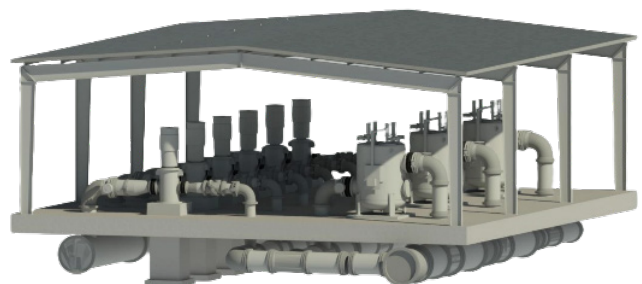

### 3. References

MBC's team has a long, proven track record of working together to complete numerous projects in South Florida. The Qualification of Bidder form provided in the RLI, has been completed and uploaded via Ionwave. Additional references were selected to best represent projects similar to the City's upcoming CIP projects and are listed below for

each team member. References are also indicated on each of the following project profiles sheet that demonstrate our team's experience and expertise in Section 6.4. We strongly encourage the City to contact these references.

<b>Firm</b>	<b>Public Entity</b>	<b>Project</b>	<b>Contact</b>
MBC	City of Boca Raton	Membrane Element Replacements (2015, upcoming 2025)	Justin Barrington, P.E. 561.338.7382 jbarrington@bocaraton-fl.gov
MBC	Seminole Tribe of Florida	WTP and Transmission Systems Redundancy/ Reliability Evaluations	Ranthus Fouch, P.E. 954.894.1060 ranthusfouch@semtribe.com
MBC	Broward County Water and Wastewater Services	PFAS Water Treatment Impact Assessment	Mark Darmanin 954.831.0960 mdarmanin@broward.org
H2M	City of Fort Lauderdale	Design Criteria Packages for Fire Stations 13 and 88	Wilfredo Negron, P.E. 954.828.3454 wnegron@fortlauderdale.gov
H2M	Town of Davie	Police Department New Emergency Generator	Keith Pursell 954.797.1191 keith_pursell@davie-fl.gov
HEE	City of Pompano Beach	Rehabilitation of the Membrane Pretreatment Pressure Filters	Phil Hyer 954.545.7030 Phil.Hyer@copbfl.com
HEE	City of Boca Raton	WTP Rehabilitation of the Membrane Pretreatment Pressure Filters	Brandon Tufts 561.338.7374 btufts@bocaraton-fl.gov
Keith	City of Pompano Beach	Parking Garage Master Water & Sewer	Fernand Thony 954.786.7923 fernand.thony@copbfl.com
Keith	Broward County Water and Wastewater Services	Engineering Services Water Wastewater Projects	George Serbanescu 954.831.0891 gserbanescu@broward.org
QuEST	Broward County Construction Management	Planned 25-30 Story Government Center	Micheal Ritus 954.357.7221 Mritus@broward.org

# 4. Project Team Form

(Submitted Electronically via Ionwave: <https://pompanobeachfl.ionwave.net>)

**COMPLETE THE PROJECT TEAM FORM ON THE ATTACHMENTS TAB IN THE EBID SYSTEM. PROPOSERS ARE TO COMPLETE FORM IN ITS ENTIRETY AND INCLUDE THE FORM IN YOUR PROPOSAL THAT MUST BE UPLOADED TO THE RESPONSE ATTACHMENTS TAB FOR THE RLI IN THE EBID SYSTEM.**

## PROJECT TEAM

RLI NUMBER 25-072

Federal I.D.# 20-4382371

### PRIME

Role	Name of Individual Assigned to Project	Number of Years Experience	Education, Degrees
Principal-In-Charge	Frank A. Brinson, P.E.	34	B.S., Env. Eng.
Project Manager	Andrew Barba, P.E.	10	B.S., Env. Eng.
Asst. Project Manager	Audra McCafferty, P.E.	34	B.S., Env. Eng.
Other Key Member	Mathew Marsh, C.G.C.	28	B.S., Surv. Mgmt.
Other Key Member	Mariell Soto, P.E.	6	B.S., Env. Eng.

### SUB-CONSULTANT

Role	Company Name and Address of Office Handling This Project	Name of Individual Assigned to the Project
Surveying	Keith and Associates, Inc. 301 E. Atlantic Blvd., Pompano Beach, FL 33060	Chuck Schramm, PSM
Landscaping	Keith and Associates, Inc. 301 E. Atlantic Blvd., Pompano Beach, FL 33060	Kelli Schueler, PLA Mark Mitchell (SUE)
Engineering	H2M Architects & Engineers, Inc. 951 Yamato Road, Suite 202, Boca Raton, FL 33431	James Roberts, P.E. (Civil) Daniel Aiello, P.E. (Structural)
Other Key Member		Kenneth Gehring, A.I.A.
Other Key Member	Hillers Electrical Engineering, Inc. 23257 State Road 7 Ste 100, Boca Raton, FL 33428	Thein Win, P.E. (Electrical) Thein Naing (Inspections)
Other Key Member	QuEST Engineering Services & Testing, Inc. 2737 NW 19th Street, Pompano Beach, FL 33069	R. N. Sailappan, P.E. (Geotechnical) Reza Javidan, P.E. (Specialty Eng.)
Other Key Member		

(use attachments if necessary)

# 5. Organizational Chart



**Prime Consultant**







**McCafferty Brinson Consulting, LLC**

Frank A. Brinson, P.E., CDT, Principal-in-Charge  
 Andrew Barba, P.E., CDT, Project Manager  
 Audra McCafferty, P.E., ENV SP, Funding Lead  
 Mathew Marsh, CGC, Construction Manager



**Project Team**

<p><b>H2M Architects &amp; Engineers, Inc.</b></p>  <p>Architectural, Structural &amp; Civil Engineering</p> <p>James J. Roberts, P.E.              Tzufit Boyle, P.E.              Patrick K. Cole, P.E.              Daniel J. Aiello, P.E.              Gregory Cellamare, P.E.              Kenneth R. Gehringer, AIA</p>	<p><b>Keith and Associates, Inc.</b></p>  <p>Surveying, Landscape Architecture &amp; Subsurface Utility Locations</p> <p>Paul Weinberg, PLA, ASLA              Michael Mossey, PSM              Mark Mitchell</p>	<p><b>Hillers Electrical Engineering, Inc.</b></p>  <p>Electrical, Instrumentation &amp; Controls Engineering</p> <p>Thein Win, P.E.              Thein Naing</p>	<p><b>QuEST Engineering Services and Testing, Inc.</b></p>  <p>Geotechnical &amp; Specialty Engineering</p> <p>R. N. Sailappan, P.E.              Reza Javidan, P.E.</p>
--	--	---	---

## 6. Statement of Skills and Experience of Project Team

To demonstrate our team's long-standing working relationship, the project listing below highlights our teams recent project experience directly related to the water and reuse treatment plant projects proposed in the City's CIP. MBC works with highly qualified consultants that complement MBC's talents and provides a full suite of services on a project by project basis. Two members of the project team, Hillers Electrical Engineering, Inc and KEITH, have been on the MBC team for this continuing consulting contract since 2016. H2M Architects and Engineers, has been added to the team for their structural and architectural experience. Quest was added to the team to provide geotechnical support, which is often required in construction bid documents.

### 6.1 Team Project Table

Project	MBC	HEE	KEITH	H2M
Pompano Beach Task 3 NF Plant Buildout Design Phase	✓	✓	✓	✓
Boca Raton Transfer Pumping System Upgrades	✓	✓		
Seminole Tribe of Florida Hollywood Water Distribution Evaluation	✓		✓	
Boca Raton Membrane Softening Process Renovation	✓	✓		
Pompano Beach WTP EC Upgrades Planning Document	✓	✓		✓
Boca Raton NF Unit and Degasifier Upgrades SDC	✓	✓		
Boca Raton Four-Log Treatment Upgrades SDCs	✓	✓		
Pompano Beach Nanofiltration Process Expansion Study	✓	✓		
Boca Raton Washwater Recovery Upgrades SDCs	✓	✓		
Pompano Beach Water System Interconnect Upgrades	✓		✓	
Boca Raton Lime Softening Backwash and Disinfection Upgrades	✓	✓	✓	
Pompano Beach Reclaimed Water Piping Mods Bidding and SDCs	✓	✓		
Pompano Beach Reuse Water Production Improvements	✓	✓		
Pompano Beach Reclaimed Water Piping Mods Bidding and SDCs	✓	✓		
Seminole Tribe of Florida Hollywood Raw Water Supply Improvements	✓	✓	✓	
Boca Raton Rehabilitation of the Membrane Pretreatment Pressure Filters	✓	✓		
Pompano Beach Reuse Water Treatment Plant Modifications	✓	✓		

## 6.2 MBC's Qualifications and Experience

MBC was incorporated as a Limited Liability Company (LLC) in Broward County on February 24, 2006. The founders and principals of MBC are Ms. Audra McCafferty, P.E., and Mr. Frank A. Brinson, P.E.

Our primary focus is on the municipal potable water, wastewater, and reclaimed water market sectors, with a specialty in membrane treatment applications. MBC also offers a range of environmental consulting, engineering design, and construction administration services, as well as permitting and regulatory compliance consulting.

Professional engineering services offered by MBC include:

- Water and wastewater treatment facilities design and consulting
- Utility regulatory compliance consulting
- Water transmission/distribution systems design
- Wastewater collection and transmission systems design
- Utility master planning
- Design-Build
- Construction management
- Treatability studies
- Hydraulic modeling
- Permitting and compliance
- Stormwater permitting and compliance

Being a small business, we rely heavily on repeat business and “word-of-mouth” advertising between our current and potential clients. We believe that our greatest marketing asset is our reputation, and we strive to build and maintain that reputation with every project. We are proud of our record, and we strongly encourage the City to contact any and all of our references.



MBC's experience with the City's facilities and our knowledge of your regulatory position, coupled with fact that we are a small local firm, makes our team uniquely qualified to meet the City's needs very cost-effectively under this contract. It is important to note that a large portion of the individual projects that the City has scheduled over the next five years have a total value of \$3 million or less. While MBC's principals have abundant experience in managing large, complex projects, our firm targets small to mid-size projects that require a high level of technical expertise, but are under the threshold that most large firms would consider dedicating their top talent to.

The configuration of the Pompano Beach Water Treatment Plant is somewhat unusual in that it utilizes a combination of conventional lime softening and membrane softening (nanofiltration or NF) to treat the relatively highly colored Biscayne Aquifer raw water supply, which contains elevated levels of dissolved organics and disinfection by-product precursors. The product streams from these two processes are blended to produce the finished water supply, which meets all regulatory standards. Although this “combination” treatment strategy is not uncommon in South Florida, it is not common outside of South Florida, and presents a unique set of treatability, process optimization, and regulatory compliance-related challenges. It is critical that the City's consultant have the experience and expertise to meet these challenges.

MBC has a wealth of experience in working on South Florida water treatment facilities that use a similar treatment strategy, combining membrane treatment with conventional lime softening to meet their treatment objectives. Utilities that we have worked with or are working with that either currently



have a similar combined process, or are considering implementing membrane treatment to complement their existing lime treatment process, include the Cities of Boca Raton, Lake Worth, Dania Beach, and the Town of Davie, as well as Broward County Water and Wastewater Services, and Seacoast Utility Authority.

A significant portion of the potable water treatment budget in the City's CIP is for maintenance and rehabilitation of the existing lime softening process equipment. Some of the major components of the lime softening process equipment are approaching their useful service lives. MBC assisted the City in replacing the drive unit on one of the plant's solids-contact lime softening units (Infilco-Degremont Accellator). One of the primary challenges of treating the South Florida Biscayne Aquifer raw water supply, which is high in dissolved organics, color, and disinfection by-product precursors, is to cost-effectively produce a finished water supply that is aesthetically pleasing (e.g., free of color) and disinfected to regulatory standards (four-log virus treatment) without producing undesirable disinfection byproducts in the water supply. Historically, the City has successfully employed a strategy of combining conventional lime softening and NF to achieve these goals, and continues to strive to optimize the approach to improve finished water quality and the level of service to its customers. As discussed below, MBC has been a long-term partner to the City in these efforts.

Starting in 2018, the City and MBC undertook a project aimed at substantially improving the NF process by optimizing finished water quality, reducing power consumption (and associated costs), and optimizing chemical usage as part of the City's routine periodic NF membrane element replacement. MBC assisted the City in designing, permitting,

and constructing a new NF membrane pilot unit that provides a near perfect pilot-scale representation of the City's full-scale NF process. The pilot unit was designed and permitted to be operated in parallel with the full-scale plant using the same raw water supply, but with the ability to adjust critical operating parameters such as chemical treatment regimens, membrane flux rates, and process recovery rates without affecting operation of the full-scale plant. Furthermore, the treated water from the pilot unit is recovered as treated potable water, and concentrate is disposed of in the City's existing injection well system, enabling the City to operate the pilot unit indefinitely without wasting water or creating a new by-product stream. This has given the City the unique ability to test any potential adjustment or improvement to the plant operating protocols without risk to the full-scale plant systems.

As part of the NF membrane replacement effort, MBC assisted the City in developing and conducting a pilot testing program to not only prequalify manufacturers and select new membrane elements for the scheduled element replacement, but to also develop a new treatment protocol that enables the complete elimination of chemical pretreatment (sulfuric acid and antiscalant) of the raw water supply. The pilot testing program was conducted from April 2018 through January 2019. Through this testing, the City not only identified a membrane element selection that meets all of the City's treated water quality and performance goals, but demonstrated long-term, stable membrane operation with no chemical pretreatment of the raw water supply.

With MBC's assistance, the City completed the membrane element replacement in the full-scale plant in April 2020, and the plant has operating successfully since that date with



no chemical pretreatment. The new membrane element selection, and the elimination of sulfuric acid and antiscalant from the process, have resulted in actual power and chemical cost savings of approximately \$245,000 annually. Furthermore, this has eliminated the labor and expenses associated with maintaining these large chemical storage and feed systems at the plant. The annual cost savings resulting from this effort are expected to be well over \$2 million over the life of the membranes. Perhaps most importantly, this project has eliminated the need for the plant operators to handle large quantities of potentially dangerous chemicals (i.e., 93% sulfuric acid) on a daily basis, resulting in safer working conditions for plant operating staff and reducing liability to the City. The Pompano Beach plant is one of only two large NF drinking water facilities in Florida (and likely the country) that operate with no chemical pretreatment of the feedwater supply.

In 2019-2020, MBC prepared the *Gravity Filter Refurbishment and Alternative Treatment Technology Study* for the City's water treatment plant. This study identified the rehabilitation needs of the existing multimedia gravity filters and compared a conceptual rehabilitation project to other treatment technology alternatives (e.g., retrofitting the existing filter structures with ultrafiltration (UF) membrane systems based on several different UF system manufacturers.

These alternatives were evaluated on a capital, operating, and total project cost basis, as well as considering potential finish water quality improvements. These two scenarios were also evaluated relative to the alternative of expanding the City's existing NF process. This document provides a sound basis for long-term, strategic planning and decision-making for future renewal and replacement and upgrade projects at the water treatment plant.

In 2013, MBC assisted the City in developing an integrated Unidirectional Flushing and Valve Exercising Program. This is an ongoing program, currently being executed by the City's water distribution system operating staff, which enables the City to maintain excellent drinking water quality in all areas of the distribution system as well as maintain the mechanical integrity and functionality of the distribution infrastructure. This is yet another example of MBC and the City's collaboration to continuously improve the already high level of service that the City provides to its customers.

In addition to engineering planning, the City will have a need for regulatory compliance consulting to maintain continued compliance with changing water quality and operations-related regulations. As noted in our letter of transmittal, in 2014 MBC assisted the City in obtaining certification by the Broward County Health Department of the City's water treatment plant as a four-log virus treatment facility. This certification documents that the water treatment plant

provides an upgraded level of disinfection of the City's drinking water supply, providing a safer source of drinking water for the City's customers and substantially reducing the City's exposure to the risk of non-compliance actions under the Federal Ground Water Rule (e.g., public notifications and/or boil water orders). Pompano Beach was one of the first utilities in Broward County to achieve this certification. Continued compliance with these requirements will likely require additional consulting services as the City continues to optimize and improve the water treatment process and related facilities.

In addition to the above-described disinfection-related regulatory compliance efforts, the City must continue compliance with the Disinfectant/Disinfection By-Product Rule (D/DBPR). The City has been very proactive and diligent in developing and implementing sound strategies to comply with these regulatory requirements. These efforts have included not only the recent treatment process improvement studies and process modifications, but the City's decision to leverage nanofiltration membrane technology to improve the finished water quality, aimed in part at ensuring compliance with the D/DBPR. As a result, the City of Pompano Beach is one of South Florida's leading utilities in compliance efforts with these recent regulations.

Because of the manner in which these sets of regulations are written, the City's plant operating staff (as with most utilities in South Florida) must maintain a delicate balance between maintaining sufficient free chlorine residual disinfectant contact time to provide 4-log disinfection, without "over disinfecting" and exceeding the DBP (i.e., trihalomethanes and haloacetic acids) maximum contaminant levels. The City's consultant must be familiar with the City's specific situation, and the specific characteristics of the City's treatment processes, with respect to these regulations. There is no other consulting engineering firm that has as much experience and background knowledge in this area, specifically with the Pompano Beach system, as MBC. Furthermore, MBC has demonstrated a willingness and ability to quickly and cost-effectively respond to the City's needs in this area.

Another regulatory initiative that likely will affect the City over the next five years is the South Florida Water Management District's (SFWMD) continued emphasis on the use of Alternative Water Supplies (AWS). The City of Pompano Beach is in a relatively good position with respect to this effort, having one of the few well-developed reclaimed water reuse programs in South Florida. Again, Pompano Beach was proactive in the implantation of reclaimed water reuse technology, and is leading South Florida utilities. Expansion of the City's reclaimed water system will assist the City in staying at the cutting edge of reclaimed water usage in South Florida.

## 6.3 Qualifications and Experience of MBC Team

MBC has selected our team not only for their experience and expertise to support MBC on this contract, but for their familiarity with the City of Pompano Beach and your facilities. In addition, we have selected our team to maximize participation under the City's Local Business Program. The following summarizes the skills and experience of each firm supporting MBC on this contract.



### 6.3.1 H2M Architects + Engineers

H2M is a multi-disciplined professional consulting and design firm, proud of our long history of client service and consistent ability to meet tough architectural, engineering, and environmental challenges head-on. In business for 90+ years, H2M expanded to Florida in 2020. The foundation of our success, since inception, lies in the strong relationships we have cultivated with our clients. Our unwavering commitment to our mission and values has been the driving force behind our business practices, evident in the enduring partnerships we have maintained with clients who have trusted us with their facilities for decades. It is the expertise we've developed through these valuable client relationships that allows us to grow in new regions. H2M offers comprehensive services to meet the needs of the Florida region across various market sectors, including government, education, water and wastewater, public safety, and real estate. We are currently serving clients throughout South Florida and on the Gulf Coast. H2M is proud of its track record of on-time project completion, within our clients' budgetary requirements.

H2M holds several on-call contracts with municipalities and public agencies and have established standards and approaches for work of this nature. We understand that sometimes work under these contracts are emergencies that require a swift response. With more than 580 technical and support personnel in-house, H2M has the staff available to serve our clients when they need us the most. As a full-service, multi-discipline firm, H2M offers the benefit of staffing nearly any project with in-house staff. The firm comprises architects; engineers; interior designers; GIS specialists; scientists; and more.

#### *Structural Engineering*

H2M has completed thousands of structural assessments, forensic investigations, structural analyses, and designs for our public clients. In addition, we have completed projects

for lending institutions, attorneys, national clients, private developers, property owners, insurance companies, and contractors. The firm's structural experience includes existing condition structural surveys, cause and origin investigations, mechanical equipment dunnage, deep foundation designs, foundation designs, stability analysis, structural concrete analysis and repair, field engineering and site representation, structural steel connection design, seismic retrofits, façade engineering, structural design of new buildings and special structures, structural design of building expansions, bulkhead design, retaining structures design, and alteration and renovation design. H2M also supports our clients with permitting and public bidding. Engineering services during construction include shop drawing review, contract administration, construction inspection, punchlist preparation, and closeout services.

#### *Architecture/Building Design*

H2M is fully qualified to assist with the preparation of construction plans, work orders, and general architectural work as required to demolish, construct new, and/or maintain facilities within the City's jurisdiction, as well as determine the structural integrity of facilities within the City. H2M's staff also has extensive experience in the management of multi-discipline architectural and engineering projects. Our experience includes conceptual plans for new facilities; capital improvement projects; design of roof systems, window replacements, door replacements, as well as all other envelope components; repairs and additions; structural modifications to existing facilities; upgrading existing facilities to meet ADA requirements; interior design; and historic renovations. H2M also supports our clients with permitting and public bidding. Services during construction include shop drawing review, contract administration, construction inspection, punchlist preparation, and closeout services.

#### *Water Resources & Wastewater Engineering*

H2M began as a water resources engineering firm 90+ years ago. Our water resource engineers provide personal service and focused, cost-effective solutions to meet the demands of any planning, design, and construction project for any one of our municipal, governmental, industrial, or private client base. With multi-discipline and fully functional in-house professional staff, H2M strives to meet and exceed client goals and expectations to successfully complete projects, with the knowledge of and sensitivity to community and environmental concerns. The areas of our expertise in the field of public water supply include:

- Emerging contaminant water treatment evaluation and optimization
- Regulatory compliance assistance
- Grant writing and project funding support

- Water resource development, design, and management
- Water system master, long range, and capital improvement planning
- PFAS and VOC removal treatment systems
- Supply well construction and rehabilitation
- Water treatment systems
- Pump station/electrical system rehabilitation
- Water storage tanks new, rehabilitation, and inspection
- Distribution system/backflow prevention design and analysis
- Instrumentation, control, and SCADA systems
- Groundwater modeling
- System/hydraulic modeling
- Chemical treatment/chemical compliance systems
- Construction administration and inspection

H2M also offers wastewater engineering services to municipal, private, and industrial clients, including advanced treatment systems for water reuse. Our services begin with a thorough characterization and quantification of the client's wastewater, and are continued through regulatory appraisals, planning, design, construction services, and start-up. Preparation of operation and maintenance manuals and operator training following construction services to monitor plant performance for compliance with discharge permit requirements, and, in some cases, operation and maintenance of facilities can also be provided. Our wastewater treatment design experience includes facilities with flows less than 30,000 gallons per day to over 10 million gallons per day. We have design experience in upgrading existing sewage treatment facilities from secondary to advanced treatment for nutrient removal.

### *Environmental Engineering*

When it comes to environmental services, H2M is accustomed to tackling tough problems. At H2M, we are in the business of meeting challenges, preserving the environment, and protecting communities. We turn brownfields into playing fields, improve indoor air quality, and monitor the safety of groundwater. Whether we are conducting monthly sampling, completing a due diligence evaluation, or designing a chemical storage tank, our responsive and dedicated team will make any environment work. H2M's environmental services include environmental engineering; environmental health and safety; site investigation and remediation; property transaction support; soil vapor intrusion investigation and mitigation; geology/hydrogeology; soil and groundwater characterization; groundwater modeling/fate and transport modeling; toxic and hazardous material/waste management; Chemical Bulk Storage/Petroleum Bulk Storage (CBS/PBS) design, management, inspection, and permitting; air emission permitting, pollution control, reporting and monitoring; facility closures/liability limitation; environmental permitting; industrial hygiene; hazmat surveys; mold, asbestos, and lead services; and forensics engineering.



### **6.3.2 Hillers Electrical Engineering, Inc.**

Hillers Electrical Engineering, Inc., located in Boca Raton, Florida, has been in business since 1994. Our staff offers unsurpassed experience, expertise, and personalized service in electrical engineering design, control application programming, and construction management. Our electrical design services include power, control, instrumentation, telemetry, start up assistance, construction management services and PLC/computer programming for County and State municipal agencies as well as private industry.

Our office is fully equipped with state-of-the-art computer systems and engineering software to help ensure a quality and cost-effective product. Software programs include AutoCAD SKM fault current/coordination/arc flash program, generator sizing programs, and 3- dimensional lighting calculations program.

HEE design staff brings vast electrical, instrumentation and telemetry design and project management experience in major expressway, DOT roadway systems, toll plaza and parking lot lighting systems; supervisory control and data acquisition (SCADA) systems; water/waste treatment plants, storm water pumping stations, lift stations, state-of-the-art distributed control systems, variable frequency speed drive analysis for facility efficiency improvements, ASR wells; implementation of commercial industrial load control program systems for large industrial power users, value engineering, energy audits, cost estimates, testing, start-ups, all types of security systems, fire alarm; low, medium and high voltage distribution systems, normal and stand by generation, short circuit calculations, fault current calculations, protective device coordination; professional and amateur sports complex lighting systems; power, control, instrumentation for major fuel storage and refining facilities in the U.S. and internationally.

HEE provides a variety of electrical, instrumentation and telemetry design and construction management tasks including:

- Low, Medium, and High Voltage Power Distribution Systems
- Motor Control Centers (MCCs)
- Distribution Panels
- Voltage Drop Calculations
- Variable Frequency Drive (VFD) Application
- Luminaire Calculations
- Short-Circuit Calculations, Protective Device Coordination & Arc Flash
- Standby Generator Systems
- Fire Alarm and Security Systems

- Instrumentation & Control Systems
- Telemetry Systems
- Supervisory Control and Data Acquisition (SCADA) Systems
- Shop Drawing Review
- Energy Audits
- Cost Estimates, Testing, and Start-Up

HEE has provided electrical engineering services for multiple projects for the City of Pompano Beach. A few of these projects include the City of Pompano Beach WTP Flowmeter Replacement, Reclaimed WTP Piping Modification Improvements, Reclaimed WTP Motorized Valve, Filter Feed Pumps and Low-Pressure Distribution Pumps Improvements, and the Nanofiltration Process Expansion Study and Design. The nature of Consulting is such that responsiveness is the key to maintaining a long-term relationship. HEE takes great pride in ensuring that we are immediately accessible and responsive to our client's needs. This is demonstrated in the excellent relationship we have established over the last 31 years with many municipalities and environmental consulting firms.



### 6.3.3 Keith & Associates

KEITH is a 60 + year old, majority woman owned, transdisciplinary firm, based in Florida delivering a broad range of projects internationally. Based in Florida, KEITH has office locations in Broward, Miami-Dade, Palm Beach, St. Lucie, and Orange Counties. Our team of over 200 professionals is working every day to deliver on our mission to create, expand upon, preserve, and enhance our communities. The KEITH Team has maintained multiple contracts directly with the City of Pompano Beach, serving both as a prime consultant and subconsultant for many years. These projects include the existing contracts for Pompano Beach Water and Re-Use Treatment Projects, Professional Engineering Services, Professional Survey Services, Professional Landscape Architecture Services, and Pompano Beach Sustainability Projects. This extensive experience has enabled KEITH to develop a deep understanding of the City's unique needs and establish enduring, strong relationships with City Staff. The professionals of KEITH continue to take great pride in the success of their undertakings. We look forward to the opportunity to provide you professional services.

#### *Surveying and Mapping*

The expertise of our Land Surveying staff combined with our South Florida surveying experience of over 100 years has resulted in a tremendous database of knowledge and information. The ability to offer in-house surveying and mapping capabilities provides for a more comprehensive

unified team. Services include boundary, topographic, control, wetland, mitigation, route, aviation, bathymetric, Mobile LiDAR, GIS, GPS, as-built, American Land Title and coastal surveys, legal descriptions, right-of-way mapping, design base sheets, title review, DTMs, differential leveling, construction stakeout, platting, expert witness surveying, and mapping services.

The firm maintains eight full-time field crews to provide for our clients on an as-needed basis. Our entire field staff has received Maintenance of Traffic (M.O.T.) Safety Training currently required by the Florida Department of Transportation for work within public roadways. We understand the importance of these security requirements and are in 100% compliance for the safety of our staff and the public. KEITH has placed a strong emphasis on quality surveying and mapping practices and procedures. This focus ensures that our surveying personnel are committed to exceeding your expectations.

#### *Landscape Architecture*

Our Landscape Architecture Department specializes in the creative fusion of architecture, landscape architecture, and the environment. The ability to offer in-house landscape architecture design capabilities, ISA certified arborist and certified landscape inspector, provides for a more comprehensive unified team.

Our team has provided innovative designs for institutional and commercial projects, residential and mixed-use developments, streetscape and roadway beautification, active and passive parks, plazas and various urban redevelopments. Whether it is in meeting the code of landscape ordinances with creativity or in creating spectacular lush destinations, we bring experience, knowledge, fresh energy and innovation to each project. Our approach is one of an extension of our clients' staff, offering guidance and assistance to make smart, long-term decisions that result in greater value for them, their projects, their stakeholders, and our community as a whole. Regardless of the scope of the project, we pay special attention to architectural and landscape detail and welcome every opportunity to improve our environment.

#### *Subsurface Utility Engineering (SUE)*

Subsurface Utility Engineering (SUE) provides accurate mapping of existing underground utilities, eliminating the need to "find out the hard way" that plotted utility information was inaccurate. Performed during the project design process, Subsurface Utility Engineering can help utility owners, designers, engineers, and contractors avoid conflicts or project delays. To avoid these issues, many clients turn to KEITH, a recognized leader in Subsurface Utility Engineering.

KEITH's staff has the expertise required to deliver accurate utility information needed by clients, engineers, contractors, and designers to make informed decisions. Using KEITH's SUE services will result in enhanced accuracy of project designs and cost estimates by collecting and mapping underground utility data that was primarily unknown.

Our team of experts also includes utility coordination managers with extensive experience in working with facility owners, design teams, and agencies to mitigate conflicts between existing facilities and proposed designs. Our relationships with area utility agencies serve to facilitate negotiations, expedite requests for available records, and ultimately achieve the successful certification of each project.



### 6.3.4 QuEST Engineering Services & Testing

Quest Engineering Services & Testing, Inc. (QuEST) is a Florida-based engineering firm established with the vision of delivering the technical capabilities of a large company while maintaining the personalized service of a small firm. QuEST has built a reputation for technical excellence, responsiveness, and innovative problem-solving. The firm has successfully completed a wide variety of projects throughout Florida, as well as in Texas, the Bahamas, and the Turks & Caicos Islands. QuEST is committed to delivering smart, efficient, and cost-effective engineering solutions tailored to each client's goals.

#### *Geotechnical Engineering*

QuEST offers a comprehensive range of geotechnical engineering services delivered by a highly professional and experienced team. Our geotechnical expertise spans across numerous large-scale commercial, educational, residential, and municipal projects throughout South Florida. Our team is well-versed in the investigation of subsurface conditions and materials, evaluation of site-related risks, foundation and earthwork design, and construction monitoring. We provide detailed, performance-based foundation design recommendations that are tailored to the specific conditions of each site. This approach allows our clients to proceed with development using the most cost-effective foundation alternatives, informed by reliable data and engineering judgment.

Geotechnical services include:

- Soil Borings
- Percolation Tests
- Shallow Foundation Design
- Deep Foundation Design
- Earthwork Monitoring

- Pile Installation Monitoring
- Pile Load Tests (Compression, Tension & Lateral)
- Vibro-flotation Design & Monitoring

#### *Specialty Testing*

QuEST delivers a wide array of specialty testing services, supporting industries such as construction, automotive, and aviation. With certified inspectors who are also licensed Professional Engineers, we provide not only accurate data but also on-site expertise to address unexpected conditions in real time. Our commitment to quality and code compliance ensures that your project meets all regulatory standards and performs as intended. Our team includes certified special and threshold inspectors recognized across Dade, Broward, and Palm Beach counties. All inspections and tests are conducted in accordance with the Florida Building Code, and often enhance both project safety and efficiency.

Specialty testing services include:

- Ground Vibration (Seismograph) Monitoring
- Light Level Survey
- Sound Level Surveys
- Balcony Rail Load Tests
- Slab Moisture Intrusion/Transmissivity Tests
- Relative Humidity/Temperature Monitoring
- Paint Thickness Tests
- Coefficient of Friction Tests
- SEM/EDX Analysis of Stains, Pipe Build-up, etc.
- Petrographic Analysis

### 6.4 Project Profiles

The MBC team has selected project profiles to demonstrate the team's technical expertise, knowledge of City operations, and depth of experience related to the City's scope of service for these water and reuse treatment plant facilities.





#### Client

City of Pompano Beach

#### Scope of Services

Evaluation and development of conceptual designs and opinions of capital and operating costs for nanofiltration (NF), reverse osmosis (RO), granular activated carbon (GAC), and anion exchange (AIX) upgrades to the water treatment to comply with proposed PFAS regulations. On-site pilot testing of GAC and AIX alternatives.

#### Contact

Mr. Phil Hyer  
 Utilities Treatment Plants  
 Superintendent  
 City of Pompano Beach  
 1205 N.E. 5<sup>th</sup> Avenue  
 Pompano Beach, FL 33061  
 954.545.7030  
 Phil.hyer@copbfl.com

#### Start Date

September 2023

#### Completion Date

April 2024

#### Key MBC Staff

Audra McCafferty, P.E.  
 Frank A. Brinson, P.E.  
 Andrew H. Barba, P.E.

#### Key Features

- Evaluation of NF, RO, GAC, and AIX treatment technologies on performance and cost basis.
- On-site pilot testing of GAC and AIX.
- Development of preliminary opinion of probable construction costs.
- Identified NF as the most cost-effective treatment technology for Pompano Beach.

#### Benefit to the City

Enabled the City to secure \$9.6 million in grant funding for planning and design and provided a roadmap for timely compliance with PFAS regulations.

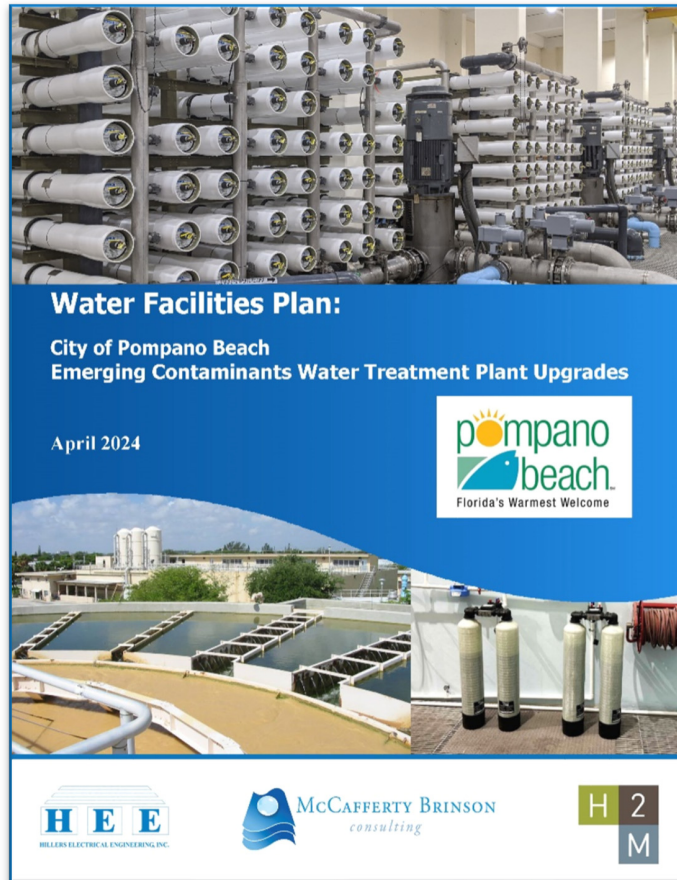

First Florida SRF approved planning document and first executed loan agreement under the Bipartisan Infrastructure Law emerging contaminant projects.

## Background

The Pompano Beach Water Treatment Plant (WTP) utilizes a combination of conventional lime softening (40 mgd) and nanofiltration (NF) membrane treatment (10 mgd) to produce the City's blended finished water supply.

In March 2023, the USEPA proposed a National Primary Drinking Water Regulation (NPDWR) for certain per- and polyfluoroalkyl substances (PFAS) with an estimated compliance date of April 2029. The 2021 Bipartisan Infrastructure Law (BIL) established an Emerging Contaminants funding source, from which Federal grant funds were made available to drinking water utilities for implementation of water treatment plant upgrades that are necessary to provide compliance with the proposed PFAS regulations. As with nearly all utilities in South Florida who utilize conventional lime softening treatment of the surficial Biscayne Aquifer raw water supply, the Pompano Beach WTP will require substantial upgrades to comply with the proposed PFAS regulations. McCafferty Brinson Consulting, LLC (MBC) assisted the City in securing a grant (loan with 100% principal forgiveness) in the amount of \$9,595,000 for PFAS-related upgrades to the City's WTP.

**The Project**

The Emerging Contaminants (EC) grant/loan program is administered by the State of Florida Drinking Water State Revolving Fund (DWSRF) program. To maximize the opportunities for project funding under this program, a sponsor (utility) must be proactive and have a structured and detailed strategic plan and schedule for completing all necessary administrative activities (such as public meetings, financial feasibility studies, commission adopting and authorizing resolutions, and loan agreement execution), as well as preparing and submitting all required documentation to the DWSRF for review and approval, in a timely manner. One of the most critical funding document submittals is the Facilities Plan and Planning Document, which provide the definition of the project (i.e., identification of the most cost-effective treatment technology to be utilized) for approval by the DWSRF prior to award of the final design funding. Therefore, the content and findings of this document are critical to a successful project, and formal approval of the Planning Document by the DWSRF is a major milestone in securing the EC funding.

In addition to the non-treatment-related activities (such as environmental assessments, assessment of socio-economic conditions, land use, etc.) required by DWSRF, the Facilities Plan included a treatment technology alternative analysis that evaluated nanofiltration (NF) and reverse osmosis (RO) membrane treatment, as well as granular activated carbon (GAC) and anion exchange (AIX) upgrades to the existing lime softening process for removal of PFAS. The analysis included the evaluation of existing treatment process performance and water quality, identification of treatment needs, and development of conceptual designs and capital and operation and maintenance (O&M) cost estimates for each technology alternative. The study also included over 5 months of on-site pilot testing of the GAC and AIX technologies. Pilot testing of membranes was not necessary because the City’s full-scale NF facility provided sufficient operating data necessary for comparison to the GAC and AIX alternatives. The Facilities Plan was completed in April 2024 and concluded that a 10 mgd expansion of the City’s existing NF facility is the most cost-effective alternative for achieving compliance with the proposed PFAS regulations in a timely manner.

**With MBC’s assistance, Pompano Beach was the first utility in South Florida to receive an executed loan agreement for funding under the DWSRF Emerging Contaminants program.**

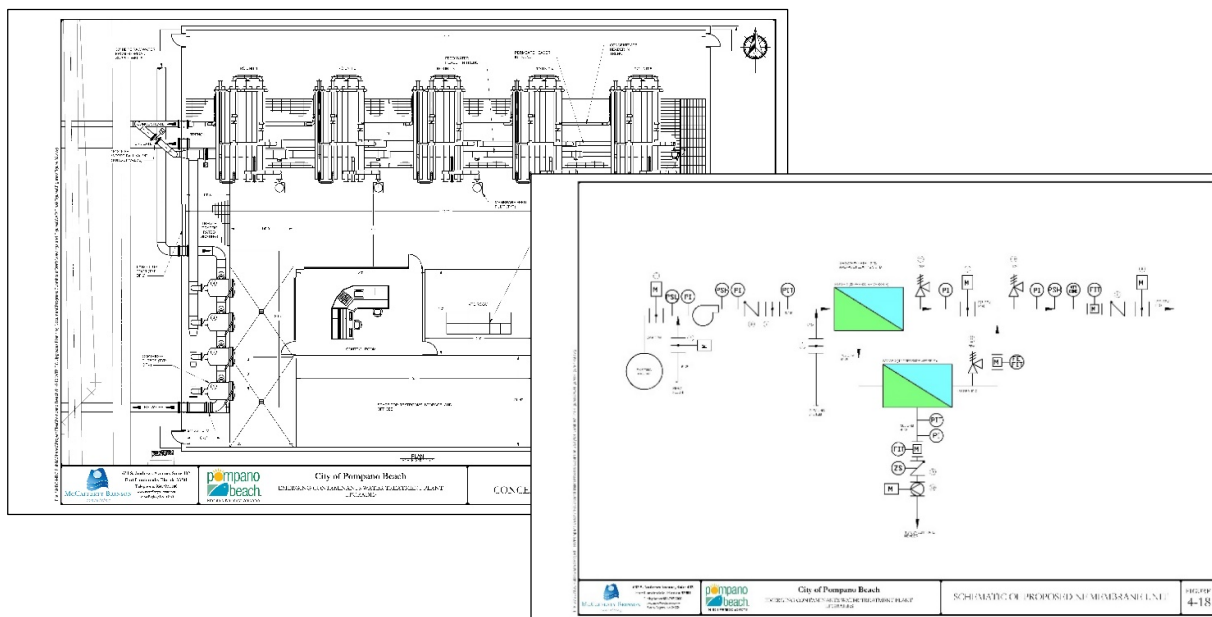



**Client**  
City of Pompano Beach

**Scope of Services**  
Prepared and submitted documentation to the SRF to procure construction loans/grants.

**Contact**  
Mr. Phil Hyer  
Utilities Treatment Plants Superintendent  
City of Pompano Beach  
1205 N.E. 5<sup>th</sup> Avenue  
Pompano Beach, FL 33061  
954.545.7030  
phil.hyer@copbfl.com

**Start Date**  
08/2017

**Completion Date**  
Ongoing

**Construction Funds Allocated**  
\$40.6 million loans  
\$11.6 million grants

**Key MBC Staff**  
Audra McCafferty, PE  
Andrew Barba, PE

**Key Features**  
Project included assistance to prepare and submit Request for Inclusion packages to meet an extremely aggressive design timeline to secure funding for

**Benefit to the City**  
SRF funding enables communities to secure financing at lower interest rates in an effort to not raise user rates and allows the City to implement much needed water infrastructure improvements.

## State Revolving Fund (SRF) Funding Assistance for PFAS Water Treatment Plant Improvements Projects - Pompano Beach, Florida

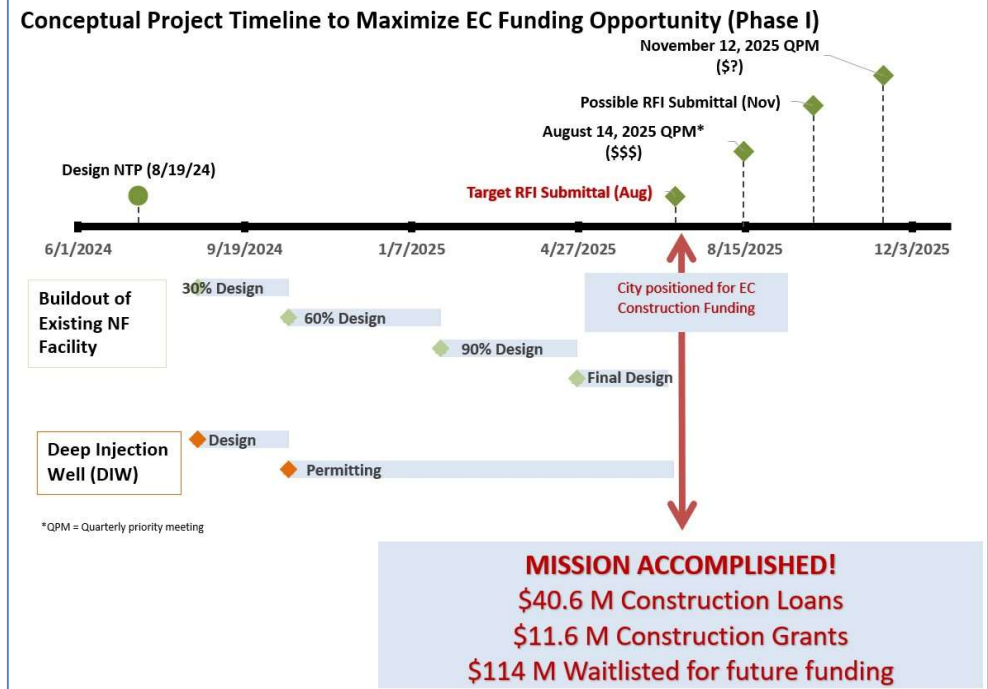

### Background

The City of Pompano Beach (City) owns and operates a 50 million gallon per day (mgd) water treatment plant that utilizes both conventional lime softening (LS) (40 mgd) and nanofiltration (NF) membrane (10 mgd) processes to treat raw water from the surficial Biscayne Aquifer. The City’s existing NF facility was originally designed to be expandable to 20 mgd within the existing building. On April 10, 2024, the United States Environmental Protection Agency (USEPA) released the National Primary Drinking Water Regulation (NPDWR) for per- and polyfluoroalkyl substances (PFAS). The City’s water sampling program has identified the presence of PFAS constituents at levels exceeding the maximum contaminant levels (MCLs) established in the PFAS NPDWR in both the raw and finished treated water. Therefore, substantial upgrades to the water treatment process are required for compliance with the PFAS NPDWR.

In 2023, the MBC assisted the City with a Request for Inclusion (RFI) submittal to secure funding for planning/design. The City secured a Planning/ Design Loan: \$9,595,000 with 100% principal forgiveness, effectively securing a grant for the planning and design of improvement to meet the PFAS compliance deadline in April 2029.

## The Project

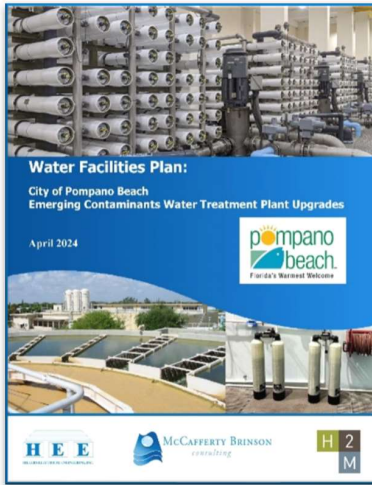

MBC prepared a *Facility Plan Emerging Contaminants Water Treatment Plant Upgrades (June 2024 and Revised July 2025)* and design plans and specifications which were approved by SRF in July 2025. The City authorized MBC to pursue additional SRF funding for construction costs of the PFAS Water Treatment Plant (WTP): Phase I Buildout of NF Facility and the Deep Injection Well (DIW) (IW2) projects. MBC has assisted the City with procuring funds in both CWSRF program and DWSRF program.

To acquire SRF funding for the City, MBC's scope of services included the following:

- Prepare and Submit Request for Inclusion Packages.
- Prepare and Submit Water Facilities Plans.
- Conduct Public Meetings to present Water Facilities Plans
- Prepare, Submit, and Coordinate Loan Application and Agreement Packages.
- Assistance with SRF-Compliance Components of Construction Contract Documents.
- Provide SRF Compliance Services during construction.

MBC prepared the design documents conforming to the selected design alternative in the planning document. The design of the improvements (WTP and DIW) and RFI submittal was prepared under an extremely aggressive timeline of nine months in order to compete for the largest pool of funding release available for the fiscal year.

## Secured Funding:

### **PFAS Water Treatment Plant: Phase I Buildout of NF Facility**

- Planning/ Design Loan: \$9,595,000 with 100% principal forgiveness
- Construction Loan: \$30,000,000 with \$6,000,000 principal forgiveness
- Construction Loan Waitlist: \$114,000,000 for future funding

### **PFAS Water Treatment Plant: Deep Injection Well (IW -2):**

- Construction Loan \$16,200,000 with \$5,595,305 principal forgiveness

**Client**

City of Pompano Beach

**Scope of Services**

Prepared and submitted documentation to the FDEP to procure numerous SRF loans.

**Contact**

Dr. Tammy Good  
Capital Plan Improvement Manager  
City of Pompano Beach  
1205 N.E. 5th Avenue  
Pompano Beach, FL 33061  
954.786.5512  
Tammy.Good@copbfl.com

**Start Date**

08/2017

**Completion Date**

Ongoing

**Funds Allocated**

\$90 million loans  
\$21 million grants

**Key MBC Staff**

Audra McCafferty, PE  
Andrew Barba, PE

**Key Features**

Project included assistance to prepare and submit Request for Inclusion packages, Water Facilities Plans, loan application and agreement packages and coordinate the SRF-Compliance components of construction contract documents and construction-phase SRF compliance administration.

**Benefit to the City**

SRF funding enables communities to secure financing at lower interest rates and allows the City to implement much needed water infrastructure improvements. Compliance with the loan agreement terms is critical to complete the projects.

## State Revolving Fund (SRF) Project Funding Procurement Assistance

Pompano Beach, Florida



### Background

The City of Pompano Beach (City) owns and operates potable water, wastewater, and stormwater utility systems to serve customers within the City's service areas. The City intended to fund several projects included in their current Capital Improvement Plan using State Revolving Fund (SRF) loan funding.

There are currently two SRF programs administered by the Florida Department of Environmental Protection (FDEP): The Clean Water State Revolving Fund (CWSRF) created under the Clean Water Act, and the Drinking Water State Revolving Fund (DWSRF) created under the Safe Drinking Water Act. Projects that involve wastewater collection, wastewater treatment or stormwater improvements may be submitted to the CWSRF program and projects that involve potable water distribution or water treatment may be submitted to the DWSRF program. MBC has assisted the City with construction and design loans funding through both programs.

### The Project

The City authorized MBC to pursue SRF funding for planning, design and construction costs for multiple projects in the City's drinking water, wastewater collection, and stormwater systems. MBC has assisted the City with procuring funds in both CWSRF program and DWSRF program.

To acquire SRF funding for the City, MBC's scope of services included the following:

- Prepare and Submit Request for Inclusion Packages.
- Prepare and Submit Water Facilities Plans.
- Conduct Public Meetings to present Water Facilities Plans
- Prepare, Submit, and Coordinate Loan Application and Agreement Packages.
- Assistance with SRF-Compliance Components of Construction Contract Documents.
- Provide SRF Compliance Services during construction.

**State Revolving Fund (SRF) Project  
Funding Assistance**  
Pompano Beach, Florida

MBC has assisted the City in obtaining \$90.4 million in conventional loans, of which \$21.3 million was in the form of grants (principal forgiveness) from the State of Florida's SRF Programs. Projects that have received planning/design and or construction Clean Water or Drinking Water SRF funds are as follow:

**Clean Water SRF Funded:**

- The following projects were under a loan totaling \$8,672,655.90:
  - 2<sup>nd</sup> Street and Gateway Drive Stormwater Improvements
  - NE 27<sup>th</sup> Avenue and NE 16<sup>th</sup> Street Stormwater Improvements
  - Kendall Lake Stormwater Improvements
- N.E. 3<sup>rd</sup> Street & N.E. 4<sup>th</sup> Street Drainage Improvements: \$1,840,250
- NW 16<sup>th</sup> Lane Drainage Improvements: \$1,832,500
- US-1 and NE 14<sup>th</sup> Street Stormwater Improvements: \$4,511,500
- NE 10<sup>th</sup> Street and Dixie Highway Stormwater Improvements: \$500,000
- NW 7<sup>th</sup> Lane and NW 7<sup>th</sup> Terrace Drainage Improvements: \$125,000
- SE 15<sup>th</sup> Ave: \$250,000
- South Riverside Stormwater Drainage Improvement Project: \$4,735,500
- City of Pompano Beach Phase 1- Deep Injection Well (IW -2):
  - \$16,200,000 with \$5,595,305 principal forgiveness
- Non-Sewer Area C Sanitary Sewer Improvements: \$2,420,091

**Drinking Water SRF Funded**

- Emerging Contaminants Water Treatment Plant Upgrades
  - Planning/ Design Loan: \$9,595,000 with 100% principal forgiveness
  - Construction Loan: \$30,000,000 with \$6,000,000 principal forgiveness
- Installation of Backflow Preventers & Meters at 4 Interconnections: \$402,790 with \$125,040.16 principal forgiveness
- C-51 Reservoir Capacity Purchase Project: \$9,200,000

**Client**

City of Pompano Beach

**Scope of Services**

SRF Compliance Services during the Construction Phase

**Contact**

Dr. Tammy Good  
Capital Improvement Plan  
Manager  
City of Pompano Beach  
1205 N.E. 5<sup>th</sup> Avenue  
Pompano Beach, FL 33061  
954.786.5512  
tammy.good@copbfl.com

**Start Date**

05/2023

**Completion Date**

2023 and ongoing

**Construction Costs**

Over \$7 million

**SRF Loan Amount:**

Over \$12 million

**Key MBC Staff**

Andrew Barba, P.E.  
Audra McCafferty, P.E.  
Mariell Soto, P.E.  
Amanada Esposito

**Key Features**

Assistance with SRF loan agreement compliance during the construction phase of a project.

**Benefit to the City**

SRF funding enables communities to secure financing at lower interest rates and allows the City to implement much needed water infrastructure improvements. Compliance with the loan agreement terms is critical to complete the projects.

## Construction Phase State Revolving Fund (SRF) Compliance Services for Several Stormwater Improvements Projects Pompano Beach, Florida



## Background

McCafferty Brinson Consulting, LLC, assisted the City of Pompano Beach with procurement of Clean Water State Revolving Fund (CWSRF) Program loans for the construction cost of several stormwater drainage improvement projects. This scope of services provided SRF Compliance Services during the Construction Phase of the several stormwater capital improvement projects:

- N.E. 3rd Street & N.E. 4th Street Drainage Improvements
- NW 16th Lane Drainage Improvements
- NE 27th Avenue and NE 16th Street Stormwater Improvements

## The Project

The scope of services includes:

- CWSRF Compliance Monitoring
- SRF Bid Document Submittal Checklist
- Project Progress Meetings and Site Visits
- AIS Certification and Submittal Review
- Labor Interviews
- Pay Requests and Certified Payroll
  - The Consultant shall log, review, and evaluate the certified payroll submitted by the Contractor, provided by the Engineer-of-Record, and evaluate compliance with the applicable prevailing wage rates.
  - Utilizing the City's selected software, LCP Tracker, to monitor the certified payroll progress.
- Loan Disbursement Requests
  - As work progresses, the Consultant shall prepare and submit Loan Disbursement Requests on a bi-monthly basis, and one final disbursement request upon Final Completion of the Project.
- SRF Project Closeout
- Interfacing with Florida Rural Water construction inspectors.



**Client**

City of Pompano Beach

**Scope of Services**

Membrane pilot testing, permitting, preparation of contract documents for direct procurement of membranes as well as membrane element loading, bidding, contract administration, on-site observation during loading, and review of membrane performance testing.

**Contact**

Mr. Phil Hyer  
 Utilities Treatment Plants  
 Superintendent  
 City of Pompano Beach  
 1205 N.E. 5<sup>th</sup> Avenue  
 Pompano Beach, FL 33061  
 954.545.7030  
 Phil.hyer@copbfl.com

**Start Date**

03/2016

**Completion Date**

05/2020

**Construction Cost**

\$1.098 million

**Change Orders**

None

**Key MBC Staff**

Frank A. Brinson, P.E.  
 Andrew H. Barba, P.E.

**Benefit to the City**

Reduced feed pressure and elimination of chemical pretreatment resulted in a realized annual operating cost savings of \$600,000.

## Nanofiltration Pilot Testing and Membrane Element Replacement

### Pompano Beach, Florida



## Background

The City of Pompano Beach owns and operates a 50 million gallon per day (mgd) capacity water treatment plant (WTP) which consists of a 10 mgd capacity nanofiltration (NF) process in parallel with a 40 mgd conventional lime softening process. The NF process includes five 2 mgd NF units arranged in a two-stage, 36:16 array, and the system was designed to operate at an 85% recovery rate. The NF units were populated with a hybrid of 1,820 membrane elements (Hydranautics models ESNA1-LF and ESNA1-LF2), which were installed in 2009. NF membrane elements typically have a useful service life of 5 to 7 years. In 2016, the City was ready to begin pilot testing to prepare for replacing the membrane elements that were installed in 2009.

## The Project

In preparation for the membrane element replacement, the City and MBC designed, permitted, and constructed a pilot unit that utilized three full-size (8-inch diameter, 7-element) pressure vessels in a 2:1 array with independent cartridge filters and pre-

## Nanofiltration Pilot Testing and Membrane Element Replacement

Pompano Beach, Florida

treatment chemical feed systems. The pilot unit was permitted to withdraw feedwater from the NF process raw water header and discharge permeate and concentrate to the full-scale plant's respective headers.

MBC assisted the City in requesting letters of interest (LOI) from three leading NF membrane element manufacturers (MEMs): Hydranautics, Dow Water and Process Solutions, Inc. (Dow), and Koch Membrane Systems, Inc. The City received affirmative responses from Hydranautics and Dow.

Membrane element selections from both MEMs were pilot tested in two phases:



*Full Size 8-inch Pilot Unit*

- Phase 1 was aimed at confirming that MEM's proposed membranes would meet the specified permeate quality and membrane performance requirements under the current operating conditions of full-scale NF process (i.e., with acid and antiscalant chemical pretreatment). Meeting the specified permeate quality and membrane performance requirements during this phase of testing constituted prequalification of the MEM's proposed membranes for the full-scale membrane re-load. Both MEM's were successfully prequalified for the full-scale membrane replacement.
- Phase 2 of the testing was conducted to evaluate the performance of the membrane element selections and potential long-term fouling tendencies under modified operating conditions and with no chemical pretreatment (acid and antiscalant pretreatment were eliminated during Phase 2).



*New membrane elements*

As noted above, both MEM's were prequalified during the Phase 1 testing. The Phase 2 testing was successful in demonstrating stable operation with no chemical pretreatment, and the City made the decision to proceed with the full-scale membrane replacement with no chemical pretreatment in the full-scale plant. In May 2019 the City advertised for bids for the membrane element replacement. Hydranautics was the successful low bidder, and the City issued a notice to proceed in December 2019.

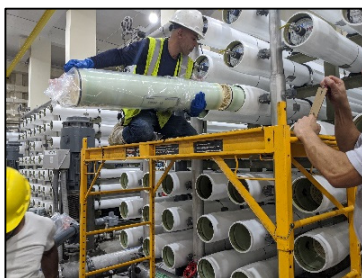

*Membrane element loading*

The initial hybrid membrane arrangement was consistent with the pilot unit (first-stage: 7 ESPA 4-LD elements, second-stage: 7 ESNA-LF2-LD elements). However, during the start-up performance acceptance testing of the first full-scale NF unit, it was found that this loading configuration did not meet the specified permeate quality requirements. Hydranautics modified the loading configuration, as allowed in the contract.

The modified loading configuration allowed the full-scale NF process to meet specified performance and permeate quality requirements, with no acid and antiscalant chemical pretreatment. The project was completed in May 2020, six months ahead of schedule with no change orders.

# Nanofiltration Pilot Testing and Membrane Element Replacement

Pompano Beach, Florida

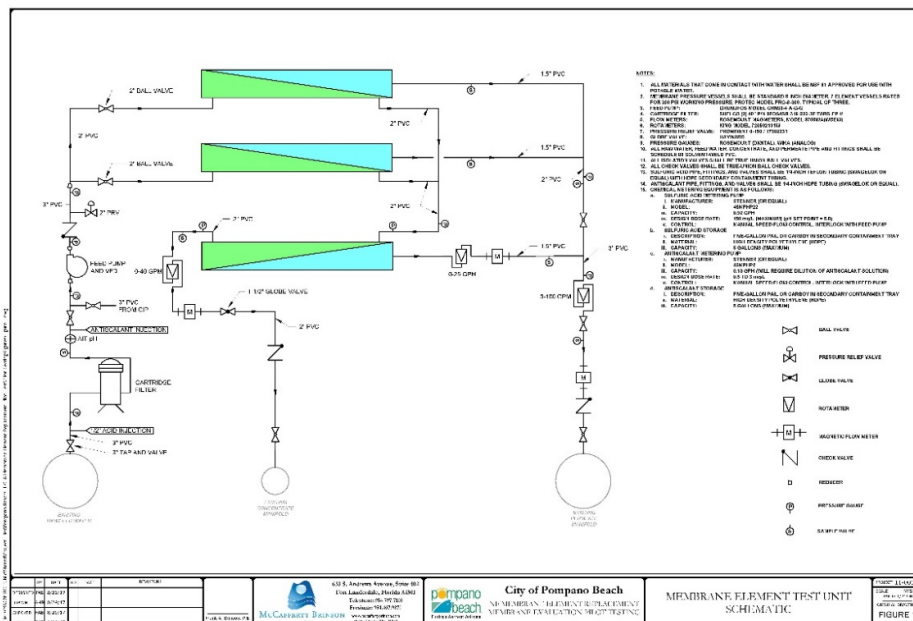

At start-up, the average feed pressure of the NF units was 73 psi with the new membrane elements, approximately 17 psi lower than the start-up pressure of the City’s previous membrane elements. As of March 2024, the new membrane elements have been in service for four years with no chemical pretreatment, meeting all water quality goals, and with two routine cleanings to-date. The elimination of acid and antiscalant chemical pretreatment, coupled with the reduction in feed pressure, resulted in a realized total annual operating cost savings to the City of \$600,000.

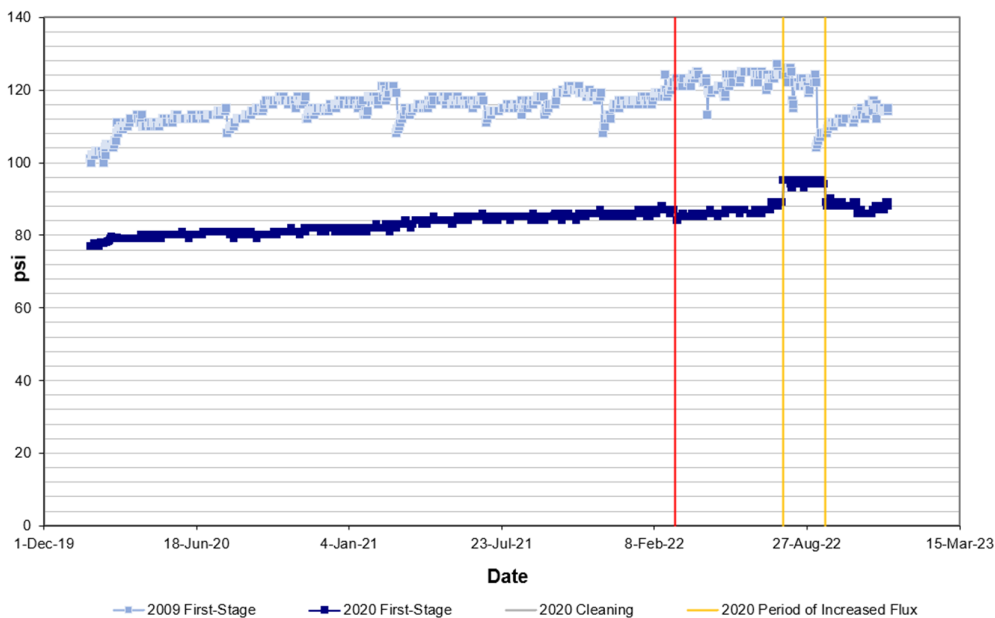

Comparison of Start-Up Feed Pressure: 2009 vs. 2020

**Client**

City of Boca Raton

**Scope of Services**

Preparation of construction drawings and technical specifications, permitting, bidding, and engineering services during construction.

**Contact**

Justin Barrington, P.E.  
 Deputy Director  
 City of Boca Raton  
 1401 Glades Road  
 Boca Raton, Florida 33487  
 561.338.7382  
 jbarrington@myboca.us

**Start Date**

March 2019

**Completion Date**

March 2025

**Construction Cost**

\$3.4 million

**Key MBC Staff**

Frank A. Brinson, P.E.  
 Andrew Barba, P.E.  
 Mathew Marsh, P.M.P

**Key Features**

Pressure filter system provides pretreatment of membrane feed water for 40-mgd NF process.

**Benefit to the City**

Pressure filter system removes particulate and colloidal foulants from the feedwater, extending the service lives of the cartridge filters and NF membrane elements and improving overall process efficiency and reliability.

## Membrane Pretreatment Pressure Filter System Expansion Boca Raton, Florida



### Background

The City of Boca Raton owns and operates a nanofiltration (NF) membrane water treatment facility with a capacity of 40 million gallon per day (mgd). Pretreatment of the NF feedwater includes a granular media pressure filtration system consisting of four two-cell steel pressure filter vessels upstream of the cartridge filters and the membrane process. Prior to implementation of this project, the pressure filters were the capacity-limiting component of the NF treatment process. The original designed hydraulic loading rate on the pressure filters has proven to be difficult to maintain for extended periods of time, requiring frequent filter backwashing with the associated filter cell down-time.

The City elected to expand the capacity of the existing pressure filter system by 50% through the addition of two new 10-foot diameter by 41-foot long, two-cell steel pressure filters that are similar in design to the existing pressure filters, with all required internals, face piping, fittings, valves, electric valve operators, electrical systems, instrumentation, and controls. The expansion allows the NF process to be operated at the full 40-mgd rated capacity, without excessive pressure filter backwashing, while reducing the particulate loading on the downstream membrane pretreatment 5-micron cartridge filters. The design of the new pressure filter system included numerous upgrades from the existing system, including a more robust underdrain system design and media-retaining launders, while the operation of the new filters is seamlessly integrated into the existing filter system.

## Membrane Pretreatment Pressure Filter System Expansion

Boca Raton, Florida

### The Project

MBC's scope of services included design, permitting, bidding, and construction contract administration for the addition of two pretreatment pressure filters including all civil, mechanical, instrumentation and controls, and electrical upgrades required for a complete and operating system. MBC's scope of works for the project included the following:

- Preparation of construction drawings, technical specifications, and opinions of probable construction cost at the 30%, 70%, and 100% stages of design development.
- Procurement of a Permit to Construct Public Water System (PWS) Components from the Florida Department of Health in Palm Beach County Permit (FDHPBC).
- Bidding services.
- Engineering services during construction including contract administration, review of shop drawings, pay applications, and other submittals, responding to Contractor's requests for information, periodic project meetings and site visits, resident project representative (RPR) services, milestone inspections, start-up, testing, operator training, and close-out.

The contract for construction of the project was awarded to RJ Sullivan Corporation with a Notice to Proceed issued September 9, 2021. The project was completed in March 2025.

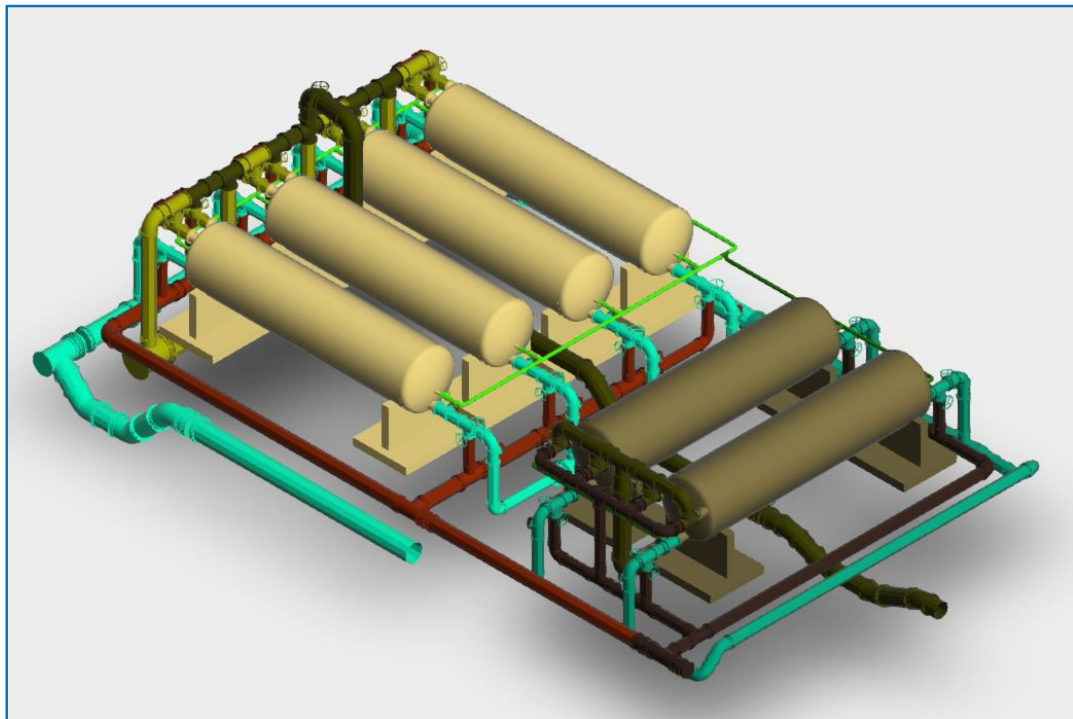

Model developed during design showing integration of the new filters into the existing system.

**Client**

City of Pompano Beach

**Scope of Services**

Design development and preparation of construction documents for buildout of the City's existing NF facility, a second concentrate deep injection well, a new reverse osmosis treatment facility, and decommissioning of the existing lime softening process to comply with the USEPA NPDWR for PFAS.

**Contact**

Mr. Phil Hyer  
 Utilities Treatment Plants  
 Superintendent  
 City of Pompano Beach  
 1205 N.E. 5<sup>th</sup> Avenue  
 Pompano Beach, FL 33061  
 954.545.7030  
 Phil.hyer@copbfl.com

**Start Date**

November 2024

**Completion Date**

Ongoing

**Key MBC Staff**

Frank A. Brinson, P.E.  
 Andrew H. Barba, P.E.  
 Audra McCafferty, P.E.

**Key Features**

- Evaluation of raw water supply and wellfield.
- Pilot testing of NF membrane elements and pretreatment technologies.
- Development or preliminary design report, corrosion control study, and construction documents.
- Funding administration and assistance.

**Benefit to the City**

Expedited design development enabled the City to secure \$46.2 million (with 25% principal forgiveness) in SRF loan funding for construction of timely compliance with PFAS regulations.

# Water Treatment Plant Improvements Program: Emerging Contaminants (PFAS) Pompano Beach, Florida

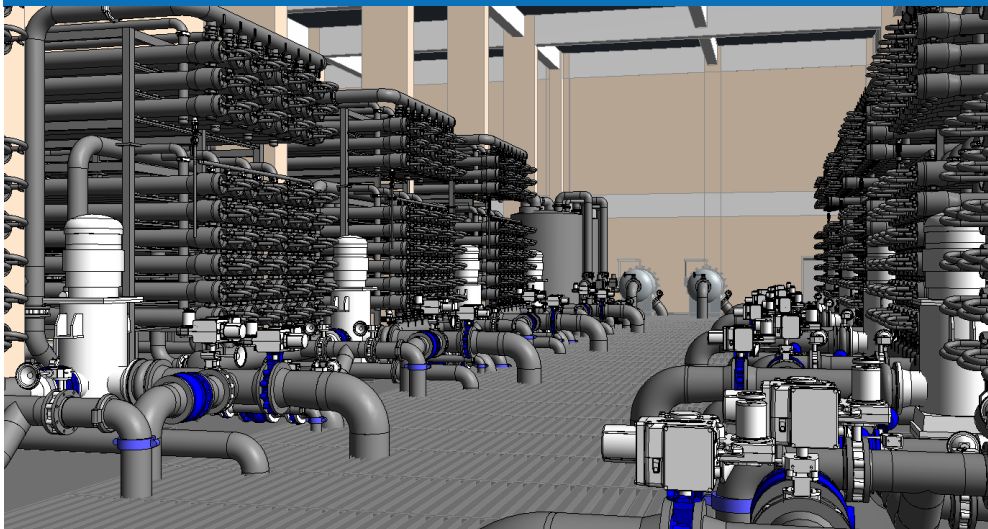

## Background

The Pompano Beach Water Treatment Plant (WTP) utilizes a combination of conventional lime softening (40 mgd) and nanofiltration (NF) membrane treatment (10 mgd) to produce the City's blended finished water supply.

In March 2023, the United States Environmental Protection Agency (USEPA) proposed a National Primary Drinking Water Regulation (NPDWR) for certain per- and polyfluoroalkyl substances (PFAS) with an estimated compliance date of April 2029. The 2021 Bipartisan Infrastructure Law (BIL) established an Emerging Contaminants funding source, from which Federal grant funds were made available to drinking water utilities for implementation of water treatment plant upgrades that are necessary to provide compliance with the proposed PFAS regulations. As with nearly all utilities in South Florida who utilize conventional lime softening treatment of the surficial Biscayne Aquifer raw water supply, the Pompano Beach WTP will require substantial upgrades to comply with the proposed PFAS regulations. After assisting the City with securing a planning/design grant (loan with 100% principal forgiveness) in the amount of \$9,595,000 and preparing the Water Facilities Plan for Emerging Contaminants Water Treatment Plant Upgrades, McCafferty Brinson Consulting, LLC (MBC) was authorized by the City to proceed with the design of the recommended, most cost-effective, alternative from the Water Facilities Plan, under the Water Treatment Plant Improvements Program.

## The Projects

The projects included under the Water Treatment Plant Improvements Program can be described by the following phases:

- **Phase 1** – Design and construction of a 15 to 20 million gallon per day (mgd) capacity buildout of the City’s existing NF facility (a total capacity of 25 to 30 mgd), which was originally designed to be expandable to 20 to 22 mgd total capacity. The Phase 1 improvements include a modification to the City’s existing raw water allocations from the surficial Biscayne Aquifer under the City’s current Water Use Permit (WUP) with the South Florida Water Management District (SFWMD). This phase includes addition of a raw water booster pump station, physical pretreatment systems (sand strainers or pressure filters, to be determined by pilot testing, and cartridge filters), demolition and removal of the existing five 2 mgd membrane units (pumps, valves, appurtenances, and associated piping), installation of ten 3 mgd membrane units (pumps, valves, appurtenances, and associated piping), and post-treatment systems (three additional degasifiers).

Engineering services provided by MBC and their subconsultants associated with this phase include the following tasks:

- **Raw Water Characterization, System Evaluation, and Improvements:** The City’s existing NF facility is fed from the City’s western wellfield. Increasing the capacity of the NF facility to 25 to 30 mgd requires the use of the City’s existing eastern wellfield which currently feeds the existing lime softening process. Because this is a new raw water supply for the NF facility, it is necessary to evaluate the raw water quality and treatability requirements of the eastern wellfield supply for the build out of NF facility. Additionally, the mechanical design, materials of construction, and condition of the raw water pumping and transmission system of the eastern wellfield were evaluated because of their substantial impacts on the viability, operating stability, reliability, and treatment efficiency of the NF facility. MBC and the City are currently working to condition the eastern wellfield supply by flushing the system and by implementing recommended improvements associated with the evaluation.
- **Pilot Testing:** Due to the changes to the raw water supply needed for increasing the capacity of the NF facility (described above), the City is testing a composite blend of water from the eastern and western wellfields at similar ratios to that of the full-scale process. This testing is necessary to confirm that the new composite blend can be treated similarly to the City’s existing NF process (i.e. without chemical pretreatment) and to select suitable physical pretreatment (sand strainers or pressure filters). MBC and the City are currently evaluating physical pretreatment technologies utilizing the City’s existing membrane pilot unit.
- **Corrosion Control Study:** The buildout of the NF facility, and ultimately the decommissioning of the lime softening process (Phase 2A, described herein), will impact the corrosion control requirements of the City’s finished water. MBC and their subconsultants prepared a desk-top corrosion control study to determine the optimal corrosion control treatment for the treated finished water. MBC and the City are collecting pipe materials and appurtenances from the City’s distribution system to prepare for pipe loop and coupon testing to confirm the findings of the desk-top analysis.

- **Construction Document Preparation:** MBC and their subconsultants have prepared and delivered construction drawings, specifications, and opinion of probable construction costs at the 30%, 60%, and permit set stages of design development. These documents are considered biddable and have been submitted to the Florida Department of Environmental Protection (FDEP) State Revolving Fund (SRF) for consideration for construction phase funding at the August 2025 priority list meeting.
- **Preliminary Design Report (PDR) and Permitting:** As required by the Florida Administrative Code, MBC and their subconsultants prepared a PDR for submittal to the FDEP as part of the Application for a Specific Permit to Construct PWS components. The PDR and application were submitted to the FDEP and a Notice of Permit Issuance was provided in July 2025, with no requests for additional information.
- **Funding Assistance:** In addition to provide planning and design phase SRF administration services (coordination with SRF, preparation and transmittal of disbursement requests), MBC assisted the City with securing two SRF loans at the August 2025 priority list meeting: \$30,000,000 (with 20% principal forgiveness) for the construction of the Phase 1 project and \$16,200,000 (with 35% of principal forgiveness) for the construction of Phase 1A.

Phase 1 of the program is expected to be completed in the first quarter of 2026, and construction is anticipated to commence in the third quarter of 2026.

- **Phase 1A** – Design and construction of a second concentrate disposal deep injection well (DIW). Design phase services associated with this phase were performed concurrently with Phase 1 and include construction document preparation, permitting, and funding assistance engineering services as described above. Engineering services included under Phase 1A are completed and construction is anticipated to commence in the first quarter of 2026.
- **Phase 2** – If the SFWMD does not approve modifications to the City’s existing raw water allocations from the surficial Biscayne Aquifer under the City’s current WUP, engineering services similar to those under the Phase 1 project will be performed to design a reverse osmosis membrane treatment facility with a capacity as required to achieve the 30 mgd total treatment capacity.
- **Phase 2A** – Upon construction completion of Phase 1 (and Phase 2, if required), MBC and their subconsultants will prepare construction documents for the decommissioning, demolition, and removal of the City’s existing lime softening process.

By implementing the projects described herein under the Water Treatment Plant Improvements Program, the City is on target to comply with the USEPA NPDWR for PFAS by the current compliance date, April 2029.

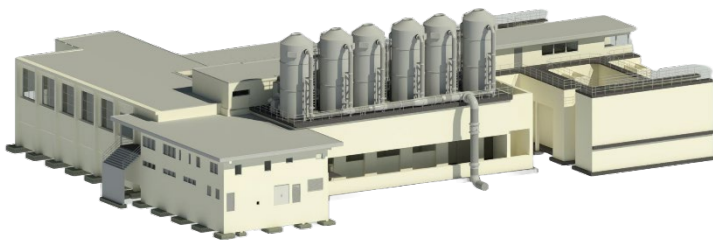

*Degasifiers and Filter Building*

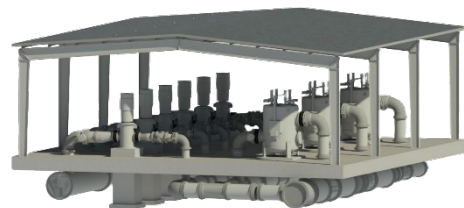

*Raw Water Booster Pump Station*

**Client**

City of Pompano Beach

**Scope of Services**

Design, preparation of construction drawings technical specifications, permitting, bidding services, and construction administration.

**Contact**

Mr. Phil Hyer  
 Utilities Treatment Plants  
 Superintendent  
 City of Pompano Beach  
 1205 N.E. 5th Avenue  
 Pompano Beach, FL 33061  
 954.545.7030  
 Phil.hyer@copbfl.com

**Start Date**

02/2018

**Completion Date**

09/14/2022

**Construction Fee**

\$ 2.024 million

**Key MBC Staff**

Frank A. Brinson, P.E.  
 Andrew Barba, P.E.  
 Robert Landrum, E.I.  
 Mathew Marsh, P.M.P.

**Key Features**

Design services for removal and replacement of valves, actuators, modifications to bypass piping, and additive alternates to modify filter feed and lower pressure distribution pump systems.

## Reuse Water Treatment Plant Modifications Design and Construction Pompano Beach, Florida



### Background

The City of Pompano Beach owns and operates a 7.5 million gallon per day (mgd) capacity reuse water treatment plant (RWTP) which treats effluent from the Broward County Water and Wastewater Services (BCWWS) North Regional Wastewater Treatment Plant (NRWWTP), withdrawing from the ocean outfall pipeline. The Pompano Beach RWTP produces reuse water suitable for public-access irrigation, and serves the City's municipal golf course, as well as residential areas within the City's service area. The plant has experienced difficulties in meeting reclaimed water demands due to elevated feedwater turbidity, stemming from construction activities at the BCWWS NRWWTP, which are beyond the City's control. To continue to meet reuse water demands and maintain the existing viable customer users, the City desired to make near-term and long-term improvements and modifications at the reuse water treatment plant.

## The Project



*New fill piping*

The proposed improvements and modifications included the following:

- Installation of piping to allow the reclaimed water storage tanks to be filled with potable water to supplement the reclaimed water production during periods when the plant's production cannot meet demands. Piping will include appropriate accessories (e.g., flow metering, backflow prevention, etc.).
- Removal and replacement of existing valves and actuators.
- Modifications to existing filter bypass return piping.
- Addition of two new filter feed pumps in existing pump suction barrels.
- Removal and replacement of three existing and the addition of two new low pressure distribution pumps in existing pump suction barrels.

MBC's scope of services included design, preparation of construction drawings and technical specifications, permitting, and bidding services to implement the improvements and modifications outlined above. The design, permitting, and installation of the potable water storage tank fill piping was completed in May 2018.

The remaining improvements were included in a contract for construction that was awarded to Florida Design Drilling Corporation in December 2020. MBC provided contract administration services during construction. The project final completion date was September 14, 2022, on-time and with no change orders.

**Client**

City of Pompano Beach

**Scope of Services**

Professional engineering services for preparation of a needs assessment and conceptual design.

**Contact**

Mr. Phil Hyer  
 Utilities Treatment Plants  
 Superintendent  
 City of Pompano Beach  
 1205 N.E. 5<sup>th</sup> Avenue  
 Pompano Beach, FL 33061  
 954.545.7030  
 phil.hyer@copbfl.com

**Start Date**

11/2018

**Completion Date**

03/2020

**Key MBC Staff**

Frank A. Brinson, P.E.  
 Andrew Barba, P.E.  
 Robert Landrum, E.I.

**Key Features**

Evaluation of existing filter system needs, identification and evaluation of alternate treatment technologies, preliminary opinions of probable project and operating costs.

**Benefit to City**

Keeping the City at the forefront on treatment technologies.

## Gravity Filter Refurbishment and Alternative Treatment Technology Study

### Pompano Beach, Florida



## Background

The City of Pompano Beach owns and operates a 50 million gallon per day (mgd) capacity water treatment plant which utilizes a combination of conventional lime softening (40 mgd) and nanofiltration membrane treatment (10 mgd). The conventional lime softening process stream includes a multimedia gravity filtration system downstream of the lime softening units. The gravity filter system was constructed in 1983 and is exhibiting signs of age, deterioration, and is in need of repair and refurbishment. The City authorized MBC to conduct an engineering evaluation of the performance and condition of the gravity filter system (filters seven through fourteen) to determine specific repair and rehabilitation needs in preparation for a gravity filter refurbishment project. Additionally, under this study, MBC was authorized to identify and evaluate alternate treatment technologies to potentially replace the gravity filter system.

## The Project



The City authorized MBC to provide professional engineering services to complete a study that evaluated the existing gravity filter system and the feasibility of implementing alternate treatment technologies.

MBC's scope of services for the project included the following:

- Evaluation of Existing Filter System Needs
- Identification and Evaluation of Alternate Treatment Technologies
- Preliminary Opinions of Probable Project and Operating Costs
- Preparation of Draft and Final Study Reports

The Final Report was delivered to the City in March 2020 and provided treatment and cost analyses associated with rehabilitating the existing gravity filter system, implementing three separate alternate treatment technologies in the existing gravity filter basins, and expanding the Nanofiltration process.

**Client**

City of Pompano Beach

**Scope of Services**

Evaluation and development of a conceptual phasing plan for expansion of the city's existing 10.0 mgd nanofiltration process to an ultimate capacity of 30 mgd, including phasing out the existing lime softening process.

**Contact**

Mr. Phil Hyer  
Utilities Treatment Plants  
Superintendent  
City of Pompano Beach  
1205 N.E. 5<sup>th</sup> Avenue  
Pompano Beach, FL 33061  
954.545.7030  
Phil.hyer@copbfl.com

**Start Date**

11/2020

**Completion Date**

09/2021

**Key MBC Staff**

Frank A. Brinson, P.E.  
Andrew H. Barba, P.E.

**Key Features**

- Evaluation of capacities of existing treatment process components.
- Development of conceptual expansion phasing plan.
- Development of preliminary opinion of probable construction costs.

**Benefit to the City**

Document serves as a roadmap for cost-effective compliance with pending emerging contaminants regulations.

# Nanofiltration Process Expansion Study

City of Pompano Beach  
September 2021



## Background

The City of Pompano Beach (City) owns and operates a 50 million gallon per day (mgd) capacity water treatment plant which utilizes a combination of conventional lime softening (LS) (40 mgd) and nanofiltration (NF) membrane treatment (10 mgd). The NF treatment system consists of four pre-treatment cartridge filters, five 2.0 mgd permeate capacity membrane units, three post-treatment degasifiers and associated piping, valves, controls, electrical gear, concentrate disposal, and support infrastructure.

The NF plant was originally designed to accommodate future expansion to a total capacity of 20 mgd through the addition of five membrane units and associated equipment within the existing building. The City was interested in evaluating the existing process systems and plant infrastructure to develop a detailed plan for completing a cost-effective expansion of the NF process to the maximum capacity that can be supported by the existing major infrastructure (e.g., within the existing building) in a phased manner.

### The Project

MBC's scope of services for the project included the following:

- Development of a phased expansion plan, schedule, and preliminary opinion of probable construction cost for the build-out of City's NF Process.
- Preparation of conceptual level drawings, schematics, and figures to illustrate proposed phasing plan.
- Evaluation of the feasibility of constructing a new NF process building that provides an additional 10.0 mgd of treatment capacity.

The final report was delivered to the City in September 2021, presenting a phased plan for the cost-effective expansion of the NF process to a total capacity of 30 mgd, and decommissioning of the existing lime softening process.

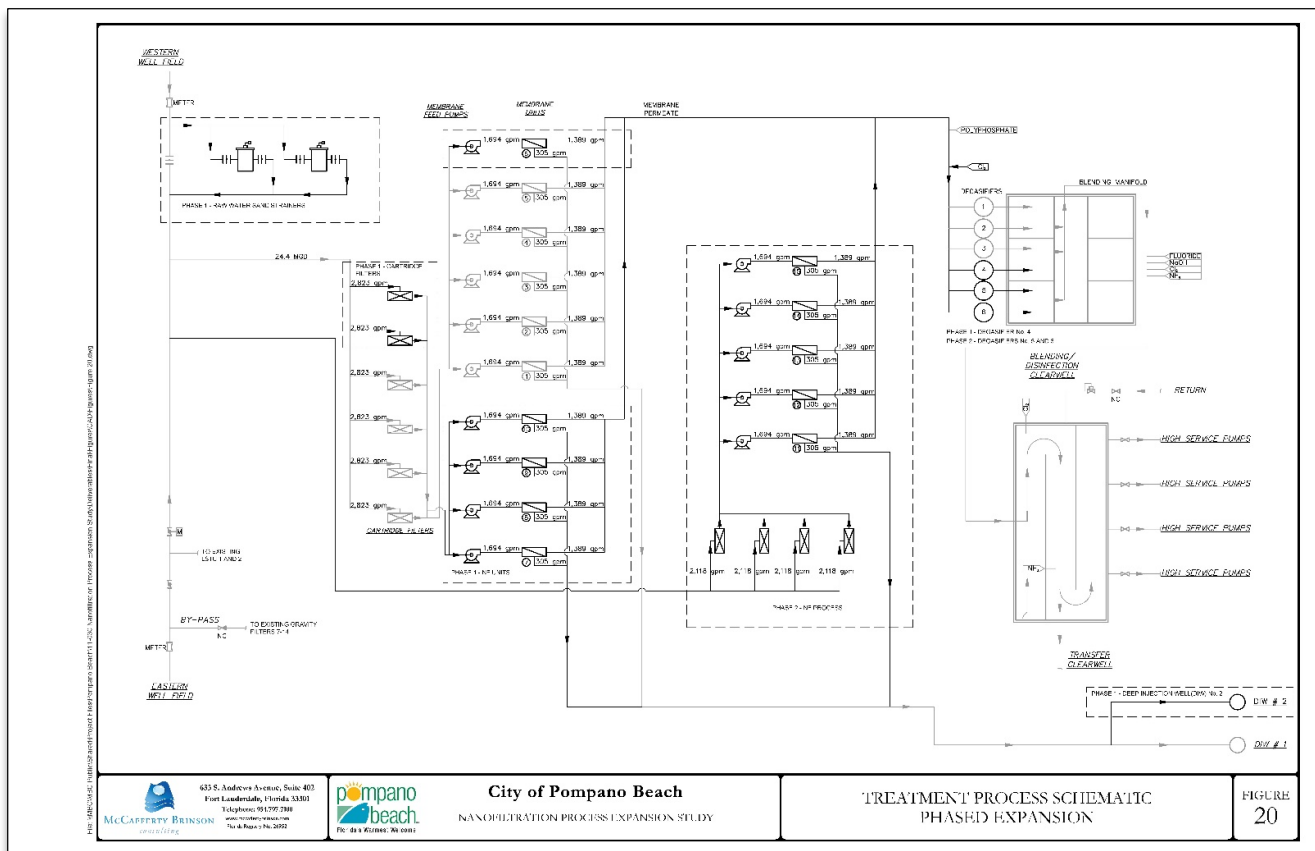

**Client**

City of Boca Raton

**Scope of Services**

Professional engineering services for preparation of a needs assessment and conceptual designs.

**Contact**

Lauren M. Burack, P.E.  
 Capital Improvement Project  
 Manager  
 City of Boca Raton  
 1401 Glades Road  
 Boca Raton, Florida 33487  
 561.866.7193  
 lburack@myboca.us

**Start Date**

Membrane Study - 08/2020  
 Lime Study - 11/2018

**Completion Date**

Membrane Study - 01/2022  
 Lime Study - 08/2019

**Key MBC Staff**

Frank A. Brinson, P.E.  
 Audra McCafferty, P.E.  
 Andrew Barba, P.E.

**Key Features**

Project included investigation and evaluation of the current condition of treatment process systems and equipment associated with the lime and membrane softening processes, as well as support systems and plant infrastructure to determine needed improvements.

**Benefit to the City**

The City has utilized these reports as a basis for rehabilitating and modifying the structures and equipment associated with both treatment processes.

## Membrane and Lime Softening Process Renovation Needs Studies

Boca Raton, Florida



### Background

The City of Boca Raton Glades Road Water Treatment Plant is a 70 million gallon per day (mgd) capacity facility that utilizes a combination of conventional lime softening (30 million gallons per day (mgd) capacity) and membrane softening (40 mgd capacity) to treat raw water from the Biscayne Aquifer.

The lime softening treatment process includes a chemical building (Building 11) that houses the lime storage silos, lime slakers, lime feed equipment, a coagulant storage, preparation, and feed system, as well as other associated supporting systems and functions. Building 11 was constructed in the early 1970s and is in need of hurricane-hardening (specifically the lime silos) and renovation. The renovation will remove existing, out-of-service equipment and optimize the existing chemical processes, electrical systems, and the overall functions of the building.

The City authorized MBC to complete a comprehensive study of Building 11 to determine what upgrades are needed to hurricane-harden the building and silos, rehabilitate the building, modernize and upgrade the chemical handling, processing, and feed systems, and consolidate and optimize the electrical systems.

## Membrane and Lime Softening Process Renovation Needs Studies

Boca Raton, Florida



*Lime Slaker Units*

The membrane softening treatment process was constructed in 2004 and consists of an on-site raw water booster pump station, a multimedia pretreatment pressure filtration system, the main membrane softening process building, permeate degasifiers, an off-gas odor control system, and the permeate clearwell and transfer pumping system. The membrane softening process building houses the main components of the treatment system: cartridge filters, high-pressure membrane feed pumps, membrane softening units, a permeate flush system, a membrane cleaning system, a membrane process control room, and associated structural, HVAC, electrical, and control systems. Since start-up of this process the City has replaced the membrane elements (2015) and rehabilitated the pressure filters (2019).

The City authorized MBC to evaluate membrane softening process equipment, support systems and associated structural members to determine the most efficient and strategic way to complete future rehabilitation projects. Additionally, MBC evaluated design upgrades to improve operational flexibility, process efficiency, and overall reliability of the membrane softening process.

### The Project

MBC was authorized to prepare comprehensive Needs Studies and evaluate potential design modifications and improvements for both the lime softening and the membrane softening processes. The scope of work provided under these studies included the following:

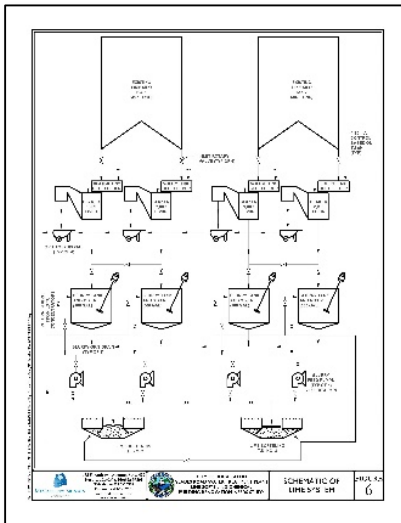

- Structural evaluation of the integrity of the building and associated structures and equipment, including the two 497-ton capacity steel lime silos.
- Identification of structural needs, design criteria, and standards applicable for process/mechanical systems, including a hurricane hardening analysis.
- Identification of treatment process/mechanical functions provided by the building and determination of needed improvements for the renovation
- Identification of potential process and system upgrades for consideration by the City to address process or operational issues that have been recognized by operating staff since the plant was placed on-line.
- Identification of age-related deficiencies that require renovation and rehabilitation to maintain reliable, efficient, and cost-effective operation.
- Evaluation of alternatives for upgrading and/or consolidating the electrical systems to improve efficiency reliability and identification of design criteria and standards applicable to the potential electrical modifications.
- Development of conceptual designs for implementation of the recommended improvements to address the identified deficiencies and potential upgrades.
- Development of a conceptual program of projects (e.g., bid packages) to implement the design recommendations, including preliminary opinions of cost, preliminary schedules, and construction sequencing requirements.

**Client**

City of Boca Raton

**Scope of Services**

Professional engineering services for preparing construction drawings, technical specifications, opinion of probable cost, permitting services, bidding services, resident project representative services, and construction administration.

**Contact**

Justin Barrington, P.E.  
 Deputy Director  
 City of Boca Raton  
 1401 Glades Road  
 Boca Raton, Florida 33487  
 561.338.7382  
 jbarington@myboca.us

**Start Date**

09/2020

**Completion Date**

7/2025

**Key MBC Staff**

Frank A. Brinson, P.E.  
 Andrew Barba, P.E.  
 Mariell Soto, P.E.

**Key Features**

Project includes a comprehensive renovation of Buildings 5 and 6, and upgrades to the transfer pumping system in Building 7.

**Benefit to the City**  
 Renewal and repair of aged equipment, upgraded operational flexibility with redundancy and reliability.

## Transfer Pumping Upgrades at the Water Treatment Plant Design

### Boca Raton, Florida



## Background

The City of Boca Raton is supplied with potable water from the Glades Road Water Treatment Plant, a 70 million gallon per day (mgd) facility that utilizes 30 (mgd) capacity conventional lime softening process in parallel with a 40 (mgd) nanofiltration (NF) process. The treated finished water from these two processes is blended and pumped to the on-site finished water storage tanks using two transfer pumping systems located in Building 5 and Building 7. Each building currently houses three (3) vertical turbine transfer pumps for a total of six (6) transfer pumps.

Building 5 was originally constructed in 1981 along with the installation of two vertical turbine transfer pumps with space for two additional future pumps. The pumps transfer flow from a below grade clearwell. Power and controls for Building 5 are provided by the electrical room in Building 6. Buildings 6 and 7 were constructed in 1991 under a project that also included the addition of a third transfer pump in Building 5. Building 7 has the additional three (3) transfer pumps which were installed in 2001 under the membrane softening process addition project. The transfer pumping systems and the structures and associated support systems in Buildings 5 and 6 described above are in need of rehabilitation and upgrade.

## The Project



*Transfer Pumps*

In general, the project involves the replacement and upgrade of mechanical, electrical, structural, architectural, and plumbing systems within Buildings 5, 6 and 7. The project includes replacing pumps, motors, valves, and piping. Additionally the project involves upgrading electrical systems, such as MCCs, feeder cables, and switchgear; and enhancing SCADA monitoring with temperature and vibration sensors. Structural improvements include hurricane hardening doors and windows, replacing roofs, repairing concrete curbs, and coating interior walls and floors. Additionally, the project will enhance pedestrian access, upgrade drainage and ventilation systems, improve exterior aesthetics with new stucco and paint, and ensure compliance with hurricane-rated and plumbing standards.

The scope of MBC's services on the project includes the following:

- Replacement of the mechanical components of the transfer pump system in Building 5 including three pumps, motors, and all piping components and accessories between the existing pump suction and the discharge risers, with the addition of a fourth pump.
- Replacement of all valves in Building 5 and 7, including isolation valves, check valves, and air valves.
- Replacement of sample pump(s) and piping with a drain connection to the sewer system.
- Relocation of the ammonia injection system for continued plant operations during construction.
- Elimination of the dump valve, actuator, and wiring; plugging of the pipe entrance into the clearwell, and demolition of the exterior vault, grate, and actuator.
- Replacement of chemical pipe trench covers with heavier-duty ones to support lawn care equipment.
- Upgrading of the crane system in Building 5 by replacing the manual hoist and bridge mechanism while retaining the steel I-beams.

This project design phase is complete and the project is anticipated to bid in the first quarter of 2026.



#### Client

Broward County Water and  
Wastewater Services (BCWWS)  
MBC Subconsultant to Prime  
Consultant

#### Scope of Services

Professional engineering  
services to identify and evaluate  
treatment technology alternatives  
to comply with proposed PFAS  
regulations at the District 1A and  
2A Water Treatment Plants.

#### Contact

Mr. Alan Garcia  
Director  
Broward County Water and  
Wastewater Services  
2555 West Copans Road  
Pompano Beach, FL 33440  
agarcia@broward.org  
954.831.0704

#### Start Date

August 2023

#### Completion Date

March 2024

#### Key MBC Staff

Frank A. Brinson, P.E.  
Andrew Barba, P.E.  
Mariell Soto, P.E.

#### Key Features

Project included identification of  
appropriate treatment technology  
alternatives, development of  
conceptual design options for  
each treatment plant and capital  
cost estimates, and  
recommendations for the most  
effective approach at each facility.

## PFAS Water Treatment Impact Assessment Broward County, Florida

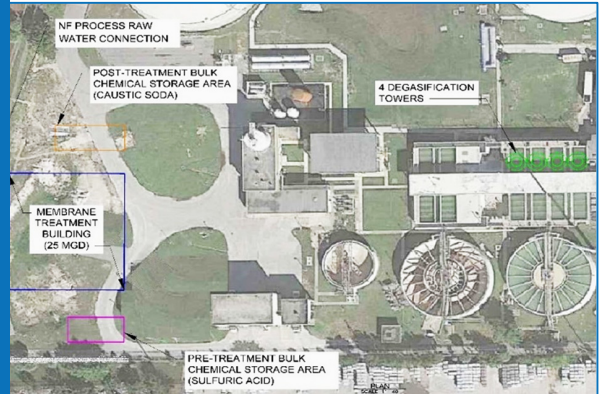

## Background

PFAS represents a group of thousands of synthetic chemicals that persist in the environment because they do not readily degrade. The United States Environmental Protection Agency (USEPA) has proposed a National Primary Drinking Water Regulation (NPDWR) for certain identified per- and polyfluoroalkyl substances (PFAS) with an estimated compliance date for the proposed PFAS NPDWR of December 2026. BCWWS has identified the presence of certain PFAS constituents in the raw water supplies for the County's two water treatment plants (District 1A and District 2A) as levels that exceed the proposed maximum contaminant levels (MCLs) for the proposed regulated PFAS constituents. Both water treatment plants use conventional lime softening, granular gravity filtration, and disinfection for their treatment processes. These technologies do not provide significant removal of PFAS. Consequently, the current finished water quality will not comply with the proposed regulations, and both water treatment plants will require treatment process upgrades to comply with the proposed regulations. The USEPA has identified three treatment technologies as the "best available technologies" (BAT) for the removal of PFAS in drinking water supplies: membranes (nanofiltration, NF, and reverse osmosis, RO), granular activated carbon (GAC), and anion exchange (AIX).

## The Project

The County retained an engineering team, including McCafferty Brinson Consulting, LLC (MBC), to conduct a conceptual-level evaluation of potential NF, GAC, and AIX upgrades at each of the County's plants. This assessment was intended to chart the County's course to further refine and implement improvements required to meet the proposed PFAS regulations. The scope of services included the development of conceptual designs and layouts, conceptual-level cost estimates, and the identification and evaluation of subjective considerations for each technology alternative, such as residuals disposal issues and adaptability of the technology to other currently unregulated emerging contaminants. MBC was responsible for all components of the study scope related to the membrane (NF) alternatives at each facility.

**Client**

City of Boca Raton

**Scope of Services**

Professional engineering services for preparing construction drawings, technical specifications, opinion of probable cost, permitting services, bidding services, resident project representative services, and construction administration.

**Contact**

Justin Barrington, P.E.  
Deputy Director  
City of Boca Raton  
1401 Glades Road  
Boca Raton, Florida 33487  
561.338.7382  
jbarrington@myboca.us

**Start Date**

03/2018

**Completion Date**

November 2024

**Construction Cost**

\$ 4.99 million

**Key MBC Staff**

Frank A. Brinson, P.E.  
Andrew Barba, P.E.  
Mathew Marsh, P.M.P.

**Key Features**

Project included design of a washwater recovery basin, supernatant decanting system, settled sludge handling, and a washwater return pumping system. The project also included yard piping improvements, electrical improvements, associated sitework and instrumentation and controls.

**Benefit to the City**

The upgrades provided improved operational flexibility and redundancy in the lime softening process.

## Water Treatment Plant Washwater Recovery Upgrades

Boca Raton, Florida



### Background

The Glades Road Water Treatment Plant utilizes a combination of conventional lime softening (30 million gallons per day (mgd) capacity) and membrane softening (40 mgd capacity). The lime softening treatment process includes a washwater recovery basin and return pumping system for the treatment (settling) and recycle of the filter backwash water and other recyclable treatment process streams. The existing concrete washwater recovery basin is over 35 years old and is exhibiting typical signs of aging.

To maintain the efficiency and integrity of the existing lime softening treatment process, the City desired to design and construct a new washwater recovery system. The proposed system will consist of a washwater recovery basin, a supernatant decanting system, settled sludge handling, and a washwater return pumping system. This new system will be independent of the existing system and will provide the option for redundancy and reliability, as well as allow the City to make repairs and/or modifications to the existing system and surrounding structures and space without interfering with normal plant operations.

## The Project

The design scope included the following improvements:



*Basin Spray Cannons*

- Construction of an octagonal concrete, open-top washwater recovery basin to receive and treat plant recycle streams (e.g., filter backwash water, filter to waste from the pressure filters, and filter to waste from the gravity filters in the future).
- Construction of a supernatant decanting system, settled sludge handling, and washwater return pumping system. The return pumping system will consist of a cast-in-place concrete wetwell adjacent to the washwater recovery basin and three return pumps. The pumps will be controlled by the liquid level in the wetwell.
- Replacement of fourteen (14) existing valve actuators including surrounding lighting and all related electrical, and instrumentation and control systems.
- Yard piping improvements to connect the new system to the filter washwater waste piping, sludge thickener feed piping, and washwater return piping.
- Associated sitework, geotechnical and foundation construction.
- Electrical improvements to provide power to the washwater return pump station.
- Instrumentation and controls associated with the recovery basin and return pumping system.

MBC scope of services for this project included:

- Preparation of Construction Drawings and Technical Specifications
- Opinion of Probable Construction Cost
- Permitting services

The contract for construction of the project was awarded to Lanzo Construction, Corp. MBC provided contract administration services during construction. The project was completed in November 2024 and is currently in active use.



*Basin Pump Station*



*48-inch pipe tie-in*

# Design Criteria Packages

H 2  
M

## City of Fort Lauderdale

Fort Lauderdale, FL

**Construction Cost:** TBD

SERVICES  
PROVIDED

Architecture  
Structural Engineering  
Mechanical Engineering

Electrical Engineering  
Plumbing and Fire  
Protection Engineering



H2M is responsible for the development of two design criteria packages for the Fire Station 13 and Fire Station 88 projects, which are intended to be completed under design-build contracts.

H2M has been tasked with development of project definition and documentation and design criteria packages for the station projects to be bid to design-build teams. This has involved detailed preliminary investigation of the buildings and sites, preparation of a topographic and boundary survey, geotechnical soil sampling, engineering and architectural and other related tasks, 3D renderings of up to three design concepts, and 30% design plans and specifications. The team also identified permits required by the City, County, FDOT and FDEP; dewatering and stormwater pollution prevention requirements; and impacts to local business and residents, based on the data collection.

In addition, H2M is responsible for bidding and procurement support, attending the pre-bid meeting, responding to inquiries from bidders, and serving as technical advisor to the City during review of design-build proposals. The solicitation was made available for public bidding in the Summer of 2025.

After selection of the design-build team, H2M will review the design documents at 60% and 100% completion to verify compliance with the design criteria. We will respond to requests for clarification, serve as a technical advisor to the City, and provide final review of project closeout documents and support during substantial completion and punchlist phase.



# Surface Water Treatment

## City of West Palm Beach

West Palm Beach, FL

**Construction Cost:** Varies by task

SERVICES  
PROVIDED

Water Resources  
Engineering  
Permitting

Bidding  
Construction  
Administration



H2M is providing water resources engineering to the City of West Palm Beach, FL, on an as-needed basis.

H2M was selected by the City of West Palm Beach, FL, to provide engineering and professional consulting services for surface water treatment projects on an as-needed basis. Work includes pre-design analysis, preliminary design, final design and construction documents, permitting, bidding, and construction administration. Assignments to date include the following:

**Backwash Recovery Basin Pump Station:** The City owns and operates a municipal water treatment plant (WTP), which includes a backwash recovery clarifier. The clarifier is served by an existing doghouse-style duplex pump system that is currently supplemented by a portable diesel-fueled backup pump due to the duplex system being unable to meet demand. H2M is designing the replacement of the existing pump array with new pumps, to be configured as duplex submersibles. The pumping capacity will be increased from the existing nominal 1,000 gpm per-pump rating to 1,500 gpm 40' TDH rated capacity per pump.

**Sludge Drying:** The City's existing doghouse-style duplex pump system is supplemented by a portable diesel-fueled backup pump. The City procured a replacement duplex pump system for the doghouse-style duplex pumping system consisting of new end suction pumps packaged with a vacuum priming system. The City is currently in the process of replacing the existing end suction pumps with duplex submersibles. As such, the new procured packaged end suction pumps and priming system and controls are currently not expected to be utilized. The City tasked H2M with evaluating if the procured package duplex pump system

could be used to assist with its residuals drying ponds. A trailer powered hydraulically driven submersible pump is currently used to move sludge between ponds to facilitate the drying process.

**Spill Prevention, Control & Countermeasures (SPCC) Plan & Chemical Bulk Storage (CBS) Program Review:** H2M is preparing an SPCC Plan and performing a review of the CBS program for the City's WTP. The SPCC will include information on prior spill events; a prediction of direction and flow for potential spill events; a description of existing storage systems and spill prevention equipment; a review of site drainage and facility transfer operations; a review of inspections and records, an assessment of the facilities security systems; and training staff on spill prevention procedures. The CBS program review will inspect all chemical bulk storage areas, including indoor and outdoor storage tanks, drums, and containers. The inspection will involve verifying the conditions of containment areas, spill control measures, secondary containment, and venting; evaluating labeling, signage, and hazard communication compliance; assessing chemical segregation practices to prevent incompatible chemical storage; an exterior visual assessment of the physical condition of storage tanks, piping, valves, and connections for signs of wear, corrosion, or leakage; and a review the facility's tank testing records and any recent maintenance or inspections. A gap analysis will be provided to the City for review and implementation.

# New Emergency Generator

## Town of Davie

Davie, FL

**Construction Cost:** \$1 million

SERVICES  
PROVIDED

Electrical Engineering  
Mechanical Engineering  
Plumbing Engineering

Architecture  
Environmental  
Engineering



H2M is developing designs and preparing bid documents to construct a new emergency generator at the Town of Davie Police Headquarters.

The Town currently has an underground storage tank fuel delivery system and an existing 750 KW emergency interior generator. The existing generator system provides full building back-up power for the Town's Police Headquarters building and adjacent Fire Department building. During Hurricane Irma, the generator and emergency system failed and critical operation facility buildings were left without back-up power. The generator has been intermittently failing since the hurricane. The Town received FEMA Hazard Mitigation Grant Program (HMGP) funding for a replacement.

H2M is designing a new 750 KW exterior emergency generator that will tie back to the buildings' emergency electrical systems. The generator will also be tied back to the existing fuel storage tank. H2M reviewed the FEMA flood maps to elevate the generator as required above the Design Flood Elevation.

H2M is also responsible for permitting and approvals, bidding assistance, and construction administration services.



# Advanced Wastewater Treatment Facility Wastewater Reuse for Golf Course Irrigation

H 2  
M

## Town of Riverhead

Riverhead, NY

**Construction Cost:** \$21.9 million

SERVICES  
PROVIDED

Design  
Construction  
Administration

Operation and  
Maintenance Manual  
Construction Operation

The Riverhead Sewer District was required to upgrade the existing sewage treatment plant in order to achieve a total nitrogen effluent limitation of 3.2 mg/l based on the total maximum daily load (TMDL) conducted for the Peconic Estuary Program. Due to the location of the Suffolk County Indian Island Golf Course, adjacent to the wastewater treatment plant, wastewater effluent will be used seasonally as an alternative water supply source for irrigation of up to 450,000 gallons per day. This is the first wastewater reuse project in New York.



AWARDS

◆ ACEC New York  
Diamond Award

Benefits from this project extend well beyond nitrogen loading within the Peconic Estuary. Water shortages may change the water supply conditions that are currently taken for granted. The golf course currently utilizes on-site wells for irrigation. Continued use of groundwater as the irrigation source of supply is bound to affect the salt water / fresh water boundary. Irrigation with potable water from the local municipal system is already expensive and puts a stress on the existing potable water supply.

We designed the treatment plant upgrade and water reuse systems. The design included the installation of all process equipment including, but not limited to: headworks fine screen, screenings, washings, add air diffusers to the existing Sequencing Batch Reactor (SBR) tank, convert the existing post-equalization tank to Membrane Biological Reactor (MBR) system, aeration blowers, pumps, chemical feed equipment, polymer mixing and feed equipment, controls, piping, backflow preventers, convert the existing trickling filter tanks to treated effluent tanks, a booster pump for the treatment plant effluent re-use system, a booster pump to supply treatment plant effluent for irrigation use at the adjoining golf course, UV disinfection equipment for WWTP discharge, and a closed vessel UV disinfection system for the golf course re-use systems. The electrical design included a primary electrical service, main secondary feeders, power distribution, and instrumentation control wiring, standby generator for new equipment, and motor control centers. We also prepared the structural, architectural, mechanical, plumbing and HVAC designs.



Since permit levels of treatment must be maintained during construction, certain existing process equipment and units cannot be taken offline until new facilities are placed into permanent, fault free operation. Consequently, we included the specifications a construction sequence. During construction we provided construction administration, inspection, and start-up services. We also prepared an operation and maintenance manual for the upgraded advanced wastewater treatment system and the water reuse systems.



## City of Pompano Beach Utilities Treatment Plant Reclaimed WTP Piping Modifications & Production Improvements

Hillers Electrical Engineering provided electrical and instrumentation and control design for the Reclaimed WTP project. This project consisted of adding 13 new motor operated valves, replacement of three existing low pressure distribution pumps and Variable Frequency Drives (VFDs), adding of two new low pressure distribution pumps, two filter feed pumps and VFDs and a new remote Programmable Logic Controller panel. This project is under bidding process. The construction inspection services will be provided at the time of construction phase.

### Project Highlights:

- Design of a new electrical panel and provide power to 13 new motor operated valves
- Design of a new remote Programmable Logic Controller panel to provide control to 13 new motor operated valves
- Design replacement 480V feeder of existing low pressure distribution pumps
- Design replacement of three existing low pressure distribution pumps and VFDs
- Design of two new low pressure distribution pumps and VFDs
- Design of two new filter feed pumps and VFDs



City of Pompano Beach  
1205 NE 5<sup>th</sup> Avenue  
Pompano Beach, FL 33060  
Phil Hyer  
Phil.Hyer@copbfl.com  
(954) 545-7016  
Completed 2020



## City of Boca Raton WTP Rehabilitation of the Membrane Pretreatment Pressure Filters Project

Hillers Electrical Engineering, Inc. provided the electrical, instrumentation & controls (I&C) design and construction services for the Rehabilitation of The Membrane Pretreatment Pressure Filters Project.

### Project Highlights:

- Designed new NEMA 4X 316 stainless steel outdoor rated power panel (480V power panels) for replacement motorized valve actuators.
- Designed replacement of all exposed conduits and new wires associated with power and control wiring at the pressure filter system.
- Designed new raw water instrument panel and associated pressure transmitters, loss of head differential pressure transmitter, and turbidity analyzer.
- Designed new feed water instrument panel and associated pressure transmitters, ORP analyzer, pH and temperature analyzer, conductivity, and turbidity analyzer.
- Instrumentation and controls system design also included modification of the existing PLC panel.



City of Boca Raton  
201 W. Palmetto Park Road  
Boca Raton, FL 33432  
Brandon Tufts  
[btufts@bocaraton-fl.gov](mailto:btufts@bocaraton-fl.gov)  
561.338.7374  
Design completed: June 2017  
Construction completed: August 2019



## PEMBROKE PINES WATER TREATMENT PLANT ELECTRICAL IMPROVEMENTS AND HURRICANE HARDENING

Hillers Electrical Engineering, Inc. provided the Electrical and Instrumentation & Control Design and Construction Services for the City of Pembroke Pines Water Treatment Plant (WTP) Electrical improvements and Hurricane Hardening project.

### Project Highlights:

- Replacement of aging main switchboards, automatic transfer switches (ATS's), main breaker and generator parallel switchboard with new main breaker, ATS's, and switchboards
- Design the replacement of electrical equipment while keeping the plant in operation
- Design new Manual Transfer Switches with portable generator quick connection boxes in case of emergency generator failure
- Design replacement of outdoor motor control center with redundant power feeds to improve reliability and redundancy
- Design new LED lighting, new HVAC system, new convenient power outlets, new overhead wireways, etc. for the main electrical room



City of Pembroke Pines  
8300 South Palm Drive  
Pembroke Pines, FL 33025  
George Wrvs, P.E.

[gwrves@ppines.com](mailto:gwrves@ppines.com)

(954) 435-7979

Design duration: February 2022 – July 2023

Construction duration: February 2024 – Ongoing (late 2026)





# SOUTHERN REGIONAL WASTEWATER TREATMENT

Hollywood, FL

## OWNER

City of Hollywood, FL

## CLIENT

Nutting Environmental of  
Florida, Inc.

## PROJECT DURATION

2020 - 2020

## REFERENCE

Scott Ersland  
Nutting Environmental of  
Florida, Inc.  
561-732-7200  
scotte@nefmail.com

## KEITH PRACTICE LINE

Facility

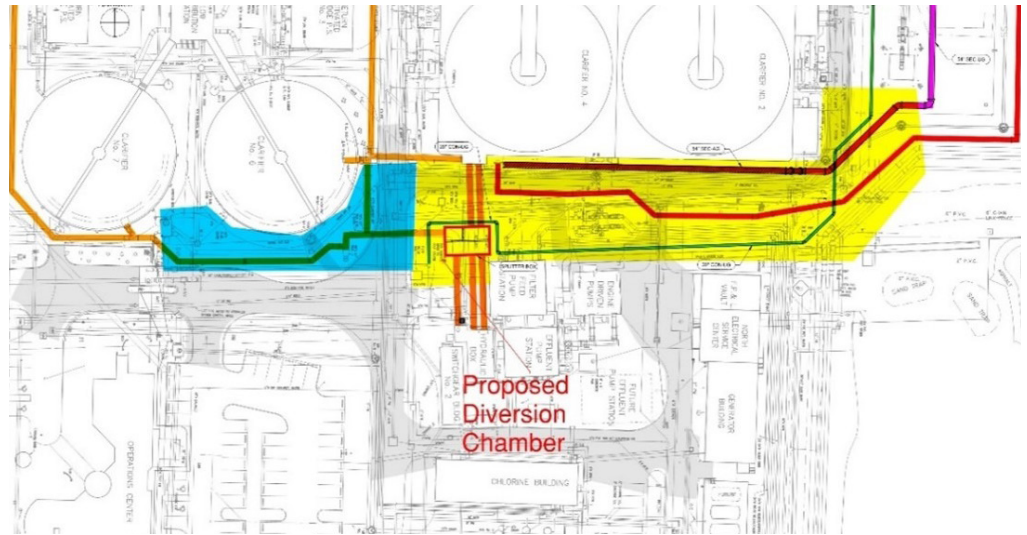

KEITH was tasked to provide subsurface utility engineering services for up to 5 days of horizontal utility designation within the project limits of the City of Hollywood Water Treatment Facility. Additionally, a 10' radius of 5 soil borings were included in the investigation. Findings were painted and flagged in the field.



## BROWARD RECLAIMED WATER PLANT EXPANSION

Fort Lauderdale, FL

### OWNER

Broward County Commission

### CLIENT

Brown and Caldwell

### PROJECT DURATION

2015 - 2024

### REFERENCE

Celia Earle  
Brown and Caldwell  
954-299-6713  
cearle@brwncald.com

### KEITH PRACTICE LINE

Facility

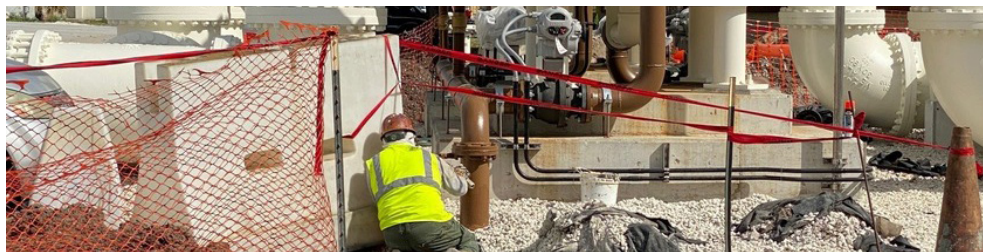

KEITH, as subconsultant, assisted the Client in developing a KEITH Facility project that included the expansion of the North Regional Wastewater Treatment Plant (NRWWTP) to bring it in line with updated State Ocean Outfall Rules and increases in Baseline Flow percentages. KEITH provided services to the Client including survey/SUE and landscape architecture. The KEITH Team assisted the Client in utilizing SUE techniques within the plant and for proposed yard piping routing, Ground Penetrating Radar (GPR) to designate, verify, and document location of underground facilities, major piping, conduits, and stormwater facilities, supplemental topographic survey verifying the elevation of hydraulic process structures, landscape architecture concepts associated with the exterior design and construction of two buildings, tree inventory and analysis, landscape, irrigation, and tree disposition plans, and detailed engineering services for the yard piping. The NRWWTP utilized a 54-inch ocean outfall and Class I Injection Wells as the primary means of treated effluent disposal. Legislation by the State of Florida, generally known as the "Ocean Outfall Rule", eliminated the use of ocean outfalls for disposal after 2025. The Outfall Rule also mandates the implementation of a wastewater reclamation program with a minimum capacity of 60 percent of the facility's Baseline Flow above and beyond current reclaimed water application. This mandate equals a required total reclaimed water production of approximately 26 mgd. With the implementation of these upgrades and improvements the NRWWTP now has a firm-rated capacity within the state law requirements.

## Terminal 3 Expansion @ Fort Lauderdale/Hollywood International Airport Ft. Lauderdale, FL

Quest Engineering Services & Testing, Inc. (QuEST) provided geotechnical services to the Broward County Aviation Department for the subject terminal expansion and improvements to the Baggage Handling System. The work was done as part of a Design-Build Team led by Whiting Turner Contracting Company. This project involved the construction of a new in-line baggage screening facility at Terminal 3 of the Ft. Lauderdale-Hollywood International Airport (FLL). Various structural bump-outs were designed to support the various terminal improvements. The facility was constructed in such a way as to allow existing baggage screening positions to remain active during the construction period. The construction employed pre-cast concrete elevated floor framing and steel joist roof framing, supported by concrete columns, beams and steel columns. Besides providing subsurface study and geotechnical engineering services, we also monitored the augercast pile installation. In addition, we provided construction materials testing and special inspection services.

### Project Highlights:

- SPT Borings
- Augercast Pile Load Tests
- Augercast Pile Installation Monitoring
- Construction Materials Testing
- Structural (Special) Inspections
- Baggage Handling Systems – Welding & Bolting Inspections

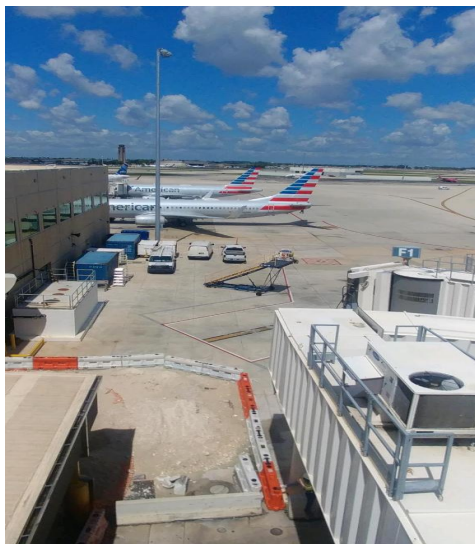

The Whiting Turner Contracting Company  
1901 W. Cypress Creek Road, Suite 101  
Ft. Lauderdale, FL - 33309

Mr. Michael Avni  
(954) 776 0800

Our Scope Completed in 2023

**Planned Tunnel under Las Olas Boulevard  
Ft. Lauderdale, FL**

Quest Engineering Services & Testing, Inc. (QuEST) provided geotechnical services to the City of Ft. Lauderdale for the planned tunnel. The work was done as a sub-consultant to Hazen & Sawyer. The subject project envisages the construction of a two-way tunnel under Las Olas Boulevard to connect downtown Ft. Lauderdale and Ft. Lauderdale Beach. The tunnel was to be constructed by The Boring Company. Our scope was a series of deep borings along the planned tunnel alignment. We also did an exhaustive series of laboratory soil tests. This project is still in the feasibility study phase and has not yet progressed to the detailed design stage.

**Project Highlights:**

- Seven SPT Borings to depths of 100 feet below grade
- Direct Shear Tests
- Abrasivity Tests
- Permeability Tests
- Expansion Index Swell Tests
- Percent Quartz Tests
- Sulfate & Chloride Tests



Hazen & Sawyer  
4000 Hollywood Boulevard, Suite 750 N  
Hollywood, FL – 33021

Ms. Patricia A. Carney, P.E.  
(954) 987 0066

Our Scope Completed in 2022

## 7. Resumes of Key Personnel

---

Staffing continuity will be essential to the success of the projects under this contract. MBC's proposed staff for this contract have a long working history with the City of Pompano Beach, are familiar with the City's facilities, and have proven working relationships with City staff.



**Frank Brinson, P.E., CDT**  
Principal-In-Charge and Vice President



#### Experience Highlights

Mr. Brinson has more than 30 years of experience in a wide range of water and wastewater utility projects.

Specialties include water and wastewater treatment facilities, membrane treatment, pumping and hydraulic systems, and utility infrastructure.

#### Education

B.S. – Environmental Engineering,  
University of Florida, 1991

#### Professional Registration

State of Florida  
Professional Engineer  
License No. 51313

#### Professional Certifications

CDT - Construction Document  
Technologist, Construction  
Specifications Institute

#### Publications

"Ending Pretreatment Chemical  
Dependency at a 10 MGD  
Nanofiltration Plant" (Co-Author)  
AWWA/AMTA MTC, Knoxville,  
Tennessee, February 2023.

"Optimizing Chemical  
Pretreatment and Membrane  
Element Performance at a 10 MGD  
Nanofiltration Plant" (Co-Author)  
AWWA/AMT MTC, West Palm  
Beach, Florida, July 2021.

## Professional Experience

Mr. Brinson is an environmental engineer with over thirty years of experience. He is experienced in both management and technical execution of projects with expertise in engineering analysis, modeling, utility master planning, design, permitting, preparation of bidding and construction documents, construction contract administration, and construction management. Specialties include water and wastewater treatment facilities, nanofiltration (NF) and reverse osmosis (RO) membrane treatment systems, pilot testing, treatment process optimization, pumping and hydraulic systems, and utility infrastructure. The following are some representative projects in which Mr. Brinson has been involved.

## Project Experience

**Principal Engineer/Engineer of Record, Water Treatment Plant Emerging Contaminants Design Upgrades, City of Pompano Beach, Florida.** The City has received an SRF planning and design loan under the emerging contaminants funds under Bipartisan Infrastructure Law. MBC assisted the City with preparation and submittal of the planning document in 2024. MBC is currently designing the improvements listed in the planning document. The project consists of the expansion of the City's existing 10 million gallon per day capacity nanofiltration (NF) process to 30 mgd to meet the City's projected buildout maximum day demands, and installation of the second concentrate disposal deep injection well. Mr. Brinson serves as the principal engineer and as the co-engineer of record for this project. The design phase of the project is anticipated to be completed in March 2026.

**Project Manager/Engineer of Record, Membrane Element Replacement, City of Pompano Beach, Florida.** This project included the replacement of the 1,820 nanofiltration (NF) membrane elements in the 10 mgd capacity NF process at the City's water treatment plant. The project included pilot testing of membrane element selections from membrane element manufactures for prequalification for bidding and to optimize the chemical pretreatment protocol and element selection. Mr. Brinson was responsible for design and permitting of a 2:1 array pilot test unit utilizing 8-inch diameter, seven-element (full size) membrane pressure vessels, engineering assistance during bidding, membrane loading and proof testing. Pilot testing was successful in optimizing the NF process by completely eliminating chemical pretreatment and reducing the required NF process feed pressure, resulting in an annual operating cost savings of approximately \$600,000. This project reached final completion in May 2020. The facility has operated with no chemical pretreatment since final completion, and as of March 2025 has required only four cleanings of the membrane elements.

**Project Manager/Engineer of Record, Glades Road Water Treatment Plant, 40 mgd Nanofiltration (NF) Membrane Element Replacement, City of Boca Raton, Florida.** After commissioning of the new Membrane Softening Process Addition to the Glades Road Water Treatment Plant, the City operated the process successfully (with no chemical pretreatment) for approximately nine years. In 2014, the City elected to proceed with a scheduled replacement of the membrane elements for the NF process, and contracted

**Frank Brinson, P.E., CDT**

with MBC. The project included pilot testing, development of technical specifications and bidding documents for the replacement membrane elements as well as the membrane loading contract, permitting, engineering services during membrane loading, and engineering supervision of membrane performance testing. Mr. Brinson served as project manager during both the design and replacement phases of the project.

**Principal Engineer/Engineer of Record, Glades Road Water Treatment Plant Expansion and Rehabilitation of the Membrane Pretreatment Pressure Filters, City of Boca Raton, Florida.** The expansion and rehabilitation projects included the addition of two new 10-foot diameter by 41-foot long, two-cell steel pressure filters, similar in design to the existing pressure filters, with all required face piping, fittings, valves, electric valve operators, electrical systems, instrumentation, and controls. The rehabilitation efforts involved the replacement of valve actuators, backwash air inlet check valves, air release valves, and filter media in six filter cells, installation of a drain loop and drain valve in the existing main steel air feed piping, and other renewal and replacement activities, as well as electrical and instrumentation and control improvements. Additionally, three gravity filters were rehabilitated, including media replacement and inspection. Mr. Brinson oversaw the design and permitting and served as principal engineer.

**Principal Engineer/Engineer of Record, Four-Log Virus Treatment Upgrades Study, Design, and Construction, City of Boca Raton, Florida.** This project included the investigation and evaluation of alternatives for optimizing four-log virus treatment relative to disinfection by-product formation, as well as final design and construction of the necessary improvements associated with the selected alternative. The selected alternative included the addition of channel mixers and intra-basin baffles within the lime softening process clearwells, relocation of the sodium hypochlorite and ammonia injection points, and the relocation of the free chlorine, temperature, and pH sample points for four-log virus treatment compliance monitoring. In addition to the disinfection-related upgrades, the design included the addition of filter-to-waste piping and control valves to route the filter effluent to the washwater recovery basin, as well as yard piping modifications to improve operational flexibility and reliability. Mr. Brinson served as the engineer of record and principal engineer during design and is currently providing engineering services during construction. Construction is anticipated to be completed in the fourth quarter of 2026.

**Lead Membrane Process Design Engineer, Delray Beach Membrane Water Treatment Plant, City of Delray Beach, Florida (September 2025).** This project involved design of the addition of a 25-mgd NF process to the City of Delray Beach's conventional lime softening process to comply with the National Primary Drinking Water Regulation (NPDWR) for per- and poly-fluoroalkyl substances (PFAS) under a progressive design-build (PDB) project delivery. MBC was a subconsultant to the prime project professional (CDM Smith, Inc.) (with Mr. Brinson serving as the lead designer and project manager) and was tasked with leading the membrane treatment process design, including a 5-micron cartridge filter system, membrane feed pumps, seven 3.67 mgd NF units, and membrane cleaning and permeate flush systems. During the preliminary design phase, MBC was also responsible for individual technical memoranda addressing the potential for blending of the NF permeate with the lime softened water to meet the PFAS NPDWR, evaluation of the raw water supply system relative to NF treatability, raw water quality characterization, as well as NF membrane pilot testing. The findings of the technical memoranda were incorporated into the final design of the facility. Final design was completed in September 2025. Construction is scheduled to begin in early 2027, and is expected to be completed in November 2027. The estimated construction cost is approximately \$250 million.

**Principal Engineer/Engineer of Record, City of Pompano Beach Water Treatment Plant Emerging Contaminants Upgrades Facilities Plan, Pompano Beach, Florida.** In March 2023, the USEPA proposed a National Primary Drinking Water Regulation (NPDWR) for certain per- and polyfluoroalkyl substances (PFAS). Under the 2021 Bipartisan Infrastructure Law (BIL), Federal grant funds were made available to drinking water utilities for implementation of water treatment plant upgrades that are necessary to provide compliance with the proposed PFAS regulations. MBC assisted the City in securing a grant in the amount of \$9,595,000 for PFAS-related upgrades to the City's water treatment plant. This grant/loan program is administered by the State of Florida Drinking Water State Revolving Fund (DWSRF) program. Mr. Brinson served as co-author and engineer

**Frank Brinson, P.E., CDT**

of record for the DWSRF Facilities Plan in conformance with applicable DWSRF funding requirements. The Facilities Plan included a treatment technology upgrades alternative analysis considering nanofiltration (NF) and reverse osmosis (RO) membrane treatment, granular activated carbon (GAC), and anion exchange (AIX) for removal of PFAS, as well as development of conceptual designs and capital and operation and maintenance (O&M) cost estimates for each technology alternative. The study included on-site pilot testing of the GAC and AIX technologies. (Pilot testing of membranes was not necessary because the City's full-scale NF facility provided sufficient operating data necessary for the analysis.)

**Principal Engineer/Engineer of Record, Transfer Pumping Upgrades at the Water Treatment Plant, City of Boca Raton, Florida.** The City's 30 mgd lime softening process operates in parallel with the 40 mgd nanofiltration process. The water from these processes is blended and pumped to on-site finished water storage tanks using two transfer pumping systems, consisting of six pumps total. This project includes replacement of three 150 hp transfer pumps, addition of a seventh transfer pump, process piping modifications, and a comprehensive renovation to the buildings associated with the transfer pump systems. Design of this project was completed in July 2025, and the project is expected to be advertised for bid by the first quarter of 2026. Mr. Brinson oversaw the design and permitting and served as principal engineer and engineer of record.

**Principal Engineer/Engineer of Record, Glades Road Water Treatment Plant, Washwater Recovery Upgrades, City of Boca Raton, Florida.** The Glades Road Water Treatment Plant lime softening process utilizes a washwater recovery basin and return pump system for the treatment (settling) and recycle of filter backwash water and other recyclable treatment process streams. The existing washwater recovery basin was over 35 years old and under this project MBC was authorized to design a new 575,000-gallon octagonal concrete washwater recovery basin with improved process capabilities (supernatant decanting system and a dedicated pump station for a settled sludge handling and washwater return pump system). Mr. Brinson served as the engineer of record and principal engineer during design and provided engineering services during construction.

**Principal Engineer, Continuing Nanofiltration Process Optimization Services, City of Boca Raton, Florida.** Since January 2008 MBC has provided continuing process technical services that include quarterly review of the membrane process performance data, plant operating records, wellfield operating records, operating practices, and preparation of quarterly reports on the findings of MBC's review, including recommendations for improvements in operating practices and data collection for optimization of the treatment process and improvements in plant efficiency and reliability. Mr. Brinson served as project manager and engineer of record during design and construction of the plant and currently serves as principal engineer of this project.

**Project Manager/Engineer of Record, Glades Road Water Treatment Plant, 40 mgd Membrane Softening Process Addition, City of Boca Raton, Florida.** This project included design and construction administration for a 40 mgd nanofiltration membrane softening process addition to the City's 70 mgd conventional lime softening plant. Also included were raw water source evaluation and rehabilitation, evaluating pre- and post-treatment technologies, and membrane pilot testing. Mr. Brinson was engineer of record and was involved in engineering planning, preliminary and final design, permitting, financing, bidding, construction administration, electronic operation and maintenance manual preparation, operator training, and start-up of the facility. Bids for the project were received on May 16, 2001, and the low bid (\$47.2 million) was approximately 10 percent below the original engineer's estimate. The plant was brought on line in August of 2004. On the date of commissioning, this facility was the largest membrane softening facility in operation in the world and is currently one of only two large NF facilities in Florida that operate with no chemical pretreatment. The project won the 2006 Florida Institute of Consulting Engineers (FICE) Grand Award for Engineering Excellence in Water and Wastewater.

**Principal Engineer, Nanofiltration Process Expansion Study, City of Pompano Beach, Florida.** The City owns and operates a 10-mgd NF membrane treatment plant. The NF plant was originally designed to accommodate future expansion to a capacity of 20 mgd through the addition of five additional NF units and associated equipment within the existing building. Mr. Brinson was responsible for evaluation of the existing

**Frank Brinson, P.E., CDT**

process systems and plant infrastructure to develop a detailed plan for the cost-effective expansion of the plant to the maximum capacity that can be supported by the existing major infrastructure (e.g., within the existing building) in a phased manner. The expansion program identified in the study includes buildout of the existing NF facility to 20 mgd, as well as an additional stand-alone 10-mgd expansion, for an ultimate NF process capacity of 30 mgd.

**Project Manager, Membrane Softening Process Renovation Needs Study, City of Boca Raton, Florida.**

This project included evaluation of the City's 40-mgd capacity membrane softening facility that was placed online in 2004. Since the original commissioning of the plant, the process equipment, support systems and associated structures had aged and were in need of normal repair, renewal, and replacement. The comprehensive study identified necessary improvements and upgrades to extend the service life of the plant and improve operational flexibility, process efficiency, and overall reliability. The study grouped the proposed upgrades into individual projects for implementation (final design and construction). Mr. Brinson served as project manager for the preparation of the study and report, including preliminary opinions of construction cost, a construction sequencing plan, and implementation schedule.

**Principal Engineer, PFAS Water Treatment Impact Assessment, Broward County Water and Wastewater Services, Florida.**

As a subconsultant to the Prime, MBC conducted a conceptual assessment of available options to mitigate observed PFAS levels at the District 1A and 2A Water Treatment Plants. The assessment included: review and evaluation of granular activated carbon, ion exchange, and membrane treatment technologies, development of conceptual site layouts, and demonstration of implementation considerations for the selected treatment technology. Mr. Brinson performed and presented the evaluation of treatment technologies and developed conceptual site layouts.

**Project Manager/Engineer of Record, Nanofiltration Unit and Degasifier Upgrades, City of Boca Raton, Florida.**

Based on the findings outlined in the Membrane Softening Process Renovation Needs Study, the City has undertaken a Water Treatment Plant Upgrades program to complete a comprehensive renovation of all major components of the Glades Road Water Treatment Plant, membrane softening process equipment, pumping and storage facilities, power supply and distribution and control systems, and plant infrastructure over a ten-year period. This project was identified in the Needs Study, and Mr. Brinson was responsible for the design and preparation of construction contract documents to rehabilitate and implement recommended upgrades to the NF units, degasifiers, and odor control systems. The construction phase of this project is currently underway, and it is anticipated to be completed in September 2026.

**Project Manager, Lime Softening Chemical Building Renovation Needs Study, City of Boca Raton, Florida.**

The lime softening treatment process includes a chemical building (Building 11) that houses the lime storage silos, lime slakers, and other equipment, supporting systems, and functions. This comprehensive study on Building 11 identified and cataloged the treatment process/mechanical functions provided by the building, investigated and documented the existing electrical service and power distribution systems associated with the building, and evaluated the structural integrity of the building and associated structures and equipment, specifically the lime silos. Mr. Brinson served as project manager for the preparation of the study and report, including preliminary opinions of construction cost, a construction sequencing plan, and implementation schedule.

**Project Manager/Engineer of Record, Seminole Tribe of Florida Hollywood Raw Water Supply Improvements, Hollywood, Florida.**

This project included installation of well pumps and approximately 1,050 linear feet of raw water main (8" to 16" diameter) from the new pumps to the existing water main at the Hollywood Reservation Water Treatment Plant. Each well head is per STOF's standard design including valve train with flow metering and adjacent control and power panels. Standby power is provided to the well pumps from existing generators at the treatment plant. A new acid injection point was installed to serve the new wells. Mr. Brinson was responsible for design and construction phase engineering services.

**Frank Brinson, P.E., CDT**

**Project Manager/Engineer of Record, 3.0 mgd Reverse Osmosis Water Treatment Plant, Raw Water Wellfield, and Concentrate Disposal Injection Well, City of Clewiston, Florida.** This project consisted of designing a new Floridian aquifer raw water supply wellfield, a 3.0 mgd low-pressure reverse osmosis water treatment plant, and concentrate disposal deep injection well. Mr. Brinson was engineer of record and was involved in preliminary and final design, pilot testing, permitting, construction administration, and start-up. The project maintained a very aggressive design and construction timeline to meet the City's obligation to the previous water supplier. Construction of the plant was initiated in April 2006, and the plant was brought online in December 2007. Change orders at Substantial Completion were less than 1 percent of the original bid price.

**Principal Engineer, Blue Hills Seawater Reverse Osmosis Water Treatment Plant (SWRO WTP), Water and Sewerage Corporation of the Bahamas.** This project included preliminary design and preparation of Tender Documents for a 20-year Build-Own-Operate (BOO) contract for a 6 million imperial gallons per day (mgd) (7.2 US mgd) seawater reverse osmosis water treatment plant. The constructed facilities included seven raw water supply wells, chemical pretreatment and cartridge filtration, a 5 mgd SWRO process (expandable to 6 mgd), degasification, chemical post-treatment, finished water storage, and four concentrate disposal wells. Engineering services included preliminary design, preparation of Tender Documents, bidding services, review and evaluation of tenders, assistance with execution of contracts, shop drawing review, construction observation, and miscellaneous construction administration services. Mr. Brinson served as the project manager of design for this project.

**Principal Engineer, Hood Road Water Treatment Plant Membrane Conversion, Seacoast Utility Authority (SUA).** This project included design of a 26.0 mgd nanofiltration membrane process and a 3.5 mgd low pressure reverse osmosis membrane process at SUA's existing Hood Road Water Treatment Plant. Mr. Brinson was responsible for design of the sulfuric acid, antiscalant, sodium hydroxide, sodium hypochlorite, and corrosion inhibitor chemical storage and feed systems for pretreatment of the membrane feedwater and post-treatment of the finished water, start-up of the treatment process, and preparation of the plant's Operation and Maintenance Manual.

**Principal Engineer, Water Treatment Plant Reverse Osmosis (RO) Membrane Replacement, City of Lake Worth, Florida (Preliminary Design).** The City of Lake Worth owns and operates a 4.5 mgd capacity brackish RO membrane treatment process which operates in parallel with a conventional lime softening process. Since the RO membranes have been in operation since 2011, the City wished to evaluate options for replacing the membranes. Mr. Brinson was responsible for analysis of raw and finished water quality, identification of finished water quality goals, preliminary selections of potential membrane element replacements, and preparation of draft technical specifications for the replacement project.

**Principal Engineer, BCWWS North Regional Reclaimed Water Treatment Plant Expansion, Broward County, Florida.** This project includes design and construction of a 16.0 mgd expansion to the reclaimed water productions systems (i.e., filter feed pumps, filters, chlorine contact basins, reclaimed water distribution pumps, chemical feed systems, and associated structural, electrical, instrumentation, and controls) for BCWWS's NRWWT. Mr. Brinson was involved in design development and construction sequencing specification, and project coordination.

## **Professional Society Memberships**

American Membrane Technology Association (AMTA)  
American Water Works Association (AWWA)  
Construction Specifications Institute (CSI)  
Southeast Desalting Association (SEDA)



**Andrew Barba, P.E., CDT**  
Project Manager and Senior Engineer



#### Experience Highlights

Designing water treatment plant components, pilot testing, and providing construction contract administration.

#### Education

B.S. – Environmental Engineering,  
University of Florida, 2016

#### Professional Registration

State of Florida  
Professional Engineer  
License No. 90713

#### Commonwealth of Massachusetts

Professional Civil Engineer  
License No. 56846

#### Professional Certifications

Construction Document  
Technologist (CDT)

#### Publications

Mr. Barba has authored technical publications and presentations on potable water treatment technologies with a focus on membrane treatment pilot testing and process optimization.

## Professional Experience

Mr. Barba serves as the design leader and senior engineer whose responsibilities include project management, process mechanical design for water and wastewater treatment facilities, permitting, preparation of engineering documents, drawings, and technical specifications, and construction contract administration services. He has been involved in pilot testing, process optimization, potable water, reclaimed water, wastewater treatment plant improvements, stormwater, and collection/distribution system related projects.

## Project Experience

**Project Manager/Engineer of Record, Water Treatment Plant Emerging Contaminants Design Upgrades, City of Pompano Beach, Florida.** The City has received an SRF planning and design loan under the emerging contaminants funds under Bipartisan Infrastructure Law. MBC assisted the City with preparation and submittal of the planning document in 2024. MBC is currently designing the improvements listed in the planning document. The project consists of the expansion of the City's existing 10 million gallon per day capacity nanofiltration (NF) process to 30 mgd to meet the City's projected buildout maximum day demands, and installation of the second concentrate disposal deep injection well. Mr. Barba serves as the project manager and as the co-engineer of record for this project. The design phase of the project is anticipated to be completed in March 2026.

**Project Engineer, Membrane Element Replacement, City of Pompano Beach, Florida.** This project included the replacement of the 1,820 nanofiltration (NF) membrane elements in the 10 mgd capacity NF process at the City's water treatment plant. The project included pilot testing of membrane element selections from membrane element manufactures for prequalification for bidding and to optimize the chemical pretreatment protocol and element selection. During the membrane element replacement phase, Mr. Barba provided construction contract administration, coordination of membrane element loading, start-up, and review of performance testing results. Pilot testing was successful in optimizing the NF process by completely eliminating chemical pretreatment and reducing the required NF process feed pressure, resulting in an annual operating cost savings of approximately \$600,000. This project reached final completion in May 2020. The facility has operated with no chemical pretreatment since final completion, and as of March 2025 has required only four cleanings of the membrane elements.

**Project Engineer/Staff Engineer, Glades Road Water Treatment Plant Expansion and Rehabilitation of the Membrane Pretreatment Pressure Filters, City of Boca Raton, Florida.** The expansion and rehabilitation projects included the addition of two new 10-foot diameter by 41-foot long, two-cell steel pressure filters, similar in design to the existing pressure filters, with all required face piping, fittings, valves, electric valve operators, electrical systems, instrumentation, and controls. The rehabilitation efforts involved the replacement of valve actuators, backwash air inlet check valves, air release valves, and filter media in six filter cells, installation of a drain loop and drain valve in the existing main steel air feed piping, and other renewal and

replacement activities, as well as electrical and instrumentation and control improvements. Additionally, three gravity filters were rehabilitated, including media replacement and inspection. Mr. Barba assisted with preparation of construction documents during design and provided services during construction including; resident project representation, start-up testing and analysis, review of contractor's submittals, requests for information, pay applications, permitting and bidding services, and participating in design meetings with equipment manufacturers and City staff.

**Senior Engineer, Four-Log Virus Treatment Upgrades Study, Design, and Construction, City of Boca Raton, Florida.** This project included the investigation and evaluation of alternatives for optimizing four-log virus treatment relative to disinfection by-product formation, as well as final design and construction of the necessary improvements associated with the selected alternative. The selected alternative included the addition of channel mixers and intra-basin baffles within the lime softening process clearwells, relocation of the sodium hypochlorite and ammonia injection points, and the relocation of the free chlorine, temperature, and pH sample points for four-log virus treatment compliance monitoring. In addition to the disinfection-related upgrades, the design included the addition of filter-to-waste piping and control valves to route the filter effluent to the washwater recovery basin, as well as yard piping modifications to improve operational flexibility and reliability. Mr. Barba served as a senior engineer during design and is currently providing engineering services during construction. Construction is anticipated to be completed in the fourth quarter of 2025.

**Senior Engineer, Delray Beach Membrane Water Treatment Plant, City of Delray Beach, Florida (September 2025).** This project involved design of the addition of a 25-mgd NF process to the City of Delray Beach's conventional lime softening process to comply with the National Primary Drinking Water Regulation (NPDWR) for per- and poly-fluoroalkyl substances (PFAS) under a progressive design-build (PDB) project delivery. MBC was a subconsultant to the prime project professional (CDM Smith, Inc.) (with Mr. Barba assisting with development of TM's, plans, and construction contract documents) and was tasked with leading the membrane treatment process design, including a 5-micron cartridge filter system, membrane feed pumps, seven 3.67 mgd NF units, and membrane cleaning and permeate flush systems. During the preliminary design phase, MBC was also responsible for individual technical memoranda addressing the potential for blending of the NF permeate with the lime softened water to meet the PFAS NPDWR, evaluation of the raw water supply system relative to NF treatability, raw water quality characterization, as well as NF membrane pilot testing. The findings of the technical memoranda were incorporated into the final design of the facility. Final design was completed in September 2025. Construction is scheduled to begin in early 2027, and is expected to be completed in November 2027. The estimated construction cost is approximately \$250 million.

**Project Manager/Senior Engineer, Transfer Pumping Upgrades at the Water Treatment Plant, City of Boca Raton, Florida.** The City's 30 mgd lime softening process operates in parallel with the 40 mgd nanofiltration process. The water from these processes is blended and pumped to on-site finished water storage tanks using two transfer pumping systems, consisting of six pumps total. This project includes replacement of three 150 hp transfer pumps, addition of a seventh transfer pump, process piping modifications, and a comprehensive renovation to the buildings associated with the transfer pump systems. Design of this project was completed in July 2025, and the project is expected to be advertised for bid by the first quarter of 2026. During the design phase, Mr. Barba designed process components, selected design basis equipment, and developed construction contract documents.

**Senior Engineer, Glades Road Water Treatment Plant, Washwater Recovery Upgrades, City of Boca Raton, Florida.** The Glades Road Water Treatment Plant lime softening process utilizes a washwater recovery basin and return pump system for the treatment (settle) and recycle of filter backwash water and other recyclable treatment process streams. The existing washwater recovery basin was over 35 years old and under this project MBC was authorized to design a new 575,000-gallon octagonal concrete washwater recovery basin with improved process capabilities (supernatant decanting system and a dedicated pump station for a settled sludge handling and washwater return pump system). During the design phase, Mr. Barba designed process components, selected design basis equipment, and developed construction contract documents. During the construction phase, Mr. Barba

provided technical construction contract administration services which included, but was not limited to, review of shop drawing submittals, request for information, and development of request for proposal documents.

**Senior Engineer, Continuing Nanofiltration Process Optimization Services, City of Boca Raton, Florida.**

Since January 2008 MBC has provided continuing process technical services to optimize operation of the City's 40-mgd NF process. MBC's services include quarterly review of the membrane process performance data, plant operating records, wellfield operating records, and operating practices, and preparation of quarterly reports on the findings. These reports include recommendations for improvements in operating practices and data collection for optimization of the treatment process and improvements in plant efficiency and reliability. Mr. Barba has had primary responsibility for preparation of quarterly water treatment plant performance reports since 2018.

**Project Engineer, Nanofiltration Process Expansion Study, City of Pompano Beach, Florida.**

The City owns and operates a 10-mgd NF membrane treatment plant. The NF plant was originally designed to accommodate future expansion to a capacity of 20 mgd through the addition of five additional NF units and associated equipment within the existing building. Under this project Mr. Barba assisted with the evaluation of the existing process systems and plant infrastructure to develop a detailed plan for the cost-effective expansion of the plant to the maximum capacity that can be supported by the existing major infrastructure (e.g., within the existing building) in a phased manner. The expansion program identified in the study includes buildout of the existing NF facility to 20 mgd, as well as an additional stand-alone 10-mgd expansion, for an ultimate NF process capacity of 30 mgd.

**Project Engineer, Membrane Softening Process Renovation Needs Study, City of Boca Raton, Florida.**

This project included evaluation of the City's 40-mgd capacity membrane softening facility that was placed online in 2004. Since the original commissioning of the plant, the process equipment, support systems and associated structures have aged and are in need of normal repair, renewal, and replacement. The comprehensive study identified necessary improvements and upgrades to extend the service life of the plant and improve operational flexibility, process efficiency, and overall reliability. The study grouped the proposed upgrades into individual projects for implementation (final design and construction). Mr. Barba assisted with the preparation of the study and report, including preliminary opinions of construction cost, a construction sequencing plan, and implementation schedule.

**Senior Engineer, PFAS Water Treatment Impact Assessment, Broward County Water and Wastewater Services, Florida.**

As a subconsultant to the Prime, MBC conducted a conceptual assessment of available options to mitigate observed PFAS levels at the District 1A and 2A Water Treatment Plants. The assessment included: review and evaluation of granular activated carbon, ion exchange, and membrane treatment technologies, development of conceptual site layouts, and demonstration of implementation considerations for the selected treatment technology. Mr. Barba performed and presented the evaluation of treatment technologies and developed conceptual site layouts.

**Senior Engineer, Nanofiltration Unit and Degasifier Upgrades, City of Boca Raton, Florida.**

Based on the findings outlined in the Membrane Softening Process Renovation Needs Study, the City has undertaken a Water Treatment Plant Upgrades program to complete a comprehensive renovation of all major components of the Glades Road Water Treatment Plant, membrane softening process equipment, pumping and storage facilities, power supply and distribution and control systems, and plant infrastructure over a ten-year period. This project was identified in the Needs Study, and Mr. Barba assisted with the design and preparation of construction contract documents to rehabilitate and implement recommended upgrades to the NF units, degasifiers, and odor control systems. The construction phase of this project is currently underway, and it is anticipated to be completed in September 2025.

**Staff Engineer, Lime Softening Chemical Building Renovation Needs Study, City of Boca Raton, Florida.**

The lime softening treatment process includes a chemical building (Building 11) that houses the lime storage silos, lime slakers, and other equipment, supporting systems, and functions. This comprehensive study on Building 11 was to identify and catalog the treatment process/mechanical functions provided by the building, investigate and document the existing electrical service and power distribution systems associated with the building, and evaluate the structural integrity of the building and associated structures and equipment, specifically the lime silos. Mr. Barba assisted the project manager by reviewing record documents, attending site visits, preparing figures and the report. This project was completed in August 2019.

**Project Engineer, BCWWS North Regional Reclaimed Water Treatment Plant Expansion, Broward County, Florida.**

This project includes design and construction of a 16.0 mgd expansion to the reclaimed water production systems (i.e., filter feed pumps, filters, chlorine contact basins, reclaimed water distribution pumps, chemical feed systems, and associated structural, electrical, instrumentation, and controls) for BCWWS's NRWTP. Mr. Barba was involved in permit coordination, preparation of application packages, and closeout of the project.

**Project Manager/Senior Engineer, Replacement of the Sodium Hypochlorite Storage Tanks Design and Construction, City of Boca Raton, Florida**

The City owns and operates six fiberglass reinforced plastic (FRP) sodium hypochlorite bulk storage tanks. Three tanks are designed to store 0.8% solution, two tanks are designed to store 12% solution, and one tank is a "swing-tank" that can store 0.8% or 12% solution. Mr. Barba served as the Project Manager and Senior Engineer during design development and construction for the replacement of the three 0.8% solution tanks and the "swing-tank". During construction, the City elected to rehabilitate the two 12% solution tanks via change order. This additional City requested work is currently underway and is anticipated to be completed in November 2025.

**Senior Engineer, Hidden Valley Pump Station Renovation, City of Boca Raton, Florida.**

This project includes the replacement of high service and jockey pumps, motors, and valves within the City's pump station, as well as the upgrade of the sodium hypochlorite generation system, the addition of an ammonia injection system, storage tank recirculation chemical injection/mixing system, and the installation of a storage tank pump-out/drain connection. Mr. Barba assisted with pump selection and the design of the chemical storage, feed, and recirculation mixing system. The design phase of the project is anticipated to be completed in the fourth quarter of 2025.

**Senior Engineer, Bipartisan Infrastructure Law (BIL) Emerging Contaminant Grants Drinking Water State Revolving Fund (DWSRF) Program, Multiple South Florida Municipalities.**

These projects included professional engineering services to prepare and submit planning and design loan request documentation to the DWSRF to procure federal grant funds under the BIL. While the DWSRF program refers to the funding as "loans," the funding under the emerging contaminants program qualifies for 100% principal forgiveness, effectively making it a grant program. Mr. Barba assisted with the preparation and submittal of Requests for Inclusion (RFIs), including supporting documentation including documentation of the subject contaminant levels in water supplies. Once the projects were priority listed, Mr. Barba assisted with the loan agreement application process. Mr. Barba's team secured nearly \$30 million in EC grant funding for MBC's municipal drinking water clients.

**Project Manager/Engineer of Record, Storage Tanks Inspection and Rehabilitation, City of Boca Raton, Florida.**

The City owns and operates nine prestressed concrete ground storage tanks that are used to store treated potable water (five tanks), reclaimed water (three tanks), and secondary wastewater effluent (one tank). The City also owns and operates two potable elevated steel tanks. The City desired to rehabilitate the storage tanks and inspect the tanks in accordance with the Florida Administrative Code. Mr. Barba served as project manager and engineer of record on this project.

**Senior Engineer, Drinking Water State Revolving Fund (DWSRF) Program, City of Pompano Beach, Florida.** This project includes professional engineering services to prepare and submit documentation to the DWSRF procure loan funding for the C-51 Reservoir Capacity Allocation project. Due to the nature of the project, which was designated as an alternative water supply by the South Florida Water Management District, MBC prepared an EPA Water Rights Class Deviation request. Having obtained the EPA class deviation, the project was then eligible for funding under the DWSRF program. Mr. Barba assisted the City in procuring DWSRF loan funding as well as loan agreement compliance.

**Senior Engineer, Clean Water State Revolving Fund (CWSRF) Program, City of Pompano Beach, Florida.** This project included professional engineering assistance to prepare and submit documentation to the CWSRF to procure loan funding for select projects and for assistance in complying with SRF funding requirements during construction. Mr. Barba assisted the Project Manager and the City in procuring funding for nine stormwater construction projects, three stormwater design projects, and one sewer construction project.

**Project Manager, Broward County Surtax Grant Compliance, City of Pompano Beach, Florida.** This project includes compliance assistance with an interlocal agreement between Broward County and the City and the Mobility Advancement Program (MAP) for two stormwater construction projects. The City of Pompano Beach has been approved for Surtax funding for projects during Cycle 1 of the program. Mr. Barba serves as Project Manager for the Surtax program compliance services during construction which consists of preparation and coordination of pre-construction documentation submittals, followed by monthly and quarterly project progress submittals, and financial reconciliation to the grant amount for the duration of the construction project.

**Project Manager, Procurement of SRF Funding and Compliance Services During Construction, Water System Interconnect Upgrades, City of Pompano Beach, Florida.** This project included the upgrade of four potable water system interconnects within the City's service area. Mr. Barba served as a Project Engineer during design and funding procurement. After successfully procuring Drinking Water State Revolving Fund (DWSRF) funding for the construction phase of the project, Mr. Barba served as Project Manager during construction and provided construction contract administration, SRF and appropriations grant funding compliance services. Funding compliance services included review of American Iron and Steel certification submittals, performance and review of labor interviews, review of Contractor pay requests and certified payrolls, preparation of SRF and appropriations grant payment disbursement requests, and close-out assistance.

**Project Engineer, Florida Department of Environmental Protection (FDEP) Water Quality Grant Program, City of Pompano Beach, Florida.** The FDEP Water Quality Grant Program provides eligible entities with grant funding opportunities to prioritize improved water quality. This program includes various categories of grant funding for wastewater, innovative technologies, springs, resiliency, planning, water quality, and hurricane stormwater/wastewater remediation related projects. Mr. Barba served as Project Engineer to prepare and submit grant applications under multiple categories of the FDEP Water Quality Grant Program.

**Staff Engineer Intern, Seminole Tribe of Florida Hollywood Raw Water Supply Improvements, Hollywood, Florida.** This project included installation of well pumps and approximately 1,050 linear feet of raw water main (8" to 16" diameter) from the new pumps to the existing water main at the Hollywood Reservation Water Treatment Plant. Each well head is per STOF's standard design including valve train with flow metering and adjacent control and power panels. Standby power is provided to the well pumps from existing generators at the treatment plant. A new acid injection point was installed to serve the new wells. Mr. Barba assisted the project manager by reviewing record documents, preparing construction documents, and designing components for the addition new raw water wells and pumping systems. Mr. Barba provided engineering services during construction including; construction contract administration, resident project representation, and pump start-up testing and analysis.

**Staff Professional, BCWWS Pump Station 3A Demonstration and Design of 4-Log Virus Treatment, Broward County, Florida.** MBC was authorized to prepare the Demonstration of Four-Log Virus Treatment of Groundwater package for submittal to the Florida Department of Health – Broward County (FDHBC) and Florida Department of Environmental Protection (FDEP). BCWWS received conceptual approval from the FDHBC of the Demonstration submittal and proposed treatment protocol for the facility to comply with the subject treatment requirements under the Federal GWR. Mr. Barba was responsible for drafting construction documents, assisting the project manager in developing a water quality and treatability study, and start-up testing.

**Senior Engineer, Water Treatment Plant Nos. 3 and 9 Process Improvements, Palm Beach County, Florida.** As a subconsultant to the Prime, MBC is providing professional engineering services for design of miscellaneous improvements to Water Treatment Plants No. 3 and 9. MBC's scope of services includes modifications to the existing sodium hydroxide bulk storage and chemical feed system, addition of a bridge crane (for maintenance of the membrane feed and high service pumps), demolition and replacement of the scavenger tank associated with the membrane cleaning system, expanding the capacity of the existing diesel fuel storage system, and improvements to the corrosion inhibitor system. Mr. Barba has prepared a preliminary design report and is leading the design effort for the development of construction contract documents to implement the modifications described above.

## Publications

“Upgrading and Renewing a 20 year old 40 MGD Nanofiltration Plant” (Co-Presenter and Co-Author) *AMTA Membrane Technology Conference and Exposition*, West Palm Beach, Florida, March 2024.

“Ending Pretreatment Chemical Dependency at a 10 MGD Nanofiltration Plant” *AMTA Membrane Technology Conference and Exposition*, Knoxville, Tennessee, February 2023.

"Optimizing Chemical Pretreatment and Membrane Element Performance at a 10 MGD Nanofiltration Plant" (Co-Presenter and Co-Author) *AMTA Membrane Technology Conference and Exposition*, West Palm Beach, Florida, July 2021.

“Optimizing Chemical Pretreatment for a 10 mgd Nanofiltration Plant” (Co-Author) *AMTA Membrane Technology Conference and Exposition*, Phoenix, AZ March 2020.

“Upgraded Disinfection: Providing Four-Log Virus Treatment of a Finished Water Supply for a Consecutive System”(Co-Author) FSAWWA, Orlando, Florida, November 2016

## Professional History

2015 to 2021 - 2022 to Current      *McCafferty Brinson Consulting, LLC - Fort Lauderdale, Florida*

2021 to 2022      *Environmental Partners – Boston, Massachusetts*



**Audra McCafferty, P.E., ENV SP**  
Assistant Project Manager and Funding Lead



#### Experience Highlights

Ms. McCafferty has more than 30 years of experience in general environmental consulting and is co-founder of McCafferty Brinson Consulting, LLC. Specialties include drinking water and wastewater facilities design, environmental related projects, regulatory compliance strategies, permitting, cost estimating scheduling, and funding acquisition and compliance.

#### Education

B.S. – Environmental Engineering,  
University of Florida, 1991

#### Professional Registration

State of Florida  
Professional Engineer No. 54737

#### Professional Certifications

ENV SP-ISI Envision Sustainability  
Professional

LEED BD+C Accredited  
Professional

#### Professional Society Memberships

Institute for Sustainable  
Infrastructure Member

Southeast Florida Utility Council  
(SEFLUC)

**SRF Funds Allocated**  
\$112 million in loans  
\$42 million in grants

## Professional Experience

Ms. McCafferty is an environmental engineer with over thirty years of experience. Ms. McCafferty has a major role in the day-to-day operation of the company while maintaining her technical role as Principal Engineer. Her experience includes environmental consulting, environmental and utility permitting, grant and loan funding procurement and compliance, regulatory compliance, environmental assessments, and water, wastewater, and reuse facility design. The following are some representative technical projects in which Ms. McCafferty has been involved.

## Project Experience

**Funding Coordinator, Water Treatment Plant Emerging Contaminants Design Upgrades, City of Pompano Beach, Florida.** The City has received an SRF planning and design loan under the emerging contaminants funds under Bipartisan Infrastructure Law. MBC assisted the City with preparation and submittal of the planning document in 2024. MBC is currently designing the improvements listed in the planning document. The project consists of the expansion of the City's existing 10 million gallon per day capacity nanofiltration (NF) process to 30 mgd to meet the City's projected buildout maximum day demands, and installation of the second concentrate disposal deep injection well. Ms. McCafferty serves as the funding lead for this project, successfully coordinating and assisting the City with procuring \$30 million in Drinking Water State Revolving Fund (DWSRF) funding with \$6 million principal forgiveness. The design phase of the project is anticipated to be completed in March 2026.

**Project Manager, City of Pompano Beach Water Treatment Plant Emerging Contaminants Upgrades Planning Document, Pompano Beach, Florida.** In March 2023, the USEPA proposed a National Primary Drinking Water Regulation (NPDWR) for certain per- and polyfluoroalkyl substances (PFAS) with an estimated compliance date of December 2026. Under the 2021 Bipartisan Infrastructure Law (BIL), Federal grant funds were made available to drinking water utilities for implementation of water treatment plant upgrades that are necessary to provide compliance with the proposed PFAS regulations. Ms. McCafferty assisted the City in securing a grant (loan with 100% principal forgiveness) in the amount of \$9,595,000 for PFAS-related upgrades to the City's water treatment plant. This grant/loan program is administered by the State of Florida Drinking Water State Revolving Fund (DWSRF) program. One of the most critical funding document submittals is the Facilities Plan and Planning Document, which provide the definition of the project (i.e., identification of the most cost-effective treatment technology to be utilized) for approval by the DWSRF prior to award of the final design funding. Ms. McCafferty provided critical guidance to the City with timely completion of the grant acquisition and planning document development.

**Project Manager, Bipartisan Infrastructure Law (BIL) Emerging Contaminant Grants Drinking Water State Revolving Fund (DWSRF) Program, Multiple South Florida Municipalities.** These projects included professional engineering services to prepare and submit planning and design loan request documentation to the DWSRF to procure federal grant funds under the BIL. While the DWSRF program refers to the funding as “loans,” the funding under the emerging contaminants program qualifies for principal forgiveness, effectively making it a grant program. Ms. McCafferty served as Project Manager for the preparation and submittal of Requests for Inclusions (RFI) including supporting documentation with special emphasis on providing emerging contaminant evidence. Once the projects were priority listed, Ms. McCafferty assisted each sponsor with the submittal of loan agreement application process, to include submittal of the loan agreement, Authoring Resolution and numerous EPA required forms.

**Principal Engineer, CWSRF/DWSRF Construction Phase SRF Capital Funding Administrative and Compliance Assistance Services, City of Hollywood.** This project includes professional engineering assistance to the prime engineering consultant with SRF loan administrative and program compliance. The project, Deep Injection Wells No. 3 and No. 4 Pump Station, has secured \$94 million in funding under both the CWSRF and DWSRF programs. Ms. McCafferty serves as Principal Engineer to oversee SRF compliance services during construction which consists of review of project records, American Iron and Steel certification submittals, review of labor interviews, pay request and certified payroll. Upon review of the above submittals, MBC develops logs of submitted documentation and discrepancy logs to assist the City with compliance with the terms of the SRF loan agreement.

**Principal Engineer, Broward County Surtax Grant Compliance, City of Pompano Beach.** This project includes compliance assistance with an interlocal agreement between Broward County, the City, and the Mobility Advancement Program (MAP) for two stormwater construction projects. The City of Pompano Beach has been approved for Surtax grants for projects during Cycle 1 of the program. MBS assisted the City with project selection and preparation of grant applications for three stormwater construction grants under Cycle 5 of the program. Ms. McCafferty serves as Principal Engineer to oversee Surtax grant program compliance services during construction which consists pre-construction documentation submittals, followed by monthly and quarterly project progression and financial reconciliation to the grant amount for the duration of the construction project.

**Project Manager, Procurement of SRF Funding and Compliance Services During Construction, Water System Interconnect Upgrades, City of Pompano Beach.** This project included the upgrade of four potable water system interconnects within the City’s service area. Ms. McCafferty served as Project Manager during procurement of DWSRF loan with partial principal forgiveness for the construction phase of the project. The project received grant funding in the form of partial loan forgiveness from the DWSRF program. Additional grant funding for this project was received from the FDEP appropriations program under Ms. McCafferty’s oversight.

**Project Manager, Clean Water State Revolving Fund (CWSRF) Program, City of Pompano Beach.** This project included professional engineering assistance to prepare and submit documentation to the CWSRF to procure loan funding for select projects and for assistance in complying with SRF funding requirements during construction. Ms. McCafferty assisted the City in procuring \$26 million in loan funding for nine stormwater construction projects, three stormwater design projects, and one sewer construction project.

**Project Manager, Drinking Water State Revolving Fund (DWSRF) Program, City of Pompano Beach.** This project includes professional engineering services to prepare and submit documentation to the DWSRF to procure \$9.2 million funding for the C-51 Reservoir Capacity Allocation project. Due to the nature of the project, which was designated as an alternative water supply by the South Florida Water Management District, Ms. McCafferty assisted the City with an EPA Water Rights Class Deviation request. Having obtained the EPA class deviation, the project was then eligible for funding under the DWSRF program. Ms. McCafferty assisted the City in procuring DWSRF loan funding as well as loan agreement compliance.

**Principal Engineer, BCWWS WTP 3A Treatability Study, Four-Log Virus treatment System, and Demonstration, Broward County, Florida.** MBC was authorized to prepare the Demonstration of Four-Log Virus Treatment of Groundwater package for submittal to the Florida Department of Health – Broward County (FDHBC) and Florida Department of Environmental Protection (FDEP). BCWWS received conceptual approval from the FDHBC of the Demonstration submittal and proposed treatment protocol for the facility to comply with the subject treatment requirements under the Federal GWR. Ms. McCafferty was responsible for developing and implementing testing protocol, permitting and compliance services. This study served as the basis of design for achieving four-log virus treatment for District 3A.

**Principal Engineer, Membrane Element Replacement Pompano Beach, Florida.** This project included the replacement of the 1,820 nanofiltration (NF) membrane elements in the 10 million gallon per day (mgd) capacity NF process at the City's water treatment plant. Plot testing of membrane element selection from membrane element manufactures (MEM) for prequalification for bidding and to optimize the chemical pretreatment protocol and element selection. Ms. McCafferty was responsible for the permitting of a 2:1 array pilot test unit utilizing 8-inch diameter, seven-element (full size) membrane pressure vessels, and engineering assistance during bidding. This project reached final completion in May 2020.

**Principal Engineer, Lime Softening Chemical Building Renovation Needs Study, City of Boca Raton, Florida.** The lime softening treatment process includes a chemical building (Building 11) that houses the lime storage silos, lime slakers, lime feed equipment, a coagulant storage, preparation, and feed system, as well as other associated supporting systems and functions. This complete comprehensive study on Building 11 identified and cataloged the treatment process/mechanical functions provided by the building, investigated and documented the existing electrical service and power distribution systems associated with the building, and evaluated the structural integrity of the building and associated structures and equipment, specifically the lime silos. Ms. McCafferty was responsible for preparing the report.

**Project Manager, Country Club Village Infrastructure Upgrades (iSIP), City of Boca Raton, Florida.** This project consisted of the relocation and upsizing of approximately 35,000 linear feet of existing domestic water mains from the rear yards to rights-of-ways, installation of approximately 2,500 of 16-inch water main, removal and replacement of sidewalks, roadways, ramps, and the improvement of three stormwater outfalls. Ms. McCafferty is MBC's manager for development of the sidewalk replacement effort, development of technical specifications for the bid package, and permitting for the project with several state and local agencies.

**Principal Engineer, Membrane Pretreatment Pressure Filters Rehabilitation and Improvements Design and Services During Construction, City of Boca Raton, Florida.** This project included the replacement of the existing valve actuators and the updated backwash air inlet check valves, air release valves and filter media in six filter, installation of a drain loop and drain valve in the existing main steel air feed piping; along with other renewal and replacement activities and electrical and I&C improvements. This project reached final completion in August 2019. Ms. McCafferty was responsible for engineering assistance during bidding, various construction contract administration services, and permitting and compliance services.

**Principal Engineer, Lime Softening Backwash and Disinfection Upgrades, City of Boca Raton, Florida.** This project includes the addition of filter-to-waste piping and control valves to route the filter effluent to the washwater recovery basin, the installation of underground 48-inch diameter bypass piping that allows lime softening process clearwells to bypass the Building No. 5 transfer pump station and utilize the Building No. 7 transfer pumps, and implementation of clearwell modifications to provide optimized four-log virus disinfection as demonstrated and conceptually approved by the Florida Department of Health in Palm Beach County (FDHPBC) under the Water Treatment Plant Four-Log Virus Treatment Reassessment and Demonstration Project. Ms. McCafferty is responsible for permitting, assisting with developing technical specifications, and providing bidding services.



**Mariell Soto, P.E., CDT**  
Engineer II and Design Lead



#### Experience Highlights

Ms. Soto has experience in designing water treatment plant components and providing construction contract administration.

#### Education

B.S. – Environmental Engineering, Florida International University, 2017

#### Professional Registration

State of Florida  
Professional Engineer  
License No. 96896

#### Professional Certifications

Construction Document Technologist (CDT)

#### Publications

"Upgrading and Renewing a 20 Years Old 40 MGD Nanofiltration Plant" (Co-Presenter and Co-Author) AWWA/AMTA MTC, West Palm Beach, Florida, March 2024.

## Professional Experience

Ms. Mariell Soto is a project engineer whose responsibilities include project management, process mechanical design, drafting, permitting, preparation of technical memorandums and construction contract documents, funding assistance, construction contract administration services, and resident project representation services. She has been involved in various potable water and reclaimed water and wastewater treatment plants, and collection/distribution system related projects.

## Project Experience

**Project Engineer/Design Lead, Water Treatment Plant Emerging Contaminants Design Upgrades, City of Pompano Beach, Florida.** The City has received an SRF planning and design loan under the emerging contaminants funds under Bipartisan Infrastructure Law. MBC assisted the City with preparation and submittal of the planning document in 2024. MBC is currently designing the improvements listed in the planning document. The project consists of the expansion of the City's existing 10 million gallon per day capacity nanofiltration (NF) process to 30 mgd to meet the City's projected buildout maximum day demands, and installation of the second concentrate disposal deep injection well. Ms. Soto serves as the project engineer and as the design lead for this project, using advanced 3D LiDAR technology to capture precise data scans, integrate them with the future work plans, and produce highly accurate 3D representations of clearwells and piping. These scans are translated using Revit, ReCap, and BIM 360 for rendering and developing engineering construction drawings. The design phase of the project is anticipated to be completed in March 2026.

**Project Engineer, Glades Road Water Treatment Plant Expansion and Rehabilitation of the Membrane Pretreatment Pressure Filters, City of Boca Raton, Florida.** The expansion and rehabilitation projects included the addition of two new 10-foot diameter by 41-foot long, two-cell steel pressure filters, similar in design to the existing pressure filters, with all required face piping, fittings, valves, electric valve operators, electrical systems, instrumentation, and controls. The rehabilitation efforts involved the replacement of valve actuators, backwash air inlet check valves, air release valves, and filter media in six filter cells, installation of a drain loop and drain valve in the existing main steel air feed piping, and other renewal and replacement activities, as well as electrical and instrumentation and control improvements. Additionally, three gravity filters were rehabilitated, including media replacement and inspection. Ms. Soto assisted with preparation of construction documents during design and provided services during construction including resident project representation, pump start-up testing and analysis, review of contractor's submittals, requests for information, and pay applications.

**Project Engineer, Four-Log Virus Treatment Upgrades Study, Design, and Construction, City of Boca Raton, Florida.** This project included the investigation and evaluation of alternatives for optimizing four-log virus treatment relative to disinfection by-product formation, as well as final design and construction of the necessary improvements associated with the selected alternative. The selected alternative included the addition of channel mixers and intra-basin baffles within the lime softening process clearwells, relocation of the sodium hypochlorite and ammonia injection points, and the relocation of the free chlorine, temperature, and pH sample points for four-log virus treatment compliance monitoring. In addition to the disinfection-related upgrades, the design included the addition of filter-to-waste piping and control valves to route the filter effluent to the washwater recovery basin, as well as yard piping modifications to improve operational flexibility and reliability. Ms. Soto served as a project engineer during design and is currently providing engineering services during construction.

**Project Engineer, City of Pompano Beach Water Treatment Plant Emerging Contaminants Upgrades Facilities Plan, Pompano Beach, Florida.** In March 2023, the USEPA proposed a National Primary Drinking Water Regulation (NPDWR) for certain per- and polyfluoroalkyl substances (PFAS). Under the 2021 Bipartisan Infrastructure Law (BIL), Federal grant funds were made available to drinking water utilities for implementation of water treatment plant upgrades that are necessary to provide compliance with the proposed PFAS regulations. MBC assisted the City in securing a grant in the amount of \$9,595,000 for PFAS-related upgrades to the City's water treatment plant. This grant/loan program is administered by the State of Florida Drinking Water State Revolving Fund (DWSRF) program. Ms. Soto served as co-author for the DWSRF Facilities Plan in conformance with applicable DWSRF funding requirements. The Facilities Plan included a treatment technology upgrades alternative analysis considering nanofiltration (NF) and reverse osmosis (RO) membrane treatment, granular activated carbon (GAC), and anion exchange (AIX) for removal of PFAS, as well as development of conceptual designs and capital and operation and maintenance (O&M) cost estimates for each technology alternative. The study included on-site pilot testing of the GAC and AIX technologies. (Pilot testing of membranes was not necessary because the City's full-scale NF facility provided sufficient operating data necessary for the analysis.)

**Project Engineer, Nanofiltration Unit and Degasifier Upgrades, City of Boca Raton, Florida.** Based on the findings outlined in the Membrane Softening Process Renovation Needs Study, the City has undertaken a Water Treatment Plant Upgrades program to complete a comprehensive renovation of all major components of the Glades Road Water Treatment Plant, membrane softening process equipment, pumping and storage facilities, power supply and distribution and control systems, and plant infrastructure over a ten-year period. This project was identified in the Needs Study, and Ms. Soto was responsible for the preparation of construction contract documents and provides engineering services during construction, including construction contract administration and resident project representation. The construction phase of this project is currently underway, and it is anticipated to be completed in September 2026.

**Project Engineer, Glades Road Water Treatment Plant, Washwater Recovery Upgrades, City of Boca Raton, Florida.** The Glades Road Water Treatment Plant lime softening process utilizes a washwater recovery basin and return pump system for the treatment (settling) and recycle of filter backwash water and other recyclable treatment process streams. The existing washwater recovery basin was over 35 years old and under this project MBC was authorized to design a new 575,000-gallon octagonal concrete washwater recovery basin with improved process capabilities (supernatant decanting system and a dedicated pump station for a settled sludge handling and washwater return pump system). Ms. Soto provided engineering services during construction, including construction contract administration and resident project representation.

**Project Manager, Hidden Valley Pump Station Renovation Design, City of Boca Raton, Florida** This project includes the replacement of pumps, motors, and valves within the City's pump station, as well as the upgrade of the sodium hypochlorite generation system, the addition of an ammonia injection system, the relocation of the hypochlorite injection point, and the installation of a storage tank pump-out. Ms. Soto is serving as project manager on this project. The design phase will be completed in November 2024.

**Project Engineer, Continuing Nanofiltration Process Optimization Services, City of Boca Raton, Florida.** Since January 2008 MBC has provided continuing process technical services that include quarterly review of the membrane process performance data, plant operating records, wellfield operating records, operating practices, and preparation of quarterly reports on the findings of MBC's review, including recommendations for improvements in operating practices and data collection for optimization of the treatment process and improvements in plant efficiency and reliability. Ms. Soto assisted the project manager with the preparation of data analysis and graphics for the quarterly water treatment plant performance reports.

**Project Engineer, Water Treatment Plant Nos. 3 and 9 Process Improvements, Palm Beach County, Florida.** As a subconsultant to the Prime, MBC is providing professional engineering services for design of miscellaneous improvements to Water Treatment Plants No. 3 and 9. MBC's scope of services includes modifications to the existing sodium hydroxide bulk storage and chemical feed system, addition of a bridge crane (for maintenance of the membrane feed and high service pumps), demolition and replacement of the scavenger tank associated with the membrane cleaning system, expanding the capacity of the existing diesel fuel storage system, and improvements to the corrosion inhibitor system. Ms. Soto has prepared a preliminary design report and is leading the design effort for the development of construction contract documents to implement the modifications described above.

**Staff Engineer, Membrane Softening Process Renovation Needs Study, City of Boca Raton, Florida.** This project included evaluation of the City's 40-mgd capacity membrane softening facility that was placed online in 2004. Since the original commissioning of the plant, the process equipment, support systems and associated structures had aged and were in need of normal repair, renewal, and replacement. The comprehensive study identified necessary improvements and upgrades to extend the service life of the plant and improve operational flexibility, process efficiency, and overall reliability. The study grouped the proposed upgrades into individual projects for implementation (final design and construction). Ms. Soto assisted the project manager by reviewing record documents and preparing figures for the report.

**Staff Engineer, Lime Softening Chemical Building Renovation Needs Study, City of Boca Raton, Florida.** The lime softening treatment process includes a chemical building (Building 11) that houses the lime storage silos, lime slakers, and other equipment, supporting systems, and functions. This comprehensive study on Building 11 identified and cataloged the treatment process/mechanical functions provided by the building, investigated and documented the existing electrical service and power distribution systems associated with the building, and evaluated the structural integrity of the building and associated structures and equipment, specifically the lime silos. Ms. Soto assisted the project manager by reviewing record documents, processing data, and preparing figures for the report.

**Staff Engineer, Clean Water State Revolving Fund (CWSRF) Program, City of Pompano Beach.** This project included professional engineering assistance to prepare and submit documentation to the CWSRF to procure loan funding for select projects and for assistance in complying with SRF funding requirements during construction. Ms. Soto assisted the Project Manager and the City in procuring approximately \$24 million in funding for nine stormwater construction projects, three stormwater design projects, and one sewer construction project.

Mariell Soto, P.E., CDT

Page 4

**Staff Engineer, Drinking Water State Revolving Fund (DWSRF) Program, City of Pompano Beach.** This project includes professional engineering services to prepare and submit documentation to the DWSRF to procure a \$9.2 million loan for the C-51 Reservoir Capacity Allocation project. Due to the nature of the project, which was designated as an alternative water supply by the South Florida Water Management District, MBC prepared an EPA Water Rights Class Deviation request. Having obtained the EPA class deviation, the project was then eligible for funding under the DWSRF program. Ms. Soto assisted the City in procuring DWSRF loan funding as well as assistance with the loan agreement execution process.

**Staff Engineer, BCWWS Corrosion Control Study for District 1 and 2, Broward County, Florida.** Ms. Soto assisted the project manager in developing water quality data and a treatability study. This includes estimating the theoretical solubility of lead and copper, calcium carbonate related indices (LSI, CCPP, and RI), and the dissolved inorganic carbon, which was analyzed to select an optimum corrosion control treatment.

## Publications

“Upgrading and Renewing a 20 year old 40 MGD Nanofiltration Plant” (Co-Presenter and Co-Author) *AMTA Membrane Technology Conference and Exposition*, West Palm Beach, Florida, March 2024.

## Professional History

2018 to Current *McCafferty Brinson Consulting, LLC – Fort Lauderdale, Florida*

2018 to 2018 *Unipharma – Tamarac, Florida*



**Mathew A. Marsh, CGC, PMP**  
Construction Manager



#### Experience Highlights

Mr. Marsh has experience in the project delivery of water and wastewater treatment plant components and providing consultant services.

#### Education

B.S. – Surveying Management,  
Everglades University

A.S. – Civil Engineering  
Technology, Indian River State  
College

A.S. – Drafting & Design  
Technology, Indian River State  
College

#### Professional Licensure / Registrations

CGC – Certified General  
Contractor.  
License Certification ID No.  
CGC1535679

PMI-PMP - Project Management  
Professional,  
Registration ID No. 2860819

## Professional Experience

Mr. Marsh serves as MBC's construction department and safety program leader. He is a Construction Manager with twenty-eight years of experience in complex environments. He is licensed as a General Contractor, has expertise in construction trades, contract administration, managing field operations, and construction project delivery. Specialties include construction of water and wastewater treatment processes, water conveyance structures, operations facilities, and utility infrastructure. The following are representative projects in which he has been involved.

## Project Experience

**Construction Manager, Nanofiltration Unit and Degasifier Upgrades, City of Boca Raton, Florida.** Based on the findings outlined in the Membrane Softening Process Renovation Needs Study, the City has undertaken a Water Treatment Plant Upgrades program to complete a comprehensive renovation of all major components of the Glades Road Water Treatment Plant, membrane softening process equipment, pumping and storage facilities, power supply and distribution and supervisory control and data Acquisition (SCADA) systems, and plant infrastructure over a ten-year period. Mr. Marsh provides construction contract administration and resident project representation services which includes review of contractor schedules, submittals, pay applications, cost proposals, and requests for information, preparation of requests for proposals, work change directives, and change orders, and field observation that entail coordination with subconsultants and specialty inspectors.

**Construction Manager, Four-Log Virus Treatment Upgrades Study, Design, and Construction, City of Boca Raton, Florida.** This project includes the investigation and evaluation of alternatives for optimizing four-log virus treatment relative to disinfection by-product formation, as well as final design and construction of necessary improvements associated with the selected alternative. The selected alternative included the addition of channel mixers and intra-basin baffles within the lime softening process Clearwell's, relocation of the sodium hypochlorite and ammonia injection points, and the relocation of the free chlorine, temperature, and pH sample points for four-log virus treatment compliance monitoring. In addition to the disinfection-related upgrades, the design included the addition of filter-to-waste piping and control valves to route the filter effluent to the wash-water recovery basin, as well as yard piping modifications to improve operational flexibility and reliability. Mr. Marsh provides construction contract administration and resident project representation services which includes review of contractor schedules, submittals, pay applications, cost proposals, and requests for information, preparation of requests for proposals, work change directives, and change orders, and field observation that entail coordination with subconsultants and specialty inspectors.

**Construction Manager, Replacement of the Sodium Hypochlorite Storage Tanks, City of Boca Raton, Florida.** The City observed degradation to the corrosion barriers inside two of the six existing Fiberglass reinforced plastic sodium hypochlorite storage tanks. These two tanks were inspected to determine the feasibility of repair and rehabilitation under the City's Storage Tanks Inspection and Rehabilitation Project. Based on the findings of the inspection, the City elected to proceed with the replacement of four of the six existing sodium hypochlorite storage tanks under this project. Mr. Marsh provided construction contract administration and resident project representation services which includes review of contractor schedules, submittals, pay applications, cost proposals, and requests for information, preparation of requests for proposals, work change directives, and change orders, and field observation that entail coordination with subconsultants and specialty inspectors.

**Construction Associate, Glades Road Water Treatment Plant, Washwater Recovery Upgrades, City of Boca Raton, Florida.** The Glades Road Water Treatment Plant lime softening process utilizes a washwater recovery basin and return pump system for the treatment (settling) and recycle of filter backwash water and other recyclable treatment process streams. The existing washwater recovery basin was over 35 years old and under this project MBC was authorized to design a new 575,000-gallon octagonal concrete washwater recovery basin with improved process capabilities (supernatant decanting system and a dedicated pump station for a settled sludge handling and washwater return pump system). Mr. Marsh provided construction contract administration and resident project representation services which includes review of contractor schedules, submittals, pay applications, cost proposals, and requests for information, preparation of requests for proposals, work change directives, and change orders, and field observation that entail coordination with subconsultants and specialty inspectors.

**Construction Associate, Glades Road Water Treatment Plant, Membrane Pretreatment Pressure Filter System Expansion, City of Boca Raton, Florida.** The City desired to expand the capacity of the existing pressure filter system through the addition of two new 10-foot diameter by 41-foot long, two-cell steel pressure filters, that are similar in design to the existing pressure filters, with all required internals, face piping, fittings, valves, electric valve operators, electrical systems, instrumentation, and SCADA. Mr. Marsh provided construction contract administration and resident project representation services which includes review of contractor schedules, submittals, pay applications, cost proposals, and requests for information, preparation of requests for proposals, work change directives, and change orders, and field observation that entail coordination with subconsultants and specialty inspectors.

**Construction Associate, Storage Tanks Inspection and Rehabilitation, City of Boca Raton, Florida.** The City owns and operates nine prestressed concrete ground storage tanks that are used to store treated potable water (five tanks), reclaimed water (three tanks), and secondary wastewater effluent (one tank). The City also owns and operates two potable water elevated steel tanks. The City desired to rehabilitate and inspect the storage tanks in accordance with the Florida Administrative Code. Mr. Marsh provided construction contract administration and resident project representation services which included review of contractor schedules, submittals, pay applications, cost proposals, and requests for information, preparation of requests for proposals, work change directives, and change orders, and field observation that entailed coordination with subconsultants and specialty inspectors.

**Construction Associate, Potable Water Interconnect Upgrades Design and Construction Phase Services, City of Pompano Beach, Florida.** The City owns and operates a water system consisting of a 50 million gallon per day (mgd) capacity water treatment plant, finished water storage, high service pump system, and a finished water transmission/distribution system that provides water service to the customers within the City's water service area. The project consisted of upgrades of four potable water interconnects with various neighboring municipalities. Mr. Marsh provided construction contract administration and lead resident project representation services that entailed coordination with subconsultants, multiple stakeholders, and specialty inspectors.

**Construction Associate, Reclaimed Water Treatment Plant Piping Modifications City of Pompano Beach, Florida. Construction Associate, Reclaimed Water Treatment Plant Piping Modifications City of Pompano Beach, Florida.** This project included installation of piping to allow the reclaimed water storage tanks to be filled with potable water to supplement the reclaimed water production during periods when the plant's production cannot meet demands, modifications to existing filter bypass return piping, replacement of three existing low pressure distribution pumps, and installation of two additional low pressure distribution pumps and two filter feed pumps in existing pump suction barrels. Mr. Marsh provided construction contract administration and lead resident project representation services that entailed coordination with subconsultants and specialty inspectors.

## Professional Society Memberships

American Society of Civil Engineers (ASCE)  
 Construction Specifications Institute (CSI)  
 Project Management Institute (PMI)  
 Board of Certified Safety Professionals (BCSP)  
 Associated General Contractors of America (AGC)

Construction Management Association of America (CMAA)  
 American Institute of Constructors (AIC)  
 American Concrete Institute (ACI)  
 Utility Engineering and Surveying Institute (UESI)

## Professional History

*2021 to Current McCafferty Brinson Consulting LLC – Fort Lauderdale, Florida*

*2020 to 2021 Amentum – Afghanistan (Amentum acquired DynCorp International in November 2020)*

*2019 to 2020 DynCorp International LLC. – Afghanistan*

*1997 to 2018 Various Construction Projects Involvement – South Florida*



## Apoorva Taduri

### Senior Field Coordinator



#### Experience Highlights

Ms. Taduri has experience in senior field coordination for water treatment plant construction and quantity surveying for infrastructure projects.

#### Education

B.S. – Civil Engineering,  
Jawaharlal Nehru Technological  
University Hyderabad

M.S. – Civil Engineering, Florida  
Atlantic University

Post Graduate Diploma – Quantity  
Surveying and Contracts  
Management, National Academy  
of Construction

#### Training

OSHA 30-Hour Construction  
Safety and Health

## Professional Experience

Ms. Taduri serves as MBC's Senior Field Coordinator. She provides resident project representation services during construction for water treatment plant projects. Her responsibilities include daily field observation reporting, verification of contract compliance, and field coordination with contractors and City representatives. The following are some representative projects in which Ms. Taduri has been involved.

## Project Experience

**Senior Field Coordinator, Four- Log Virus Treatment Upgrades Study, Design, and Construction, City of Boca Raton, Florida** This project included the investigation and evaluation of alternatives for optimizing four-log virus treatment relative to disinfection by-product formation, as well as final design and construction of the necessary improvements associated with the selected alternative. The selected alternative included the addition of channel mixers and intra-basin baffles within the lime softening process clearwells, relocation of the sodium hypochlorite and ammonia injection points, and the relocation of the free chlorine, temperature, and pH sample points for four-log virus treatment compliance monitoring. In addition to the disinfection-related upgrades, the design included the addition of filter-to-waste piping and control valves to route the filter effluent to the washwater recovery basin, as well as yard piping modifications to improve operational flexibility and reliability. Ms. Taduri is responsible for construction administration support, field observations, verification of work in accordance with contract documents, field coordination, and project reporting. Her duties include assisting in reviews of contractor progress schedules, shop drawings, RFIs, and pay application reviews, along with tracking daily construction progress, documenting deviations, and facilitating quality assurance. The construction phase of this project is ongoing and is anticipated to be completed in November 2025.

**Senior Field Coordinator, Nanofiltration Unit and Degasifier Upgrades, City of Boca Raton, Florida.** Based on the findings outlined in the Membrane Softening Process Renovation Needs Study, the City has undertaken a Water Treatment Plant Upgrades program to complete a comprehensive renovation of all major components of the Glades Road Water Treatment Plant, membrane softening process equipment, pumping and storage facilities, power supply and distribution and control systems, and plant infrastructure over a ten-year period. Ms. Taduri is responsible for construction administration support, field observations, verification of work in accordance with contract documents, field coordination, and project reporting. Her duties include assisting in reviews of contractor progress schedules, shop drawings, RFIs, and pay application reviews, along with tracking daily construction progress, documenting deviations, and facilitating quality assurance. The construction phase of this project is currently underway, and it is anticipated to be completed in September 2026.

**Amanda T. Esposito**  
Staff Professional



#### Experience Highlights

Designing water treatment plant components utilizing Computer-Aided Design software such as Revit, AutoCAD 2D, and AutoCAD Plant 3D providing construction contract administration, and data analysis.

#### Education

B.S. – Mechanical Engineering,  
Florida International University,  
2024

OSHA Safety Training Certification

Confined Spaced Training  
Certification

## Professional Experience

Ms. Esposito serves as a designer and staff professional whose responsibilities include assisting in the process of mechanical design for water and wastewater treatment facilities, permitting, preparation of engineering documents, drawings, and technical specifications, and construction contract administration services. She has been involved in potable water, reclaimed water, water treatment plant improvements, and stormwater related projects.

## Project Experience

**Staff Professional, Water Treatment Plant Emerging Contaminants Design Upgrades, City of Pompano Beach, Florida.** The City has received an SRF planning and design loan under the emerging contaminants funds under Bipartisan Infrastructure Law. MBC assisted the City with preparation and submittal of the planning document in 2024. MBC is currently designing the improvements listed in the planning document. The project consists of the expansion of the City's existing 10 million gallon per day capacity nanofiltration (NF) process to 30 mgd to meet the City's projected buildout maximum day demands, and installation of the second concentrate disposal deep injection well. Ms. Esposito assists the principal engineer and project manager for this project, using advanced 3D LiDAR technology to capture precise data scans, integrate them with the future work plans, and produce highly accurate 3D representations of the membrane building, filter building, degasifiers, and piping. Ms. Esposito also attends design meetings with subconsultants and City staff, and has assisted the project manager with production of the Preliminary Design Report. The design phase of the project is anticipated to be completed in March 2026.

**Staff Professional/Field Coordinator, Four-Log Virus Treatment Upgrades Study, Design, and Construction, City of Boca Raton, Florida.** This project included the investigation and evaluation of alternatives for optimizing four-log virus treatment relative to disinfection by-product formation, as well as final design and construction of the necessary improvements associated with the selected alternative. The selected alternative included the addition of channel mixers and intra-basin baffles within the lime softening process clearwells, relocation of the sodium hypochlorite and ammonia injection points, and the relocation of the free chlorine, temperature, and pH sample points for four-log virus treatment compliance monitoring. In addition to the disinfection-related upgrades, the design included the addition of filter-to-waste piping and control valves to route the filter effluent to the washwater recovery basin, as well as yard piping modifications to improve operational flexibility and reliability. Ms. Esposito assisted with pay applications, development of construction contract documents, and provided engineering services during construction, including resident project representation. She used advanced 3D LiDAR technology to capture precise data scans, integrate them with the future work plans, and produce highly accurate 3D representations of clearwells and piping. These scans were translated using Revit, ReCap, and BIM 360 for rendering and developing engineering construction drawings. Construction is anticipated to be completed in the fourth quarter of 2026.

**Staff Professional, City of Pompano Beach Water Treatment Plant Emerging Contaminants Upgrades Planning Document, Pompano Beach, Florida.** In March 2023, the USEPA proposed a National Primary Drinking Water Regulation (NPDWR) for certain per- and polyfluoroalkyl substances (PFAS) with an estimated compliance date of December 2026. Under the 2021 Bipartisan Infrastructure Law (BIL), Federal grant funds were made available to drinking water utilities for implementation of water treatment plant upgrades that are necessary to provide compliance with the proposed PFAS regulations. One of the most critical funding document submittals is the Facilities Plan and Planning Document, which provide the definition of the project (i.e., identification of the most cost-effective treatment technology to be utilized) for approval by the DWSRF prior to award of the final design funding. Ms. Esposito assisted in the preparation of documents for the DWSRF Facilities Plan in conformance with applicable DWSRF funding requirements.

**Staff Professional, Glades Road Water Treatment Plant Expansion of the Membrane Pretreatment Pressure Filters, City of Boca Raton, Florida.** The project included the addition of two new 10-foot diameter by 41-foot long, two-cell steel pressure filters similar in design to the existing pressure filters, with all required face piping, fittings, valves, electric valve operators, electrical systems, instrumentation, and controls. Ms. Esposito assisted with the preparation of construction contract documents during this project.

**Staff Professional, Delray Beach Membrane Water Treatment Plant, City of Delray Beach, Florida (September 2025).** This project involved design of the addition of a 25-mgd NF process to the City of Delray Beach's conventional lime softening process to comply with the National Primary Drinking Water Regulation (NPDWR) for per- and poly-fluoroalkyl substances (PFAS) under a progressive design-build (PDB) project delivery. MBC was a subconsultant to the prime project professional (CDM Smith, Inc.) (with Ms. Esposito assisting with the Facilities and pilot testing plans, construction contract documents, and well sampling,) and was tasked with leading the membrane treatment process design, including a 5-micron cartridge filter system, membrane feed pumps, seven 3.67 mgd NF units, and membrane cleaning and permeate flush systems. During the preliminary design phase, MBC was also responsible for individual technical memoranda addressing the potential for blending of the NF permeate with the lime softened water to meet the PFAS NPDWR, evaluation of the raw water supply system relative to NF treatability, raw water quality characterization, as well as NF membrane pilot testing. The findings of the technical memoranda were incorporated into the final design of the facility. Final design was completed in September 2025. Construction is scheduled to begin in early 2027, and is expected to be completed in November 2027. The estimated construction cost is approximately \$250 million.

**Staff Professional, Transfer Pumping Upgrades at the Water Treatment Plant, City of Boca Raton, Florida.** The City's 30 mgd lime softening process operates in parallel with the 40 mgd nanofiltration process. The water from these processes is blended and pumped to on-site finished water storage tanks using two transfer pumping systems, consisting of six pumps total. This project includes replacement of three 150 hp transfer pumps, addition of a seventh transfer pump, process piping modifications, and a comprehensive renovation to the buildings associated with the transfer pump systems. Design of this project was completed in July 2025, and the project is expected to be advertised for bid by the first quarter of 2026. Ms. Esposito assisted the project manager in preparation of construction contract documents during design.

**Kyla Booth**  
Staff Professional



#### Experience Highlights

Designing water treatment plant components, providing construction contract administration, and data analysis.

#### Education

B.S. – Civil Engineering, Florida International University, 2024

OSHA Safety Training Certification

Confined Spaced Training Certification

## Professional Experience

Ms. Kyla Booth serves as a designer and staff professional whose responsibilities include assisting in the process of mechanical design for water treatment facilities, permitting, preparation of engineering documents, drawings, technical specifications, and construction contract administration services. She has been involved in potable water, reclaimed water, water treatment plant improvements, and stormwater related projects.

## Project Experience

**Staff Professional, Water Treatment Plant Emerging Contaminants Design Upgrades, City of Pompano Beach, Florida.** The City has received an SRF planning and design loan under the emerging contaminants funds under Bipartisan Infrastructure Law. MBC assisted the City with preparation and submittal of the planning document in 2024. MBC is currently designing the improvements listed in the planning document. The project consists of the expansion of the City's existing 10 million gallon per day capacity nanofiltration (NF) process to 30 mgd to meet the City's projected buildout maximum day demands, and installation of the second concentrate disposal deep injection well. Ms. Booth assists in the preparation of construction contract documents, attends design meetings with subconsultants and City staff, and has assisted the project manager with production of the Preliminary Design Report. The design phase of the project is anticipated to be completed in March 2026.

**Field Coordinator, Four-Log Virus Treatment Upgrades Study, Design, and Construction, City of Boca Raton, Florida.** This project included the investigation and evaluation of alternatives for optimizing four-log virus treatment relative to disinfection by-product formation, as well as final design and construction of the necessary improvements associated with the selected alternative. The selected alternative included the addition of channel mixers and intra-basin baffles within the lime softening process clearwells, relocation of the sodium hypochlorite and ammonia injection points, and the relocation of the free chlorine, temperature, and pH sample points for four-log virus treatment compliance monitoring. In addition to the disinfection-related upgrades, the design included the addition of filter-to-waste piping and control valves to route the filter effluent to the washwater recovery basin, as well as yard piping modifications to improve operational flexibility and reliability. Ms. Booth has provided engineering services during construction including resident project representation. Construction is anticipated to be completed in the fourth quarter of 2026.

**Staff Professional, Delray Beach Membrane Water Treatment Plant, City of Delray Beach, Florida (September 2025).** This project involved design of the addition of a 25-mgd NF process to the City of Delray Beach's conventional lime softening process to comply with the National Primary Drinking Water Regulation (NPDWR) for per- and poly-fluoroalkyl substances (PFAS) under a progressive design-build (PDB) project delivery. MBC was a subconsultant to the prime project professional (CDM Smith, Inc.) (with Ms. Booth assisting the process engineer with preparation of construction contract documents during design) and was tasked with leading the membrane treatment process design, including a 5-micron cartridge filter system, membrane feed pumps, seven 3.67 mgd NF units, and membrane cleaning and permeate flush systems. During the preliminary design phase, MBC was also responsible for individual technical memoranda addressing the potential for blending of the NF permeate with the lime softened water to meet the PFAS NPDWR, evaluation of the raw water supply system relative to NF treatability, raw water quality characterization, as well as NF membrane pilot testing. The findings of the technical memoranda were incorporated into the final design of the facility. Final design was completed in September 2025. Construction is scheduled to begin in early 2027, and is expected to be completed in November 2027. The estimated construction cost is approximately \$250 million.

**Staff Professional, Transfer Pumping Upgrades at the Water Treatment Plant, City of Boca Raton, Florida.** The City's 30 mgd lime softening process operates in parallel with the 40 mgd nanofiltration process. The water from these processes is blended and pumped to on-site finished water storage tanks using two transfer pumping systems, consisting of six pumps total. This project includes replacement of three 150 hp transfer pumps, addition of a seventh transfer pump, process piping modifications, and a comprehensive renovation to the buildings associated with the transfer pump systems. Design of this project was completed in July 2025, and the project is expected to be advertised for bid by the first quarter of 2026. Ms. Booth assisted the project manager in preparation of construction contract documents during design.

**Field Coordinator, Glades Road Water Treatment Plant, Washwater Recovery Upgrades, City of Boca Raton, Florida.** The Glades Road Water Treatment Plant lime softening process utilizes a washwater recovery basin and return pump system for the treatment (settle) and recycle of filter backwash water and other recyclable treatment process streams. The existing washwater recovery basin was over 35 years old and under this project MBC was authorized to design a new 575,000-gallon octagonal concrete washwater recovery basin with improved process capabilities (supernatant decanting system and a dedicated pump station for a settled sludge handling and washwater return pump system). Ms. Booth provided engineering services during construction including resident project representation.

**Staff Professional, Continuing Nanofiltration Process Optimization Services, City of Boca Raton, Florida.** Since January 2008, MBC has provided continuing process technical services to optimize operation of the City's 40-mgd NF process. MBC's services include quarterly review of the membrane process performance data, plant operating records, wellfield operating records, operating practices, and preparation of quarterly reports on the findings. These reports include recommendations for improvements in operating practices and data collection for optimization of the treatment process and improvements in plant efficiency and reliability. Ms. Booth assists the project manager with the preparation of data analysis and graphics for the quarterly water treatment plant performance reports.

## Ryan Brinson

Designer I



### Experience Highlights

Designing water treatment plant components utilizing Computer-Aided Design software's such as Revit, AutoCAD 2D, and AutoCAD Plant 3D.

### Education

B.A. – Critical and Visual Studies  
Pratt Institute, 2023

## Professional Experience

Mr. Ryan Brinson serves as a designer who assists in the process of mechanical design for water treatment facilities, including development of construction drawings, and other miscellaneous design contributions. He has been involved in water treatment plant improvements related projects.

## Project Experience

**Designer I, Water Treatment Plant Emerging Contaminants Design Upgrades, City of Pompano Beach, Florida.** The City has received an SRF planning and design loan under the emerging contaminants funds under Bipartisan Infrastructure Law. MBC assisted the City with preparation and submittal of the planning document in 2024. MBC is currently designing the improvements listed in the planning document. The project consists of the expansion of the City's existing 10 million gallon per day capacity nanofiltration (NF) process to 30 mgd to meet the City's projected buildout maximum day demands, and installation of the second concentrate disposal deep injection well. Mr. Brinson assists in the preparation of construction drawings, and development of 3D models. He uses advanced 3D LiDAR technology to capture precise data scans, integrating it with the future work plans, and produce highly accurate 3D representations of the membrane building, filter building and degasifiers. These scans are translated using Revit, ReCap, and BIM 360 for rendering and developing engineering construction drawings. The design phase of the project is anticipated to be completed in March 2026.

**Designer I, Four-Log Virus Treatment Upgrades Study, Design, and Construction, City of Boca Raton, Florida.** This project included the investigation and evaluation of alternatives for optimizing four-log virus treatment relative to disinfection by-product formation, as well as final design and construction of the necessary improvements associated with the selected alternative. The selected alternative included the addition of channel mixers and intra-basin baffles within the lime softening process clearwells, relocation of the sodium hypochlorite and ammonia injection points, and the relocation of the free chlorine, temperature, and pH sample points for four-log virus treatment compliance monitoring. In addition to the disinfection-related upgrades, the design included the addition of filter-to-waste piping and control valves to route the filter effluent to the washwater recovery basin, as well as yard piping modifications to improve operational flexibility and reliability. Mr. Brinson used advanced 3D LiDAR technology to capture precise data scans, integrated with the future work plans, and produced highly accurate 3D representations of clearwells and piping. These scans are translated using Revit, ReCap, and BIM 360 for rendering and developing engineering construction drawings. Construction is anticipated to be completed in the fourth quarter of 2026.



# James J. Roberts P.E.

Senior Vice President,  
Florida Operations



## Education

B.E., Civil Engineering; Manhattan College

## Licenses/ Certifications

Professional Engineer: NY

## Memberships

American Water Works Association

NYWEA

## Offices Held

NYS AWWA Past Trustee at Large

NYS AWWA Water Utility Council,  
Past Vice-Chair

Past NYWEA Executive Group

With a distinguished career spanning over 40 years in water resources engineering, Mr. Roberts serves as the Senior Vice President overseeing H2M's strategic initiatives in Florida. Known for his visionary leadership and technical expertise, he plays a pivotal role in driving innovation and excellence across H2M's diverse portfolio throughout the State. Prior to joining H2M, Mr. Roberts served as Deputy Commissioner of the NYC Department of Environmental Protection, where he was responsible for overseeing approximately 1,300 employees, nearly 15,000 miles of water and sewer infrastructure, a capital improvement plan of \$1.5 billion and an annual operating budget of \$185 million, delivering over 1 billion gallons of water a day to 8.5 million New York City residents. Mr. Roberts brings a qualified perspective of what clients are seeking in a consulting experience.

### Selected project experience

- City of West Palm Beach Sludge Drying; West Palm Beach, FL: The City's existing doghouse-style duplex pump system is supplemented by a portable diesel-fueled backup pump. The City procured a replacement duplex pump system for the doghouse-style duplex pumping system consisting of new end suction pumps packaged with a vacuum priming system. The City is currently in the process of replacing the existing end suction pumps with duplex submersibles. As such, the new procured packaged end suction pumps and priming system and controls are currently not expected to be utilized. Evaluated if the procured package duplex pump system could be used to assist with its residuals drying ponds. A trailer powered hydraulically driven submersible pump is currently used to move sludge between ponds to facilitate the drying process.
- City of West Palm Beach Backwash Recovery Basin Pump Station; West Palm Beach, FL: The City owns and operates a municipal water treatment plant (WTP), which includes a backwash recovery clarifier. The clarifier is served by an existing doghouse-style duplex pump system that is currently supplemented by a portable diesel-fueled backup pump due to the duplex system being unable to meet demand. Designed the replacement of the existing pump array with new pumps, to be configured as duplex submersibles. The pumping capacity will be increased from the existing nominal 1,000 gpm per-pump rating to 1,500 gpm 40' TDH rated capacity per pump.
- Croton Water Filtration Plant (CWFP): Created the project transition team that established the operational organizational structure for the City of New York's first ever water filtration plant. At a cost of more than \$3.2 billion, the plant is rated at 290 MG and uses dissolved air floatation technology, full plant automation, and SCADA and CMSS systems. Established staffing, budgetary and training plans for the creation of a greenfield directorate responsible for operations, maintenance and repairs. With a staffing of approximately 60 persons and an operating budget of approximately \$35 million the plant was activated into service in May 2015.
- Executive Chief Engineer, City Tunnel #3 Stage II Manhattan: 8.5 miles of 12 foot diameter deep rock, concrete lined tunnel at elevations up to 500 feet below grade, carrying more than 50 MGD of Catskill/Delaware water to lower Manhattan, it was activated in October 2013. Responsibilities included ensuring regulatory compliance while commissioning four of 10 distribution chambers housing over 20 48" diameter butterfly valves, pump, elevator, HVAC, electrical, plumbing and instrumentation systems. Developed and implemented distribution plans and models to effectively integrate the new tunnel into the existing distribution system without disruption of service.
- Chief of Tunnel Operations and Maintenance, City Tunnel #3 Stage I Manhattan: 13 miles of 24 foot diameter deep rock, concrete lined tunnel activated in 1998 and capable of carrying up to two BGD of flow, this section of tunnel provided critical redundancy and replacement for the northern section of City Tunnel #1, which went into service in 1917. Responsibilities included ensuring regulatory compliance, commissioning all associated mechanical, electrical, pumping, elevator and HVAC systems in 14 distribution chambers including three main control chambers built up to 250 feet below grade in bedrock.
- Director of Capital Construction: QED935: \$35 million capital project that included more than 2.5 miles of 60 inch diameter steel water main and appurtenances, eight, 12 and 20 inch DIP water mains, cathodic protection systems, 15 inch through 48 inch combined sewers both ESVP and RCP and curb, sidewalk and roadway restoration. Included the major reconstruction of Shaft 11A off of City Tunnel No. 2 that included new 72 inch valves, HVAC, electrical, mechanical, plumbing and instrumentation systems.



# Tzufit Boyle P.E., PMP, F.ASCE

Senior Discipline Engineer - Water Resources



Ms. Boyle is a civil engineer with 25 years of experience in surface water design and operations, groundwater contamination, wastewater design, and solid waste design and planning. She is a strong project manager who helps teams meet challenging schedules and balance competing priorities while adjusting to the team's needs to reach a common goal. Ms. Boyle can see project needs on both a task scale, as well as a system-wide broad view. Her expertise includes managing large projects and teams, preparing and reviewing shop drawings, and coordinating office engineering activities including scheduling, pay applications, testing, and change order preparation. She is also experienced in field supervision and has provided engineering services during construction on multiple large-scale projects. Ms. Boyle believes in service to the industry and the community and is involved in leadership at ASCE and Scouting America.

## Selected project experience

### Education

B.S., Civil and Environmental Engineering;  
Carnegie Mellon University

B.S., Engineering and Public Policy;  
Carnegie Mellon University,

### Licenses/ Certifications

Professional Engineer: FL

Project Management Professional (PMP)

### Memberships

American Society of Civil Engineers  
(ASCE), Fellow

ASCE 2024 Convention Local Planning  
Subcommittee Chair

ASCE, Florida Section, Region 5 Governor  
Environmental and Water Resources  
Institute (EWRI), Member

Project Management Institute (PMI)

### Honors/Awards

ASCE Palm Beach Branch Government  
Engineer of the Year (2024)

ASCE Florida Section Government Engineer  
of the Year (2024)

Outstanding Alumni Service Award,  
Carnegie Mellon University (2022)

- Solid Waste Authority of Palm Beach County Design and Construction of MW-1R; West Palm Beach, FL: As Project Manager, responsible for the coordination of consultants and contractors, as well as submissions to regulatory agencies for the new construction of a deep injection monitoring well, MW-1R, at the Palm Beach Renewable Energy Facility (PBREP). Other tasks included coordinating a testing program to establish the viability of the new well and plugging and abandonment of the old existing MW-1 monitoring well.
- Solid Waste Authority of Palm Beach County Design of Replacement Industrial Supply Water (ISW) Wells; West Palm Beach, FL: Project Manager responsible for the coordination of consultants for two separate projects for the replacement of aging ISW wells at the landfill facility at PBREP. Three distinct construction packages were developed for construction of 15 new replacement wells. Coordinated with regulatory agencies and various departments within the Solid Waste Authority.
- South Florida Water Management District (SFWMD) Lake Okeechobee Watershed Restoration Project; Various Locations, FL: As Project Manager, provided project management services to the Office of the Everglades Policy and Restoration. Tasks included the coordination of various disciplines within SFWMD, such as engineering, modeling, ecological, and water supply, to advance planning efforts within the Comprehensive Everglades Restoration Plan (CERP) related to the Lake Okeechobee Watershed, while coordinating with counterparts at the US Army Corps of Engineers (USACE) and other federal, state, and local agencies.
- SFWMD C-44 Pump Station RTA Design Documents; Indiantown, FL: As Project Engineer, provided design services for a new pump station. This work order included the continuation of the project design to Corrected Final/Ready to Advertise (RTA) design documents suitable for solicitation of a construction contractor.
- SFWMD C-44 Stormwater Treatment Area (STA) Engineering During Construction; Indiantown, FL: As Project Engineer, provided engineering services during construction for the following efforts at the C-44 Reservoir/STA site: system discharge structure; STA of approximately 4,000 acres; 1,100-cfs stormwater reservoir pumping station; and remediation of agriculturally impacted soils. Processed contractor submittals and provided engineering support for issues arising during construction.
- SFWMD Interim System Discharge Spillway; Indiantown, FL: As Project Manager, supported the SFWMD with augmenting staff for the construction of the Interim System Discharge Spillway Project for the C-44 Reservoir/STA.
- SFWMD C-44 Communications Tower; Indiantown, FL: As Project Manager, supported the SFWMD with augmenting staff for the construction of the Communications Tower project for the C-44 Reservoir/STA.
- Florida Fish and Wildlife Conservation Commission (FWC) G-111 Structure Repair; Tallahassee, FL: Project Manager for the repair of the G-111 structure, a five-barreled corrugated metal pipe culvert with flashboard control located at the outlet of Lake Jackson. A previous inspection of G-111 found several deficiencies on the structure and surrounding site. Led design efforts to correct these deficiencies and assisted FWC by issuing a request for bid from preselected contractors. Performed a final inspection following project completion.

Next →

# Tzufit Boyle

## P.E., PMP, F.ASCE

Senior Discipline Engineer -  
Water Resources



- U.S. Department of Agriculture (USDA)/Natural Resources Conservation Service (NRCS) 101 Ranch Wetland Reserve Easements Plan of Operations and Design; Okeechobee, FL: As Project Manager, developed and prepared a final Wetland Reserve Plan of Operations (WRPO) that provides for cost-effective restoration enhancement management and maintenance of the 584-acre easement area while maximizing natural wildlife benefits and wetland functions and values. Prepared an engineering design with final engineering plans and specifications.
- USDA/NRCS Russakis Ranch Wetland Reserve Easements Plan of Operations and Design; Okeechobee, FL: As Project Manager, developed and prepared a final WRPO that provides for cost-effective restoration enhancement management and maintenance of the 474-acre easement area while maximizing natural wildlife benefits and wetland functions and values. Prepared an engineering design with final engineering plans and specifications.
- USDA/NRCS Seventy Grove Wetland Reserve Easements Plan of Operations and Design; Highlands County, FL: As Project Manager, developed and prepared a final WRPO that provides for cost-effective restoration enhancement management and maintenance of the 293-acre easement area while maximizing natural wildlife benefits and wetland functions and values. Prepared an engineering design with final engineering plans and specifications.
- SFWMD Everglades Restoration and Capital Projects; Various Locations, FL: Served as Contract Project and Construction Manager to augment SFWMD's full-time staff. Responsibilities included management of projects in design and construction and coordination among different departments and needs within the SFWMD. Duties included review of contractor schedules and safety plans, coordination with contractors regarding plans and specifications, and approval of substitutions. Other duties included development of cost estimates and justifications for recommended contract modifications, negotiation of prices and time extensions, coordination with mechanical and electrical inspectors, and coordination of permitting efforts. Managed several operations and maintenance (O&M) projects involving hurricane hardening of pump stations, canal bank repair, and information technology facilities.
- SFWMD WCA 3A/3B Seepage Management Area, Acceler8 Program; Various Locations, FL. The SFWMD brought eight projects out of its Comprehensive Everglades Restoration Program into Acceler8. These eight projects were further broken down into smaller components. The Water Preserve Areas multi-million-dollar project was further broken into five projects and the 3A/3B SMA project is a 14-mile-long one-half mile-wide strip of land located at the Western edge of Broward County. This land is to be used for seepage management of the Water Conservation Areas to the West and provides flood control to residential areas to the East. Responsibilities included project management, public forum moderation, and preparation of technical memos and basis of design reports (BODRs).
- SFWMD Compartment B STA Everglades Restoration; Various Locations, FL: The SFWMD was designing and building several components of the Comprehensive Everglades Restoration Program. The Compartment B STA was divided into two earthwork components (north and south build-out) and a pump station component (two inflow and one combined outflow). As Staff Engineer, responsibilities included writing the project operation plan and technical memos, providing engineering support, and various project management duties.
- Miami-Dade County Department of Solid Waste Management Disposal Balancing for Internal Landfills; Miami, FL: As Project Engineer, evaluated the use of internal landfills for disposal of different waste streams. Analyzed the data considering both internal and external landfills to show the cost difference between various models.
- Miami-Dade County Department of Solid Waste Management Transfer Station Optimization; Miami, FL: As Project Engineer, evaluated the Transfer Division for efficiency in County-wide waste transfer. The project included analyzing the data, considering the demands of waste by the Resources Recovery Facility to show the waste transfer, and the efficiency with which the loads were transported. A recommendation was made to improve the cycle times between loads and the reporting format for actual weekly results.
- Solid Waste Authority of Palm Beach County West-Central Transfer Station; Royal Palm Beach, FL: The Solid Waste Authority constructed a new transfer station west of Boynton Beach to alleviate loads at other stations and service increased population in the west-central region of Palm Beach County. As Staff Engineer, responsibilities included assistance to the project team with engineering design duties, scheduling of project phases, and overall construction and subcontractor coordination.
- Miami-Dade Water and Sewer Department (MDWSD) High-Level Disinfection at South District Wastewater Treatment Plant; Miami, FL: The Department was required to treat all effluent to a higher standard per EPA and FDEP standards. As Field Engineer, evaluated options for two different treatment technologies: chlorine dioxide and ultraviolet treatment. During sampling events, monitored all equipment and samples for virus parameters.



# Patrick K. Cole P.E., CME, CPWM

Vice President, Deputy Market Director of Water/Wastewater



With 25 years of experience, Mr. Cole is an H2M Vice President and the firm's Deputy Market Director of Water/Wastewater. He leads H2M's efforts in the water and wastewater markets in New Jersey. Mr. Cole's areas of personal practice expertise lie in the optimization of treatment processes, distribution system hydraulic analysis, water quality troubleshooting and construction contract administration. He is a past Chair of the AWWA NJ Section, on the Board of Trustees, and a current contributor to the following AWWA Manual of Practice Workgroups: M31- Distribution System Requirements for Fire Protection; M64- Aeration and Air Stripping.

Additionally, Mr. Cole is a graduate of the Institute in Drinking Water Treatment certification program conducted by UMass Amherst. He typically acts as engineer of record and/or signatory engineer in responsible charge of all phases of project delivery. An example of Mr. Cole's work includes the 2013 Steel Tank Institute's Tank of the Year, a 1.5MG hydropillar delivered in a design-build project format.

## Selected project experience

### Water

- Aquarion Water Company Blachely Pump Station and North Street Wells Scanning and As-Built Drawings; Shelton, CT: Deployed experienced field engineers, using Matterport Professional Capture 3D technology, to create three-dimensional records drawings of two existing remotely-operated stations, owned by Aquarion Water Company. (Ongoing)
- City of West Palm Beach Surface Water Treatment Term Contract; West Palm Beach, FL: Assisting in as-needed surface water treatment projects for the City of West Palm Beach. To date, designed the replacement of an existing pump array with new pumps, to be configured as duplex submersibles. The pumping capacity will be increased from the existing nominal 1,000 gpm per-pump rating to 1,500 gpm 40' TDH rated capacity per pump. (Ongoing)
- Township of Parsippany-Troy Hills Replacement of Well No. 20; Parsippany, NJ: Principal-in-Charge overseeing the team designing, and permitting a replacement well and water treatment plant of matching capacity to the existing Well 20, with effluent treated to the standards of the NJ State and Federal Safe Drinking Water Acts. (Ongoing/2025)
- Southeast Monmouth Municipal Utilities Authority (SMMUA) Northwest Wall Infrastructure Improvements; Wall, NJ: Principal-in-Charge for the design of a new pressure zone to support the SMMUA's surface water treatment plant. The project includes approximately 1,600 feet of new transmission main; installation of four pressure reducing valves, one check valve, and one flow meter vault throughout the Wall system; rehabilitating the existing Route 34 well facility's electrical gear, replacement of booster pumps and motors; and construction of a two million gallon ground storage tank and adjacent three-pump booster station. (Ongoing/2025)
- Township of Wall General Consultation; Wall, NJ: Principal-in-Charge for as-needed support to the Township of Wall Zoning Board of Adjustment, as well as the Township's water resources and sewer projects. (Ongoing)
- North Jersey District Water Supply Commission (NJDWSC) Lagoon Decant Tower Discharge Design-Build; Wanaque, NJ: As a subconsultant to Stone Hill Construction, served as Project Director for the design and construction of a new water treatment facility to house electrocoagulation process (EC), dissolved air flotation (DAF), and activated filter media (AFM) filtration systems, as well as a new decant tower. The NJDWSC has a 10 surface-acre Lagoon which it uses for Water Treatment Residual (WTR) storage. The Lagoon is the regulated unit for a New Jersey Pollutant Discharge Elimination System (NJPDES) Permit for Discharge to Surface Water (DSW). The current decant discharge from the Lagoon is discharged via a Decant Tower at the southern end of the Lagoon to the Wanaque Reservoir. Additionally, an overflow structure discharges to a tributary of the Post Brook. Part of the DSW permit condition requires the decant discharge from the Lagoon to comply with a Whole Effluent Toxicity (WET) test for Ceriodaphnia by March 2015. Regulated testing and special testing by WET methodologies currently do not meet the future WET NJPDES Permit level of 55% survival or reproduction, whichever is lower. To meet WET requirements, a pilot study was initiated to evaluate several technologies to identify the best process option. (2024)

Next →

### Education

M.S., Civil/Environmental Engineering;  
Rutgers University

B.S., Mechanical Engineering; University  
of Delaware

Institute in Drinking Water Treatment;  
UMass Amherst

### Licenses/Certifications

Professional Engineer: NJ, NY

Certified Municipal Engineer: NJ

Certified Public Works Manager

### Offices Held

AWWA-NJ, Section Chair, 2022-2023

AWWA-NJ, Member, Board of Trustees,  
2018-Present

AWWA National, Distribution and Plant

Operations Division, Trustee 2012-2015

AWWA Manual of Practice M64, Co-Author

### Memberships

American Water Works Association

Water Environment Federation

National Fire Protection Association

### Honors

AWWA NJ Fresh Ideas Award, 2007

Next Generation Award, 2009

Steel Tank Institute: 2013 Tank of the Year  
(Signatory Engineer)

# Patrick K. Cole

P.E., CME, CPWM

Vice President, Deputy Market  
Director of Water/Wastewater



- Sisters of Charity Water Infrastructure Improvements; Morris, NJ: Practice Leader to support the Sisters of Charity of St. Elizabeth in retiring their independent/private water status, and assume the status of retail customers to the local public water franchise-holder, New Jersey American Water. Led the development of a New Jersey American Water service connection application, NJDEP coordination, and outreach to municipal fire sub-code officials. (2024)
- City of Pompano Beach Water Treatment Plant Emerging Contaminants Upgrades Planning Document; Pompano Beach, FL: As a subconsultant to McCafferty Brinson Consulting, conducted pilot of ion exchange and GAC media to determine the best media option for the removal of PFAS at the City of Pompano Beach Water Treatment Plant (WTP). The project entailed a comparative review of treatment technologies, potentially to be used in modifications to an existing 50 MGD potable WTP. The City's WTP, utilizing a combination of nanofiltration (NF) and conventional lime softening (LS), currently produces water in compliance with Florida and USEPA regulations for drinking water. However, PFAS (per- and polyfluoroalkyl substances) have been detected in the plant's process water stream. The City required an evaluation to identify optimum treatment technologies, and further identify the preferred placement of such technologies within the existing plant's treatment train. (2024)
- Brick Township Municipal Utilities Authority (BTMUA) GAC Improvements at William Miller Jr. Water Treatment Plant; Brick, NJ: Project Director responsible for the design, permitting, and bidding for new GAC vessels to treat PFOA at the William Miller Treatment Plant in Brick Township, NJ. The Metedeconk River, BTMUA's source water, exhibited the highest concentration of PFOA of any raw water source tested within the state in 2009 by the New Jersey Department of Environmental Protection (NJDEP). (2024)
- Borough of Ringwood Public Water System Operational Support and Regulatory Compliance Coordination; Ringwood, NJ: Practice Leader responsible for review of the Borough's existing regulatory compliance communications and outstanding action items, review of daily procedures and analytical/reporting structures for water quality and pumpage, and regular interaction with the licensed operator of record regarding operational decisions. (2024)
- Borough of Ringwood General Water Support; Ringwood, NJ: Principal-in-Charge responsible for overseeing the update of the Borough's existing geographic information system (GIS) maps. (2024)
- Borough of Butler Reconfiguration of the Butler Water Treatment Plant; Butler, NJ: Principal-in-Charge responsible for leading design, permitting, and bidding services for the expansion and modernization of the Butler Water Treatment Plant. (2024)
- Borough of Chatham General Consultation; Chatham, NJ: Principal-in-Charge for as-needed support for the Borough's water resources and sewer projects. (2024)
- Borough of Highlands General Consultation; Highlands, NJ: Principal-in-Charge for as-needed support for the Borough's water resources, sewer, and special projects. (2024)
- Veolia Well Station No. 56 and 82 PFAS Upgrades Design-Build; Rockland County, NY: Project Director for the design-build delivery of upgrades to two well stations – Wells No. 56 and 82, known respectively as the Willow Tree and Eckerson Stations – that had begun to exhibit contamination by PFAS substances. Work included planning, permitting, design, construction observation, start-up, testing, and commissioning. (2024)
- Monroe Township Utility Department (MTUD) Well No. 25 Iron Removal Plant Design; Monroe, NJ: Principal-in-Charge responsible for executive oversight of the design and permitting of a new groundwater public supply well facility, Well No. 25, North of Matchaponix Avenue, in Spotswood Manor. MTUD constructed Well No. 25, which was originally configured as a test well, and was converted into a potable production well. The site and treatment system were designed to include provisions for the installation of a second well. (2024)
- New Jersey Department of Environmental Protection (NJDEP) Trenton Water Works (TWW) Technical, Managerial, and Financial Capacity Report; Trenton, NJ: Principal-in-Charge responsible for executive oversight of a comprehensive technical, managerial, and financial (TMF) capacity report for the Trenton Water Works (TWW) and the City of Trenton. Regulatory actions taken by the NJDEP against TWW and the City of Trenton including notices of noncompliance, notices of violation, and financial forbearance on the City's outstanding Infrastructure Bank loans have led to the issuance of a Unilateral Administrative Order (UAO), granting the NJDEP operational oversight of the TWW treatment and distribution systems until all issues are corrected. As part of the UAO, NJDEP solicited bids for assistance in various aspects of their corrective actions; one such portion of work was the preparation of a TMF report to document the condition of the TWW system and its management, ultimately informing its ability to maintain operation in both the near and future timeframes. (2024)
- New Jersey American Water (NJAW) Ranney Station Well No.1A Emergency Replacement; Carneys Point, NJ: Principal-in-Charge responsible for executive oversight of the team that prepared design documents, permitted, and provided construction support for the emergency replacement of the failing Well No. 1A. (2023)

# Patrick K. Cole

P.E., CME, CPWM

Vice President, Deputy Market  
Director of Water/Wastewater

- Southeast Morris County Municipal Utilities Authority Electrical Studies, Safety Programs, Training, and Related Matters; Cedar Knolls, NJ: Project Manager responsible for the oversight of field data collection, one-line diagram/short circuit study, coordination study, arc flash analysis, engineer's report, arc flash labeling, and training program. (2016)
- United Water New Jersey Northvale Raw Water Diversion Station; Northvale, NJ: Project Manager for the environmental response, sampling, and reporting in response to a 2014 release from a circa 1960s pole-mounted transformer near United Water's Danny Lane, Northvale, NJ raw water diversion station. (2016)
- New Jersey American Water (NJAW) Mountain Station Rehabilitation; Bound Brook, NJ: Project Manager for the design, permitting, bidding, and construction administration and observation for upgrades to the Mountain Station, an existing groundwater source in the Raritan Service Area. (2016)
- Monroe Township Utility Department (MTUD) Well No. 20 Treatment Process Evaluation; Monroe, NJ: Project Manager responsible for a water chemistry evaluation and treatment process evaluation for the process water associated with the MTUD's Well No. 20. The treatment facility had begun to exhibit performance issues, such as shortened filter run times and contaminant breakthrough, when treating raw water from Well No. 20. (2015)





# Daniel J. Aiello P.E.

Associate, Department Manager - Structural Engineering



Mr. Aiello is a structural engineer with more than 10 years of experience in the assessment and design of multi-story residential/commercial buildings, schools, storage facilities, barge bulkheads, and more. He serves as H2M's Department Manager of Structural Engineering. Mr. Aiello has effectively implemented his experience with steel, concrete, masonry, wood, and cold-formed design in all his projects. He applies his background in geotechnical engineering to design various foundation systems and retaining structures.

## Selected project experience

### Education

#### Education

M. Eng., Structural Engineering;  
Syracuse University

B.A., Civil Engineering;  
Syracuse University

#### Licenses/ Certifications

Professional Engineer: NY, NJ, CT, FL, MD,  
PA

- SUNY Stony Brook University New Storage Warehouse Building; Stony Brook, NY: Structural design of a new pre-engineered warehouse to store dry good and miscellaneous property of the University. The design includes foundations and footings, slab, and wall and roof framing. (2024)
- Paterson Public School District John F. Kennedy High School Gymnasium HVAC System Replacement; Paterson, NJ: Provided structural engineering services associated with the replacement of HVAC systems in the gymnasium. Evaluated the structural component of the existing walls separating the gymnasium and lower roofs at the proposed penetrations for the duct openings. (2024)
- New York Institute of Technology Salt Shed and Site Improvements; Old Westbury, NY: Provided structural engineering services for a new 60-ton capacity salt shed and fuel tank dispensary with new canopy. Coordinated design loading criteria and layout with pre-engineered structure fabricator; designed foundations, floor slab, and push walls; and prepared construction documents for the purpose of NCDOSH and Village of Brookville permitting and bidding documents. (2024)
- Harrison Central School District Bond Projects; Harrison, NY: Structural engineering services for various improvements projects at the District. (2024)
- Longwood Central School District Bond Projects; Middle Island, NY: Structural engineering services for various improvements projects at the District. (2024)
- Harrison Central School District Parsons Memorial Elementary School Interior Renovations; Harrison, NY: Prepared plans and specifications for structural supports for HVAC equipment replacements. (2023)
- Irvington Union Free School District Facilities Storage Building; Irvington, NY: Designed the structure of a new facilities storage building at Irvington High School (2022)
- Farmingdale Union Free School District Howitt Middle School Aquatic Center Addition; Farmingdale, NY: Performed structural evaluations to ensure a newly constructed pool was designed according to specification and was structurally sound. Evaluations included testing the pool's ability to hold water, testing the concrete base of the pool, and verifying that installed steel reinforcements comply with the American Society for Testing and Materials standards. (2021)
- Harrison Central School District Harrison Avenue Elementary School Interior Renovations; Harrison, NY: Prepared plans and specifications for a new elevator addition and interior stair lift at Harrison Avenue Elementary School. (2021)
- Hastings-on-Hudson Union Free School District Farragut Middle and High School Upgrades; Hastings-on-Hudson, NY: Provided structural engineering design services in connection with interior and exterior alterations throughout the Middle School and High School. (2021)
- Hastings-on-Hudson Union Free School District Hillside Elementary School Addition and Renovations; Hastings-on-Hudson, NY: Provided structural engineering design services in connection with miscellaneous renovation work and a roughly 12,500 square foot addition to Hillside Elementary School. (2021)

Next →

# Daniel J. Aiello

PE.

Associate, Department Manager -  
Structural Engineering

- Hastings-on-Hudson Union Free School District Farragut Middle School Auditorium and High School Music Suite; Hastings-on-Hudson, NY: Provided structural engineering design services for the renovation of two music classrooms and an auditorium and stage alteration. (2021)
- Irvington Union Free School District Concession Stand Building; Irvington, NY: Designed the structure of a new concession stand at Irvington High School (2021)
- New York Institute of Technology Campus Commons Building; Old Westbury, NY: Provided structural engineering design services for a proposed 88,650 square foot building to serve as an anchor for future development of facilities within the NYIT campus master plan. (2020)
- Syosset Central School District South Grove Elementary School Gym Structural Repairs; Syosset, NY: Provided structural engineering services for reconstruction of the gym piers at the movable wall partition. In addition, the existing cracks of the CMU walls of the gym were repaired and expansion joints were installed. (2020)
- Second Development Services BCPS Charter School; Brooklyn, NY: Structural Project Manager for the design of a 10-story school/ambulance bay building with a 20-foot basement. Support of excavation was also provided by means of soldier beam and lagging along with laterally supported underpinning. Managed staff engineers during the design process and coordinated the structural scope with the architects and mechanical engineers. (2015)
- BBS Architects Multiple Education Projects; Long Island, NY: Structural Project Manager for the design of six school add-ons and buildings; as well as renovations to multiple schools. These buildings were often comprised of steel frame and bar joist construction. A notable project completed was the design of a new 12,000 square foot building at Long Island University. Managed staff engineers during the design of these structures as well as accompanying the lead architects at superintendent meetings. (2013 to 2015)

## Energy

- Ørsted New York O&M Hub Building Renovation; East Setauket, NY: Supported the design of all structural elements of a building design for the alteration of an existing 60,000 square foot warehouse with an Operational and Control Data hub and office space. The design incorporates sustainable elements where possible to attain LEED certification. (2024)
- National Grid Vaulted Sidewalk Inspection and Repair; Queens, NY: Designed and managed the rehabilitation of the vaulted portion of the existing sidewalk located in front of the payment center structure in Jamaica, Queens. The vaulted portion of the sidewalk extends approximately 50 feet along the front facade of the building and six feet away from the front of the building into the sidewalk. (2024)
- National Grid Greenpoint Campus Demolition; Brooklyn, NY: Developed existing plans for a structure to be demolished at the National Grid campus in Brooklyn. Visited site and assessed whether the building could be safely demolished if existing shoring were to be removed. (2023)

## Municipal

- Westchester County Daniel P. Thomas Material Recovery Facility Tipping Floor Slab Repair; Yonkers, NY: Engineering services to address structural deficiencies in the tipping floor slab located at the Westchester County Daniel P. Thomas Material Recovery Facility. (2024)
- Oceanside Public Library Addition and Renovation; Oceanside NY: Led a team of structural engineers for the design of a two-story steel framed building with a basement subject to groundwater uplift forces. One of the stand-out structural elements in this design was a large cantilevered portion of the building. Managed a team of structural engineers during the design process and coordinated the structural scope with the architects and mechanical engineers. (2023)
- Westchester County Daniel P. Thomas Material Recovery Facility Roof, HVAC, and Electrical Upgrades; Yonkers, NY: Structural engineering services in connection with the preparation of plans and specifications for the replacement of the existing roofing system and HVAC and electrical upgrades at a series of four buildings at the Daniel P. Thomas Material Recovery Facility. (2023)
- Town of Brookhaven Archived Records Center; North Bellport, NY: Provided structural engineering services for the development of construction documents for a renovated and expanded regional Archives data center. The facility will meet NYS Archival Standards, including temperature and humidity controls, and serve as a central scanning repository. (2023)
- Mastic Moriches Shirley Community Library Moriches Annex; Moriches, NY: Led a team of structural engineers for the design of a one-story wood and steel-framed building with a raised floor system and shallow foundation. Managed a team of structural engineers during the design process and coordinated the structural scope with the architects and mechanical engineers. (2022)

# Daniel J. Aiello

## PE.

Associate, Department Manager -  
Structural Engineering

- United States Postal Service (USPS) Greenpoint Post Office Station Window Replacement; Brooklyn, NY: Provided structural engineering design services in connection with the replacement of multiple damaged windows at the station. (2020)

### Public Safety

- Manhasset-Lakeville Fire District New Ambulance Building; Great Neck, NY: Structural design services for a new 10,000 square foot, two-story, four-bay ambulance building, including kitchen, lounge area, bunk rooms, meeting room, and offices. The District owns the existing site and has two existing buildings located on the rear of the site that H2M designed 10+ years ago. (2024)
- Copiague Fire District New Storage Building; Copiague, NY: Preparation of structural plans and specifications for a proposed storage building for the District. Design for this pre-engineered structure includes foundations, slab on grade, and interior mezzanine. (2024)
- Friendship Engine and Hose Co. New Fire Station; Merrick, NY: Responsible for the structural design of a new fire station to be built in Merrick, NY (2024)
- Massapequa Fire District New Combined Fire/EMS Station; Massapequa Park, NY: Structural design for a new 21,600 square foot station containing seven bays, including one drive-through bay, that houses both a fire company and a rescue company; integrated hands-on training; transition zones between bays and the administration sides; company offices; fitness facilities; training classrooms; and public meeting spaces. (2023)
- North Massapequa Fire District Headquarters Additions and Alterations; North Massapequa, NY: Prepared structural plans and specifications for a two-story addition composed of an apparatus bay, storage mezzanine, and storage space above the new apparatus bay. (2023)
- Centereach Fire District Station 2 Addition and Alterations; Lake Grove, NY: Prepared structural drawings and specifications for the renovation and 9,100 square foot addition to Station 2 of the Centereach Fire District. (2019)

### Water & Wastewater

- Greenlawn Water District Wellhead Treatment at Plant No. 10 and 15; Greenlawn, NY: Prepared structural plans and specifications for the design and construction of a new water treatment building at the site of the District's Well Nos. 10 and 15. This new treatment system secures the District's compliance with the recently issued Maximum Contaminant Level (MCL) for perfluorinated compounds as well as low levels of VOCs. (2024)
- South Huntington Water District AOP Treatment at Plant No. 8; Huntington Station, NY: Provided structural engineering services in connection with the design of a new wellhead treatment system for 1,4-Dioxane removal at the District's Plant No. 8. The project was broken into two distinct construction phases – interim and permanent construction. (2024)
- Village of Nyack Water Department Emerging Contaminant Removal at Nyack Water Plant; Nyack, NY: Provided structural plans and specifications in connection with the construction of a new treatment building and clearwell for perfluorinated compounds on the northwest side of the existing Nyack Water Plant. (2024)
- Ocean County Utilities Authority (OCUA) Operations and Maintenance Building and Seaside Park Pump Station CPS-3 Generator Replacements; Brick and Seaside Park, NJ: Designed structural supports to accommodate two replacement generators at OCUA facilities. (2023)
- Town of Hempstead Department of Water AOP Treatment at Levittown Well Nos. 7A and 8A; Levittown, NY: Provided structural plans and specifications for the design and construction of a new building to house the AOP and GAC equipment needed to treat 1,4-Dioxane. (2023)
- Plainview Water District Emerging Contaminant Treatment at Plant No. 4; Plainview, NY: Provided structural engineering services to design a new nitrate/perchlorate, AOP, and GAC treatment facility at the District's Plant No. 4 site. (2023)
- Bethpage Water District Well House No. 7 and 8 Roof Replacements and Improvements; Bethpage, NY: Provided structural engineering services for renovations and roof replacement at Well House No. 7 and 8. The existing flat roofing system was replaced with a new gable end pitched roofing system consisting of metal framing and asphalt shingles. The project also involved replacing the existing windows, doors, acoustical ceiling tiles/lighting, and interior painting. (2023)
- Town of Riverhead Sewer District Biosolids Detailed Design; Riverhead, NY: Provided structural engineering services to prepare detailed plans and specifications to add a Class A biosolids process to the existing Town of Riverhead Water Resource Recovery Facility. (2023)





# Gregory M. Cellamare P.E.

Assistant Vice President, Boca Raton Office Director



## Education

M.S., Environmental Engineering;  
Manhattan College

B.S., Earth Science; Pennsylvania State  
University

## Licenses/Certifications

Professional Engineer: FL, NY

OSHA 40-hour HAZWOPER & 8-hour  
refresher

OSHA Confined Space Entry

NJDEP Underground Storage Tank  
Certification; Closure No. 22376

OSHA 30- & 10-hour Construction Safety  
& Health

OSHA DOT Hazmat General & Security  
Awareness Certification

NYS DOB Four Hour Supported Scaffold  
Training

New Jersey Department of Environmental  
Protection Industrial Site Recovery Act  
(ISRA) Training

NYS Department of Health (NYSDOH) Soil  
Vapor Intrusion Training

NYSDOH Regulatory Training in  
Underground Storage Tanks

ESI Groundwater Flow & Contaminant  
Transport Modeling Course, Washington  
D.C.

Mr. Cellamare has over 25 years of experience in environmental engineering and is the Office Director for the Boca Raton, Florida office. His focus is growing the office and providing the necessary vision, planning, project execution, and technical direction for success in the Florida region. His responsibilities include collaborating with discipline, office, and market directors across H2M, to further develop H2M's presence in the local community, to lead and develop a strong discipline team, and to evaluate opportunities in the Florida region and prepare proposals.

Environmental engineering experience includes Engineer of Record (PE) responsibilities for several vapor barrier/sub-slab depressurization system designs, and multiple construction dewatering designs. He has particularly extensive experience implementing innovative remedial technologies to facilitate mitigation and remediation. Throughout his years in the industry, he has become extremely well versed in laws and regulations from various states and the Federal government. His experience also includes managing multi-year term contracts for public agencies. Mr. Cellamare's specific due diligence experience includes the completion of numerous soil, soil-vapor, and groundwater contamination investigations for sites governed by various states' laws, the USEPA, Federal Superfund, and RCRA. These investigations include delineation and remediation of soil and groundwater impacted by petroleum, chlorinated solvents, and metals. He has supervised underground storage tank removal/closure projects, and the installation, operation and maintenance of various types of remedial systems. He has provided environmental construction management services for numerous "mega-projects." Construction management experience includes management of spoils classification and disposal, noise and air quality impacts, groundwater treatment and disposal, permitting, and erosion and sediment control.

## Selected project experience

- City of West Palm Beach Spill Prevention, Control, and Countermeasures (SPCC) Plan & Chemical Bulk Storage (CBS) Program Review; West Palm Beach, FL: Preparing an SPCC Plan and performing a review of the CBS program for the City's WTP. The SPCC will include information on prior spill events; a prediction of direction and flow for potential spill events; a description of existing storage systems and spill prevention equipment; a review of site drainage and facility transfer operations; a review of inspections and records, an assessment of the facilities security systems; and training staff on spill prevention procedures. The CBS program review will inspect all chemical bulk storage areas, including indoor and outdoor storage tanks, drums, and containers. The inspection will involve verifying the conditions of containment areas, spill control measures, secondary containment, and venting; evaluating labeling, signage, and hazard communication compliance; assessing chemical segregation practices to prevent incompatible chemical storage; an exterior visual assessment of the physical condition of storage tanks, piping, valves, and connections for signs of wear, corrosion, or leakage; and a review the facility's tank testing records and any recent maintenance or inspections. A gap analysis will be provided to the City for review and implementation.
- New York City Department of Environmental Protection (NYCDEP) Bureau of Water and Sewer Operations (BWSO) Environmental Health & Safety (EHS) Management Services; New York, NY: Provided EHS management services, including engineering and environmental consulting services for the NYCDEP BWSO. Work included a wide range of assignments related to EHS regulatory compliance; EHS health and safety program support; spill investigation and remediation support; program development and audits; and incident investigation support.
- PSEG Long Island: Serving as Project Manager for an on-call environmental services term contract. The three most recent projects completed under this contract involved pre-development activities for proposed new or renovated substations. Activities completed included the design and implementation of remediation and closure plans for seven underground injection control (UIC) wells and up to eight registered and unregistered underground storage tanks. In addition, designed and implemented several in-situ waste characterization plans, which were intended to ensure anticipated excavation areas and depths of excavations were adequately represented as per facility disposal sampling protocol, while effectively optimizing the number of borings to be installed and samples to be collected. The approach also intended to provide a simplistic approach to assigning excavated soils a classification (e.g., hazardous, non-hazardous, etc.) and facility destination as the excavation progresses real time. In addition, his design reduced environmental impacts (runoff, odors, dust, etc.) that are common with stockpiling.

Next →

# Gregory M. Cellamare

P.E.

Assistant Vice President,  
Boca Raton Office Director



- National Grid, Brooklyn Navy Yard: As Environmental Manager for the construction of a 25MM natural gas heater and gate station, responsible for environmental oversight of pre-construction activities and construction monitoring services. The project was within a NYSDEC Voluntary Cleanup Site with an active Site Management Plan and was also part of a larger parcel included on the National Register of Historic Places. Pre-construction responsibilities included the completion of a Phase II environmental investigation including a geophysical survey, as well as installation and sampling of soil borings and monitoring wells. Pre-construction services also included management for demolition of a substation which encompassed PCB sampling and transformer dielectric fluid sampling, transformer and hazardous material disposal, and paint sampling for PCBs and heavy metals. Responsible for design and permitting of a dewatering system including the determination of aquifer parameters using in-situ slug testing and data analysis, removal of total suspended solids by settling tank and bag filtration design, and a sewer hydraulic capacity analysis and dewatering permit application for discharge to the New York City combined sewer. Managed pre-construction building surveys, including internal and external structural surveys of two historic buildings adjacent to the project site, and a baseline optical survey to document both historic buildings' coordinates in the x, y, and z planes. Responsibilities for construction monitoring activities included performance of a CAMP to measure volatile organic compounds and particulates; 24/7 vibration monitoring services and optical building surveys; preparation of daily field reports; management of excavation and disposal of 4,000 tons of contaminated soil; management of the groundwater treatment system and discharge of 650,000 gallons of water; and natural gas pipeline hydrotest pipe drying QA/QC. Following completion of the project, a Final Closure Report was prepared that provided documentation and analysis of both the pre-construction and construction monitoring activities.
- New York City Housing Authority: Performed engineering analysis of NYCHA petroleum remediation systems. Responsible for analyzing performance of groundwater drawdown and mop/skimmer remediation systems at 20+ housing complexes with active (open) NYSDEC petroleum spills. The goal was to provide recommendations to ensure optimal system performance and help expedite spill "closure." The analysis included developing a full understanding of each specific remediation system and site characteristics. This was accomplished through analyzing current and historical groundwater and product thickness from the monitoring well and recovery well networks and by analyzing free product thickness trends and remedial system data. Recommendations were provided in Quarterly Progress Reports reviewed and approved by the NYSDEC.
- Confidential Utility Company: Tasked with facilitating closure of open NYSDEC spills from utility vaults throughout New York City, and designing and implementing the utility vault sampling program. The spills were due to pipes leaking PCB-laden dielectric fluid onto the surface of the concrete vaults. The sampling was designed to meet the protocol published by the USEPA SOP for Sampling Porous Surfaces for PCBs. Developed a health and safety plan (eHASP) to be following during the sampling events. The eHASP was developed by completing a hazard assessment and confined space analysis, and by determining potential issues with ammonia, hydrogen sulfide, methane, and carbon dioxide, as well as exposure to PCBs. The client reviewed and approved both the sampling design plan and eHASP. Vault sampling has been successfully completed with no safety issues and resulted in the closure of open spills.
- Criterion Development Group: Project Manager for the investigation and remediation of a planned 657,332 square foot 80/20 inclusionary 711-unit housing development. The site was enrolled under the NYSDEC Brownfield Cleanup Program. Responsible for preparing required documents for NYSDEC approval, including the Citizen Participation Plan, Remedial Investigation Work Plan, Interim Remedial Measure Work Plan, Construction Completion Report, Remedial Investigation Report, Remedial Action Work Plan, and Final Engineering Report.
- Port Authority of New York & New Jersey, LaGuardia Airport Central Terminal Building Replacement: As Environmental Deputy Project Manager, responsibilities included the design of a spoils classification program for the removal of approximately 400K CY of contaminated soil. Prepared request for proposal for distribution to potential subcontractors, and securing all required NYCDEP and NYSDEC permits for groundwater removal and discharge to Flushing Bay.
- Metropolitan Transit Authority Capital Construction: Senior Environmental Field Manager for construction of the Second Avenue Subway in Manhattan. Enforced contract specifications related to all aspects of federal, state, and local environmental regulations, including noise, air quality, groundwater treatment, soil disposal, historical spill closure, temporary controls, and rock blasting. Provided review and approval of all environmental plans and weekly/daily submittals, and supervised multiple field environmental inspectors. Coordinated with the NYSDEC, Consolidated Edison, MTA, and the general contractor for the investigation and removal of soils and groundwater impacted with MGP wastes associated with the East 99th Street Gas Works, within the area of construction for the 96th Street Station.
- New York City Office of Environmental Remediation: Served as Project Manager for a term contract to manage the investigation and remediation of brownfield sites.
- New York Power Authority: As part of a natural gas conversion project, provided tank removal/closure design for UST at the Metropolitan Hospital Center in Manhattan. Project management responsibilities included site assessment design, review and approval of a groundwater treatment system, waste characterization, all regulatory coordination and reporting, and off-site transport and disposal of contaminated soil. Metropolitan Hospital Center lies within a NYS Voluntary Cleanup site (former manufactured gas plant) and required coordination with the responsible party and the NYSDEC.



# Kenneth R. Gehringer

AIA, NCARB, CDT, CCCA, NYSCEO

H 2

M

Assistant Vice President, Studio Director

Mr. Gehringer is an award-winning architect with 35 years of diverse experience in New York, Florida, New Jersey, Connecticut, and South Carolina. His expertise includes public works projects, including water and wastewater treatment facilities and municipal offices; educational projects; and private real estate developments. As an Assistant Vice President and Studio Director at H2M, Mr. Gehringer is responsible for overseeing 14 experienced architectural staff, reviewing design and construction documents, and performing client and financial management. As a New York State Code Enforcement Official, he is skilled in analyzing compliance with various building codes.

## Selected project experience

- Castle Lanterra Vue at Belleair Phase II; Clearwater, FL: Management of an expansion of 169 new units between two sites. Site 'A', known as Site North, is 1.2 acres. Site 'B', known as Site South, is 2.0 acres. Site North will house Building North at 64,714 square feet and Site South will house Building South at 111,177 square feet. Both buildings contain an easement for an aging water main that belongs to the City of St. Petersburg. The two sites were also zoned by U.S.19's form-based code. This added a level of unusual complexity. The code required both buildings to be podium design and at two different specific heights.
- Castle Lanterra The Quadrangle Parcel 17; Orlando, FL: Management for the addition of a multi-family residential apartment complex to the Orlando Quadrangle Business Park. H2M conducted a feasibility study of the site in collaboration with the client's civil engineer to see where the multi-family building could be located on the site. We explored how to maximize the quantity of units while also providing parking below the residential units. Because the developer is updating the Quadrangle, zoning rules have been under review to be re-vamped. The project is currently in the early stages of schematic design development.
- Management of facility projects in South Florida. Construction types include masonry, wood frame, and tilt-up construction, many in High Velocity Hurricane Zones (HVHZ), costal and waterfront. Some of his experience includes:
  - Three five-story ocean front condominiums, Ft. Pierce, FL
  - Commercial buildings – new construction and renovations in Delray Beach, FL
  - Professional and health care buildings and ensuing tenant improvements including an MRI suite, Boynton Beach, Delray Beach, and Boca Raton, FL
  - Model home programs for local and national builders, including Lennar, Transeastern Homes, Toll Brothers, Centex, WCI Communities, KB Homes, K. Hovnanian Homes, etc. throughout Miami-Dade, Broward, Palm Beach, Martin, St. Lucie, and Collier Counties
  - Two private school additions in Palm Beach County, FL
- Liberty Utilities Wellhead Treatment at Indian Hills and Arbor Hills; Lewisboro, NY: Responsible for architectural services for the design and construction of a new treatment building, including radium, uranium, PFAS, and iron treatment systems for the Indian Hills/Arbor Hills water systems located in the Goldens Bridge area of Lewisboro, NY.
- Manhasset-Lakeville Water District Advanced Oxidation Process (AOP) and Granular Activated Carbon (GAC) Treatment at Searingtown Road Plant; Manhasset, NY: Led architectural services for the preparation of plans and specifications associated with the construction of AOP and GAC treatment systems at the Searingtown Road Plant.
- Manhasset-Lakeville Water District PFAS Treatment at Campbell Well No. 1; Great Neck, NY: Led architectural services for the preparation of plans and specifications for the construction of a new permanent GAC facility located at the Campbell Station to treat effluent from Campbell Well No. 1.
- Village of Nyack Water Department Emerging Contaminant Removal at Nyack Water Treatment Plant; Nyack, NY: Responsible for architectural design of the construction of a new treatment building and clearwall on the site of the existing Nyack Water Treatment Plant.

Next →

## Education

B.S., Architectural Technology;  
New York Institute of Technology

## Licenses/ Certifications

Registered Architect: FL, NY, NJ, CT

National Council of Architectural Registration  
Boards (NCARB)

Certified Construction Contract Administrator,  
CSI

Construction Documents Technologist, CSI

New York State Code Enforcement Official

NYS/DOL Asbestos Project Designer

OSHA 10-Hour Construction Health and Safety

CAL/OES Safety Assessment Certification

PM Bootcamp, PSMJ Resources

## Offices Held

AIA Long Island, President 2024 - 2025,  
President-Elect 2022 - 2023, Treasurer 2020 -  
2021, Secretary 2018 - 2019, Board of Directors  
2017

CSI Long Island, President 2023 - 2024,  
Vice President 2014 - 2023, President 2007  
- 2010, Planning Chair 2009 - 2010, Program  
Chair 2005 - Present, Education Chair 2004 -  
Present, Board of Directors 2004 - 2005

CSI Northeast Region, Board of Directors 2021  
- present, President 2011 - 2013, Conference  
Committee 2013, Vice President 2010 - 2011,  
Board of Directors 2009 - 2010, Education  
Chair 2008 - 2011, Conference Co-Chair 2007  
- 2008

CSI Palm Beach, President-Elect 2002 -  
2003, Education Chair 2002 - 2003, Board of  
Directors 2001 - 2002

# Kenneth R. Gehringer

AIA, NCARB, CDT, CCCA, NYSCEO

Assistant Vice President,  
Studio Director

## Memberships

American Institute of Architects  
Construction Specifications Institute  
International Code Council

## Presentations

Masterformat, 2004 - 2005  
Lorman - Building Codes, 2006 - 2007  
Special Inspections, February 2023

## Honors/Awards

CSI Long Island Chapter President's Award,  
2005, 2011, 2017, 2018, 2019

Locust Valley Water District Rehabilitation  
& Storm Hardening of Pump Station No. 4:  
2023 ACEC NY Silver Award

The Cornerstone Yorkshire, Lynbrook:  
Vision LI 2020 Smart Growth Award &  
LIBN 2021 Real Estate A/E Awards - Top  
Commercial Development

South Huntington Water District Plant No. 9:  
2018 ACEC NY Gold Award

Roslyn Water District Wellhead Treatment at  
Plant No. 4: AWWA NY Section 2017 Project  
of the Year - Small Sized Project & 2017  
ACEC NY Gold Award

CSI Long Island Chapter Anthony P. Bruno  
Distinguished Service Award, 2010

Cambridge Who's Who, 2009

PGT Architectural Showcase, First Place  
Winner, 2002

Strathmore Who's Who, 2001

Gold Medal for Achievement in Arch.  
Technology, 1993

Who's Who in American Colleges &  
Universities, 1993

NYIT Honor Society, 1991

NYIT President's Award, four time recipient  
Summa Cum Laude



- Township of Parsippany-Troy Hills Water Department Replacement of Well 20R; Parsippany, NJ: Responsible for architectural services for the replacement of a well and new plant with split-faced block structure and timber-framed trussing. The design matched the aesthetic of the surrounding neighborhood.
- Roslyn Water District AOP Treatment at Plant No. 4; Roslyn, NY: Provided architectural services for a new masonry building to store a permanent AOP system for the treatment of 1,4-dioxane and PFAS at the District's Plant No. 4.
- Dix Hills Water District Rehabilitation of Plant No. 3; Dix Hills, NY: Provided architectural services to rehabilitate and modernize the existing Plant No. 3. The project scope included new roofs, windows, and doors; ceiling replacement; and epoxy painting of floors.
- Middlesex County Utilities Authority (MCUA) Advanced Anaerobic Digestion Facility; Sayreville, NJ: As a subconsultant to Greeley and Hansen, provided architectural services to support the design and construction of a new advanced anaerobic digestion facility at the MCUA Central Treatment Plant.
- Bethpage Water District Administration Building Renovation; Bethpage, NY: Responsible for architectural services for the proposed renovation of the District's administration building. The scope of work involved renovations of the existing office area and garage to create new administrative office spaces, conference/board room, kitchen and employee lounge, and toilet rooms.
- Bethpage Water District New Garage; Bethpage, NY: Provided architectural services for the design and construction of a new building housing parking spaces for trucks; garage door entries on the south and east facades to accommodate vehicle circulation through the site; employee lounge, toilet rooms with showers and lockers, and an office; a storage mezzanine; and mechanical service spaces.
- Franklin Square Water District PFOS Treatment at Plant No. 1; Franklin Square, NY: Provided architectural services associated with an emergency project to design and prepare plans and specifications for a new wellhead treatment system for PFOS removal at the District's Schroeter Avenue Plant (Plant No. 1).
- Hicksville Water District AOP Treatment at Plant No. 1; Hicksville, NY: Responsible for architectural services in connection with the design and construction of AOP/GAC treatment and booster buildings.
- Hicksville Water District AOP and PFAS Treatment at Plant No. 6; Hicksville, NY: Responsible for architectural services in connection with the design and construction of an AOP/GAC treatment building. The project also included design for the replacement of various roofing systems at existing buildings within Plant No. 6.
- Village of Garden City AOP Treatment at Plant No. 9; Garden City, NY: Responsible for architectural services in connection with the design and implementation of a permanent AOP/GAC system for the treatment of 1,4-dioxane and PFAS at the Well No. 9 plant site.
- South Huntington Water District AOP Treatment at Plant No. 3; Huntington Station, NY: Provided architectural design services for the extension of the treatment building at Plant No. 3 to accommodate an AOP treatment system.
- Hicksville Water District AOP Treatment at Plant No. 8; Hicksville, NY: Responsible for architectural services in connection with the design and construction of an AOP treatment system and GAC building. The free standing masonry structure conforms to the surrounding residential neighborhood and matches the existing masonry well house building.
- Jericho Water District AOP Treatment at Merry Lane; Jericho, NY: Provided architectural services for the design of a treatment facility for the removal of 1,4-dioxane. The treatment system is an AOP followed by GAC filtration.
- Town of Hempstead Department of Water Wellhead Treatment for Emerging Contaminants and Nitrate Removal at Well Nos. 1A and 2A; Levittown, NY: Responsible for architectural design services for the construction of a two-story treatment building to treat nitrate and emerging contaminants.
- Town of Hempstead Department of Water Wellhead Treatment for Emerging Contaminants Removal at Well No. 13; Levittown, NY: Responsible for architectural design services for the construction of a two-story treatment building to treat emerging contaminants within the Levittown Water District.
- Town of Hempstead Department of Water Wellhead Treatment for Emerging Contaminants Removal at Well Nos. 5A and 5B; Levittown, NY: Responsible for architectural design services for the construction of a two-story treatment building to treat emerging contaminants within the Levittown Water District.
- Town of Hempstead Department of Water AOP Treatment at Well Nos. 7A and 8A; Levittown, NY: Responsible for architectural design services for the construction of a new AOP and GAC treatment building.



**Thein Win, P.E., Senior Vice President  
Hilliers Electrical Engineering, Inc.**

**Education**

Bachelor of Science in Electrical Engineering, 2001  
Alfred University, Alfred, NY

**Professional Registration**

Registered Electrical Engineer: Florida No. 65722

**Experience**

24 years of electrical and I&C design, programming, and construction management.

*Hilliers Electrical Engineering, Inc., 2001 to present*

Engineering, design, and construction services experience includes medium and low voltage electrical distribution systems, instrumentation and control systems design and implementation. Supervisory control and data acquisition (SCADA) systems experience in water treatment facilities and wastewater treatment facilities.

Electrical and I&C design for projects of nanofiltration treatment, reverse osmosis treatment, lime softening, and wastewater treatment plants including reclaimed water systems, aquifer storage and recovery (ASR) wells, and wellfields. Programming of PLC and HMI for lift stations, raw water wells, water and wastewater treatment plants.

Performed design and construction services for various fire detection/suppression and alarm systems, communication networks, and telephone networks. Designed and supervised the construction of remote gate operators, card readers, and remotely operated CCTV security systems and process monitoring systems.

Performed lighting and power distribution design for roadways, parks, sports fields, and parking lots, including point-by-point illumination calculations and voltage drop calculations.

Skills include preparation and presentation of specifications, value engineering, energy analysis, testing, cost estimates, start-up, and onsite inspections for water and wastewater treatment projects. Proficiency with SKM Power Tools™ for Windows Dappers, CAPTOR and TMS; AutoCAD, SolidWorks, AGI32, Dialux, LitePRO, PLC programming, and HMI programming.

**Professional Membership**

Institute of Electrical and Electronic Engineers (IEEE)  
Instrument Society of America (ISA)  
LEED Accredited Professional



**Thein Naing, Electrical and Instrumentation Design  
Engineer & Field Engineering Inspector  
Hillers Electrical Engineering, Inc.**

**Education**

Bachelor of Electrical Engineering, 2006  
University of Hertfordshire, Hatfield, UK

**Experience**

19 years of electrical and I&C design, and construction management.

*Hillers Electrical Engineering, Inc., 2007 to present:*

Engineering, design, and construction services experience includes medium voltage and low voltage electrical distribution systems, instrumentation and control systems design and implementation. Supervisory control and data acquisition (SCADA) systems, Remote Telemetry Units (RTU), and communication systems for lift stations, wellfield, water treatment facilities, and wastewater treatment facilities.

Performed design and construction services for various fire detection/suppression and alarm systems, communication networks, and telephone networks. Designed and supervised the construction of remote gate operators, card readers, and remotely operated CCTV security systems and process monitoring systems.

Performed lighting and power distribution design for roadways, parks, sports fields, and parking lots, including point-by-point illumination calculations and voltage drop calculations.

Skills include preparation of specifications, value engineering, energy analysis, testing, cost estimates, start-up, and onsite inspections for lift stations, wellfield, water and wastewater treatment projects. Proficiency with AutoCAD, AGI32 and LitePRO.

**Professional Membership**

Institute of Electrical and Electronic Engineers (IEEE)

## CHUCK SCHRAMM, PSM

### DIRECTOR OF SURVEY AND MAPPING



With nearly 4 decades of geospatial experience, Chuck Schramm's leadership brings valuable insights, streamlines data collection, and improves the overall accuracy and efficiency of our projects. With his guidance, our survey team is poised to achieve new heights in quality and impact. His responsibilities include daily operations of the surveying department, estimating, project progress reporting, coordination with other departments and clients, and business development. He also has extensive experience with a variety of engineering and surveying-related computer software, including Bentley OpenRoads Designer (ORD), MicroStation, and GEOPAK, and experience in NPDES documentation.

#### TOTAL YEARS OF EXPERIENCE

36 years (1/9/1989)

#### POST REGISTRATION EXPERIENCE

31 years (7/6/1994)

#### LICENSES

Professional Land Surveyor, LS5366, FL, 1994

#### EDUCATION

BS, University of Florida, Survey and Mapping, 1988

Courses Completed, Florida Institute of Technology, 1984

### RELEVANT PROJECT EXPERIENCE

**Port Everglades Maintenance Building New Site, FL: Survey Manager.** KEITH provided planning, civil engineering, and landscape architecture design along with survey, SUE and UC for Port Everglades to construct a new facility to consolidate Port Facilities Maintenance and Operations from the current functions that are located within various buildings throughout the Port Everglades Campus into a central location. KEITH is conducting a Boundary and Topographic Survey of the site, covering the area between SE 20th St, SE 22nd St, SE 14th St, and Eisenhower Boulevard. The survey will include all surface features, trees, and utility markings, and will be referenced to the Florida State Plane Coordinate System (NAD83/11) and NAVD88. Additionally, the KEITH Team will perform a Title Search and incorporate any encumbrances into the survey. For Subsurface Utility Engineering (SUE), KEITH will follow ASCE Standard 38-02 to designate, locate, and map existing subsurface utilities. This includes marking utilities with Ground Penetrating Radar (GPR) and performing up to 12 test holes to expose utilities. Utility record research will be conducted to identify utility owners and develop a composite drawing. KEITH will also provide utility mapping and horizontal designation services, ensuring accuracy and resolving any discrepancies.

**Water Service Material Validation, Broward County, FL Survey Manager.** KEITH, under this continuing service contract, provided civil engineering services for this Water Service Material Validation project. This project supported compliance with the EPA's Lead and Copper Rule Improvements (LCRI) by identifying and validating the materials of existing water service lines within the County's drinking water system. The scope included predictive modeling, field investigations, and integration of findings into BCWWS's GIS system. KEITH performed visual inspections and vacuum excavations to verify service line materials, documented findings, and supported data-driven decision-making. The project also involved the use of Trinnex's LeadCAST software to enhance predictive modeling capabilities.

**Racetrack Logistics Center, Broward County, FL Survey Manager.** KEITH is assisting the Client in the development of a KEITH Facility project called Live! Resorts Pompano - Industrial Parcels consisting of four parcels equaling up to 1.5 million-SF of industrial space on an approximately 95.8-acre site. KEITH provides professional services to the Client including civil engineering, planning, landscape architecture, and construction program administration. KEITH is assisting the Client in meetings with government agencies/permit authorities, site plan preparation and amendments, building permitting, final engineering documents including paving, grading, and



drainage plans, pavement marking and signing plans, water distribution, sanitary sewer, and lift station plans, erosion control and demolition plans, engineering permitting, final landscape construction documents including hardscape and layout plan, grading plan, sitework details, irrigation and lighting plans, a tree disposition plan, and construction administration and program management through inspection and final certifications.

**Town Of Surfside Gen Engineering, Miami-Dade County, FL Survey Manager.** As part of the Town of Surfside's General Engineering Contract, KEITH provides the Town with civil services to support the development of various projects related to the Town's infrastructure. Projects under this contract include: NPDES MS-4 Monitoring and Reporting: KEITH is responsible for providing professional engineering services for National Pollutant Discharge Elimination Systems (NPDES) and Stormwater Regulatory Monitoring and Compliance Reporting to the Florida Department of Environmental Protection (FDEP) on behalf of the Town. KEITH is responsible for processing the required annual reporting of the Town's current NPDES MS-4 Permit to FDEP. Abbott Avenue Phase 1 and Phase 2 Drainage Improvements: KEITH assisted with drainage improvements on Abbott Avenue. KEITH provided services including civil engineering and utility coordination. The KEITH Team evaluated and assessed the existing stormwater drainage conditions, prepared reports and cost estimates from ICPR models and calculations for seven improvement options and presented conclusions for the selection of the best and most cost-effective solution. KEITH also evaluated existing land use development codes, stormwater ordinances, and MS-4 reporting with recommendations and ordinance revisions for compliance and exceedance of federal, state, and local requirements. Sea level rise projections in accordance with Southeast Florida Regional Climate Change Compact were considered in assessments. KEITH assisted in securing a 2022 FDEP Flooding and Sea Level Resiliency Grant to cover most of the estimated construction costs. MD-RER Sanitary Sewer Certification: KEITH provided civil engineering services for the 5-Year Update certification required by Miami-Dade County. KEITH conducted reviews of the existing sanitary sewer and transmission model and supplied information regarding upgrades and modifications to the Town.

**Drainage Improvements at US1 And NE 14th St, Broward County, FL Survey Manager.** KEITH, under its continuing contract with the City, is providing civil engineering, surveying, and subsurface utility engineering for this US1 and NE 14th Street Drainage Improvement project. This comprehensive drainage improvement project aims to significantly enhance the stormwater management system in the City of Pompano Beach. The project involves the installation of new storm drainage infrastructure and the cutting of swales to optimize drainage functionality and mitigate flooding risks. This project area primarily consists of residential properties. Key components of the project include: • Installation and Reconstruction: A total of 54 storm drain structures will be installed or reconstructed to ensure efficient water flow and prevent blockages. • Storm Drain Piping: Approximately 4,765 linear feet of storm drain piping will be laid to facilitate the effective conveyance of stormwater. • Enhanced Drainage Functionality: The project will incorporate advanced engineering techniques to improve the overall drainage capacity and resilience of the area. TBG Consulting provided cost estimating services to ensure that the project remains within budget while achieving its goals of improved drainage and reduced flood risk. This initiative is a critical step towards enhancing the infrastructure and safety of Pompano Beach.

**First 95 Distribution Center – Phase II, Broward County, FL Survey Manager.** This comprehensive project is a proposed industrial project that includes demolition of an existing 44,328-square-foot industrial warehouse building and construction of a proposed new 140,120-square-foot industrial building with approximately 104 parking spaces and loading operations at the rear of the building. The proposed site features 2 driveway access points from NW 15th Street, with vehicular circulation around a centrally located building. The project site has a land use designation of Industrial and a zoning designation of General Industrial (I-1) and is located in Pompano Beach's prominent industrial district. NW 15th Street is a Broward County road that provides direct access to a major arterial (Powerline Road) and a collector (Dixie Highway), which in turn connect to I-95 and the Florida Turnpike. KEITH provides full survey, SUE, land planning, civil engineering, traffic engineering, and landscape architecture services for the site.

## KELLI SCHUELER, PLA, LEED AP

DIRECTOR OF LANDSCAPE ARCHITECTURE



An experienced landscape architect and dedicated project manager, Kelli Schueler provides planning, design and project management services for a wide variety of project types through all phases of the development process. Her knowledge of the local environment, innovative technologies and sustainable best practices is combined with a creative approach that is detail oriented, ensuring designs are implemented both efficiently and accurately. Kelli has a wide range of project experience, but is most motivated by the opportunity to create special moments within the urban environment where hardscape and architectural elements are thoughtfully combined with green space to create impactful places of respite and community within the urban core.

### TOTAL YEARS OF EXPERIENCE

21 years (2/23/2004)

### POST REGISTRATION EXPERIENCE

11 years (6/11/2014)

### LICENSES

LEED AP, NULL

Professional Landscape Architect, LA6667565,  
2021

Professional Landscape Architect, 2959, TX, 2014

### EDUCATION

BS, Oklahoma State University, Landscape  
Architecture, 2003

### CERTIFICATIONS

LEED AP

## RELEVANT PROJECT EXPERIENCE

**Pompano Public Safety Complex, Broward County, FL: *Landscape Architect.*** KEITH provided civil engineering and geospatial services for the 70,000 square foot Pompano Beach Public Safety Complex which included a 59,000 square foot BSO office and a 10,500 square foot Fire Station. KEITH's services included paving, grading, and drainage plans, water distribution and sanitary sewer plans, pavement marking and traffic signage plans, erosion and sediment control plans, engineering permitting, surveying & mapping, and subsurface utility engineering services as well as landscape architectural services. Tree disposition plans, landscape plans, and construction documents were provided. Additionally, KEITH provided construction observation and certification.

**Pompano Beach Ocean Rescue Headquarters, Broward County, FL *Landscape Architect.*** KEITH assisted the Client in developing a KEITH Facility project including the addition of a 3,449-SF second floor to the existing Ocean Rescue Building increasing the total to 5,369-SF. The second-floor addition will include meeting rooms, bathrooms, an IT room, break rooms, and storage. Stakeholder input, including Ocean Rescue personnel, was incorporated throughout the design process. KEITH provided civil engineering, planning, landscape architecture, and construction program management services. The KEITH Team assisted the Client in planning due diligence, drainage, water and wastewater, civil and site design concept plans, preliminary civil engineering through site plan/DRC, engineering construction documentation including paving, grading, and drainage plan, pavement marking and signing plan, water distribution and sanitary sewer plan, erosion control and demolition plan, engineering permitting involving Broward County Environmental Protection and Growth Management Department, FDEP Stormwater, FDEP NPDES/SWPP, Pompano Beach Engineering, and Broward County Traffic Engineering, landscape schematic design through site plan/DRC, tree inventory and appraisal by in-house Certified Arborist, construction documentation, construction observation, inspections, and final certifications. The completed project will further enhance the City's Ocean rescue resources for community safety.



**Pompano Beach Fire/Emergency Operations Center, Broward County, FL: *Landscape Architect.*** KEITH assisted the Client, as subconsultant, in developing a KEITH Facility project that includes a new fire, rescue, and logistics complex to include administrative and emergency operations center, and a fire and EMS distribution center with storage for emergency apparatus. KEITH provided services to the Client including civil engineering, LEED consulting, survey, landscape architecture, and construction management. The project created a state-of-the-art facility in the Downtown Pompano Transit Oriented Corridor (DPTOC).

**Fort Lauderdale Police Station, Broward County, FL: *Landscape Architect.*** KEITH, as subconsultant to AECOM, assisted the Client in the development of a KEITH Facility project including the demolition of existing buildings and the design and construction of a new Police Headquarters. KEITH provided full services to the Client including civil and traffic engineering, survey/SUE, utility coordination, planning, landscape architecture, and construction program management. The new headquarters, built in phases, began with the parking garage, firing range, and perimeter landscape buffers to neighboring residents. Phase two included initial site development, SW 13th Avenue extending up to the existing fleet maintenance facility, restriping of existing surface parking, and replacement of the radio tower. Demolition of outparcel buildings and construction of the new facility, including central plant, were phase three. Lastly, demolition of the old facility and a portion of the fleet maintenance facility followed by final site development including extension of SW 13th Avenue to Broward Boulevard, the creation of a linear park along Broward Boulevard, and the removal of all remaining surface parking and outparcel buildings. The project leaves the City of Fort Lauderdale with a state-of-the-art public safety headquarters to better serve the community.

**Deerfield Beach City Hall Remodel, Broward County, FL: *Landscape Architect.*** KEITH, as subconsultant, managed a multi-disciplinary team, assisted the Client in the development of a KEITH Facility/KEITH Campus/KEITH Life project including a Design Criteria Package (DCP). KEITH in-house services included planning, landscape architecture, civil engineering, survey, and traffic engineering. The DCP was created for the renovation of Deerfield Beach City Hall to update efficiencies in parking, logistics, and water systems. The plans included the rework of the existing site plan to incorporate concrete curbing and additional building of 726-SF on the west side abutting NE 2nd Avenue. The KEITH Team coordinated with the City for the location of signage in parking areas, code compliant civil and landscape plans, analysis and adjustments to stormwater systems, and utility wire relocation. KEITH coordinated with the MEP for fire sprinkler water line design and provided peer review of the design and construction documents for landscape architecture and civil engineering elements. The project brings the hub of the City of Deerfield Beach community up to the contemporary standards on which the community depends.

**Palm Beach International Airport New ARFF Facility, Palm Beach County, FL: *Landscape Architect.*** KEITH, a subconsultant, completed professional services for civil engineering, subsurface utility engineering, and landscape architecture. KEITH performed utility designation and location investigation services with the purpose of determining the horizontal and vertical location of the 12" waterline running along the south side of Taxi-way M. Utility designation services were in accordance with ASCE/C-1 38-02, Quality Level B, in the immediate location of the proposed work. A list of the subsurface utilities in the project area were obtained through a review during the Data Collection and Records Research task. Electromagnetic induction (EM), in conjunction with Ground Penetrating Radar (GPR), was used to identify any detectable utilities within the footprint of the project. All marks were reviewed with on-site personnel/surveyors in the field. Utility location services: four (4) vacuum excavations were utilized to confirm/verify any discoveries identified during the EM and GPR evaluation.

## MARK MITCHELL

### DIRECTOR OF SUBSURFACE UTILITY ENGINEERING



As Director of Subsurface Utility Engineering (SUE) for KEITH's Utilities Division, Mark Mitchell is responsible for oversight of the day-to-day operations of all subsurface utility engineering projects, along with utility records research, conflict analysis, and determining if additional utility investigation is needed for assigned projects. He has completed projects from beginning phases through final delivery, including preparing and submitting fee proposals, client coordination, setting up projects for field crews, conducting field visits when troubleshooting is required, downloading and processing collected data, performing quality control, finalizing for delivery, and keeping clients informed daily. His experience includes creating DTMs, topos, TIN models, PNCs, and test hole summary spreadsheets. Mark serves as a liaison between the design team, utility agencies, and owners on behalf of clients to provide utility coordination, documentation, inter-coordination, and maintenance of files of all activities for each utility agency.

#### TOTAL YEARS OF EXPERIENCE

25 years (11/1/1999)

#### EDUCATION

AA, Saint Petersburg College, Arts, 1992

#### CERTIFICATIONS

OHS Construction Induction Training Certificate  
 OSHA Confined Space Entry  
 Rail Industry Safety Induction (RISI)  
 CSX Certified Safety Facilitator  
 OSHA 40-Hour Safety Training

### RELEVANT PROJECT EXPERIENCE

**Pompano Beach Water and Re-Use Treatment Plant Projects CSC, Broward County, FL: *Project Manager*:** KEITH, as a subconsultant, assists in the development of water and re-use water treatment plant projects on an as-needed basis. KEITH assists the Client with survey, SUE, and landscape architecture services. The KEITH Team assists the Client with topographic survey, specific purpose survey, subsurface utility engineering, site plan processing, paving, grading, and drainage, erosion plan, water distribution and sanitary sewer, engineering permitting, landscape architecture plans, construction observation, and construction certification.

**Broward Reclaimed Water Plant Expansion, Broward County, FL: *Project Manager*.** KEITH, as subconsultant to Brown and Caldwell, assisted the Client in developing a KEITH Facility project that included the expansion of the North Regional Wastewater Treatment Plant (NRWWTP) to bring it in line with updated State Ocean Outfall Rules and increases in Baseline Flow percentages. KEITH provided services to the Client including survey/SUE and landscape architecture. The KEITH Team assisted the Client in utilizing SUE techniques within the plant and for proposed yard piping routing, Ground Penetrating Radar (GPR) to designate, verify, and document location of underground facilities, major piping, conduits, and stormwater facilities, supplemental topographic survey verifying the elevation of hydraulic process structures, landscape architecture concepts associated with the exterior design and construction of two buildings, tree inventory and analysis, landscape, irrigation, and tree disposition plans, and detailed engineering services for the yard piping. The NRWWTP utilized a 54-inch ocean outfall and Class I Injection Wells as the primary means of treated effluent disposal. Legislation by the State of Florida, generally known as the "Ocean Outfall Rule", eliminated the use of ocean outfalls for disposal after 2025. The Outfall Rule also mandates the implementation of a wastewater reclamation program with a minimum capacity of 60 percent of the facility's Baseline Flow above and beyond current reclaimed water application. This mandate equals the required total reclaimed water production of approximately 26 mgd. With the implementation of these upgrades and improvements the NRWWTP now has a firm-rated capacity within the state law requirements.



**Southern Regional Wastewater Treatment, Broward County, FL: *Project Manager.*** KEITH was tasked to provide subsurface utility engineering services for up to 5 days of horizontal utility designation within the project limits of the City of Hollywood Water Treatment Facility. Additionally, a 10' radius of 5 soil borings were included in the investigation. Findings were painted and flagged in the field.

**Springtree Water Treatment Plant, Broward County, FL: *Project Manager.*** KEITH, as subconsultant, horizontally marked any known tone able and non-tone able underground utilities that were represented on as-built plans, above ground appurtenances, and other miscellaneous utility records. Conductive utilities were marked on the surface utilizing active geophysical prospecting techniques in conjunction with electromagnetic equipment utilizing passive radio and audio frequencies. Known non-conductive utilities and/or structures were marked on the surface utilizing Ground Penetrating Radar (GPR), above ground features, professional judgment, utility plats and/or as-builts. KEITH Team members also performed up to twenty (20) test holes at specific sites requested by the design engineer. Test holes were utilized to expose utilities to minimize any potential for damage. Test holes were performed of minimum size (usually 1' by 1').

**Pompano Beach Chiller Plant, Broward County, FL: *Project Manager.*** The project included a 750 square foot chiller plant building and cooling tower yard for Pompano Beach City Hall. The new chiller plant will provide energy efficient air-conditioning to City Hall and the Commission Chambers while reducing energy costs to the City. The impacted area around the proposed chiller plant increased the entire site pervious area by 619 square feet and also required the elimination of four parking spaces. KEITH provided planning, civil, survey, and SUE services including layout and processing of the site plan, utilities design and permitting through all agencies having jurisdiction.

**Port Everglades New Office Building, Broward County, FL: *Project Manager.*** KEITH assisted the Client in developing a KEITH Life/KEITH Facility/KEITH Campus/KEITH Access project that includes the design, permitting, and construction contract administration associated with development of new cargo handling container yards and ancillary buildings (Phase IX-B). The container yards are integral to the expansion of Port Everglades' Southport Turning Notch. A second component of the project included environmental assessment and demolition of the existing Foreign-Trade Zone warehouse and conversion of the site into a cargo handling container yard facility (Phase IX-A). KEITH provided services to the Client in land-side civil engineering, planning, and survey/SUE. The KEITH Team assisted the Client in topographic survey, horizontal designation, vacuum excavation, stormwater management design and permitting, water design for hydrant system design and permitting, and a Written Statement of Probable Construction Cost for stormwater management and water system construction improvements. The project further enhanced the world-class facility ensuring future expandability, safety, and services at the port.

**Palm Beach County Water Treatment Plant, Palm Beach County, FL: *Project Manager.*** The client requested that KEITH, as subconsultant, provide utility designating and clearance test holes prior to soil borings at the Palm Beach County Water Treatment Plant in Delray Beach. Utilities were designated within a 10' radius of 5 proposed pre-staked soil boring points. Additionally, test holes were performed for clearance purposes at all 5 locations. Keith vacuum excavated to 5' and "probed" for utilities with a compressed air lance to 10' or refusal.

**Name:** Reza Javidan, P.E.

**Education:** B.S. (Civil Engineering), University of Detroit, MI, 1986  
M.S. (Civil Engineering), University of Detroit, MI 1988

**Licenses:** Professional Engineer, Registered in the State of Florida, 2003

**Work Experience:**

2015 - Present	Project Engineer Quest Engineering Services & Testing, Inc. Pompano Beach, Florida.
2009 - 2015	Project Engineer Florida Engineering & Testing, Inc. Pompano Beach, Florida.
2004 - 2009	Senior Geotechnical Engineer Nutting Engineering of Florida Boynton Beach, Florida
2000 - 2004	Geotechnical Engineer ATC, Inc., Miami, Florida
1993 - 2000	Geotechnical Engineer Toos-Ab Engineering, Inc., Mashad, Iran.
1989 - 1993	Project Engineer Bowser-Morner Associates, Inc., Toledo, Oh

**Relevant Skills:** Geotechnical Studies and Foundation Design Recommendations  
Foundation Installation Inspections & Pile Load Tests  
Field and Laboratory Tests on Soil, Concrete, Masonry, Asphalt  
Structural (Special) Inspections  
Project Management

**Relevant Projects:** Trump Plaza, Hallandale Beach, FL  
Office Max Headquarter Building, Boca Raton, FL  
State School QQQ, Miami, FL  
Sunset Lakes Elementary School, Miramar, FL  
BCC-Central Campus, Proposed Parking Garage, Davie, FL  
North Broward Waste Water Treatment Plant, Pompano Beach, FL  
Broward County Fire Rescue – Station 34, North Lauderdale, FL  
Ft. Lauderdale/Hollywood International Airport, Ft. Lauderdale, FL

Mr. Javidan has over 30 years of engineering industry experience of which over 17 years have been in South Florida. He has worked on hundreds of projects such as roadways, utilities, public facilities, commercial projects, residential projects, providing construction materials testing, geotechnical engineering, structural inspections, wind load evaluations as well as engineering consultations with regard to roofing and ground vibrations.

**QuEST**

**Name:** R. N. Sailappan, P.E.

**Education:** B.S. (Naval Architecture), Cochin University of Science & Technology, Cochin, India, 1986  
M.S. (Civil Engineering), Florida Atlantic University, Boca Raton, FL, 1991

**Licenses:** Professional Engineer, Registered in the State of Florida, 1993

**Associations:** Member, American Society for Testing of Materials (ASTM), 2010  
Member, American Society of Civil Engineers (ASCE), 1994  
Member (Former), Institution of Naval Architects (INA), India, 1987

**Work Experience:**

1998 - Present	Principal Quest Engineering Services & Testing, Inc. Pompano Beach, Florida.
1990 - 1998	Engineer & Manager Professional Service Industries, Inc. West Palm Beach, Ft. Lauderdale, Miami, FL
1988 - 1990	Graduate Research Assistant Dept. of Ocean Engineering, Florida Atlantic University Boca Raton, Florida
1986 - 1988	Naval Architect Mazagon Dock Ltd., Mumbai (Bombay), India

**Relevant Skills:** Geotechnical Studies and Foundation Design Recommendations  
Foundation Installation Inspections & Pile Load Tests  
Field and Laboratory Tests on Soil, Concrete, Masonry, Asphalt  
Structural (Special/Threshold) Inspections  
Environmental Site Assessments  
Project Management, Marketing, Business Development

**Relevant Projects:** Miramar East Water Treatment Plant, Miramar, FL  
Sawgrass Water Treatment Plant, Sunrise, FL  
North Broward Waste Water Treatment Plant, Pompano Beach, FL  
Utility Improvements, City of Sunrise, FL  
Miami-Dade Water & Sewer Utility Improvements, Dade County, FL  
Ft. Lauderdale/Hollywood International Airport, Ft. Lauderdale, FL

**Publications**

D. V. Reddy and R. N. Sailappan, "Acoustic Emission as a NDE Tool - Certain Laboratory and Field Investigations", December 1989.

D. V. Reddy, S. K. Lee, R. N. Sailappan, W. H. Hartt & M. Arockiasamy, "Fracture Mechanics Evaluation of the Durability of Fly Ash Concrete", December, 1991.

D. V. Reddy, S. K. Lee, R. N. Sailappan, W. Ahn, G. V. Jeedigunta, and K. P. Bethune, "Corrosion Resistance and Fracture Toughness of High Performance Concrete in the Marine Environment", May-June 1998.

Mr. Sailappan has over 35 years of engineering industry experience, with nearly 33 of those years being in South Florida. He has worked on hundreds of projects such as roadways, utilities, public facilities, commercial projects, residential projects, stadiums and arenas, providing construction materials testing, geotechnical engineering, structural inspections, forensic repair designs, wind load evaluations as well as engineering consultations with regard to roofing, ground vibrations, light and sound analysis.

**QuEST**

# 8. Office Locations

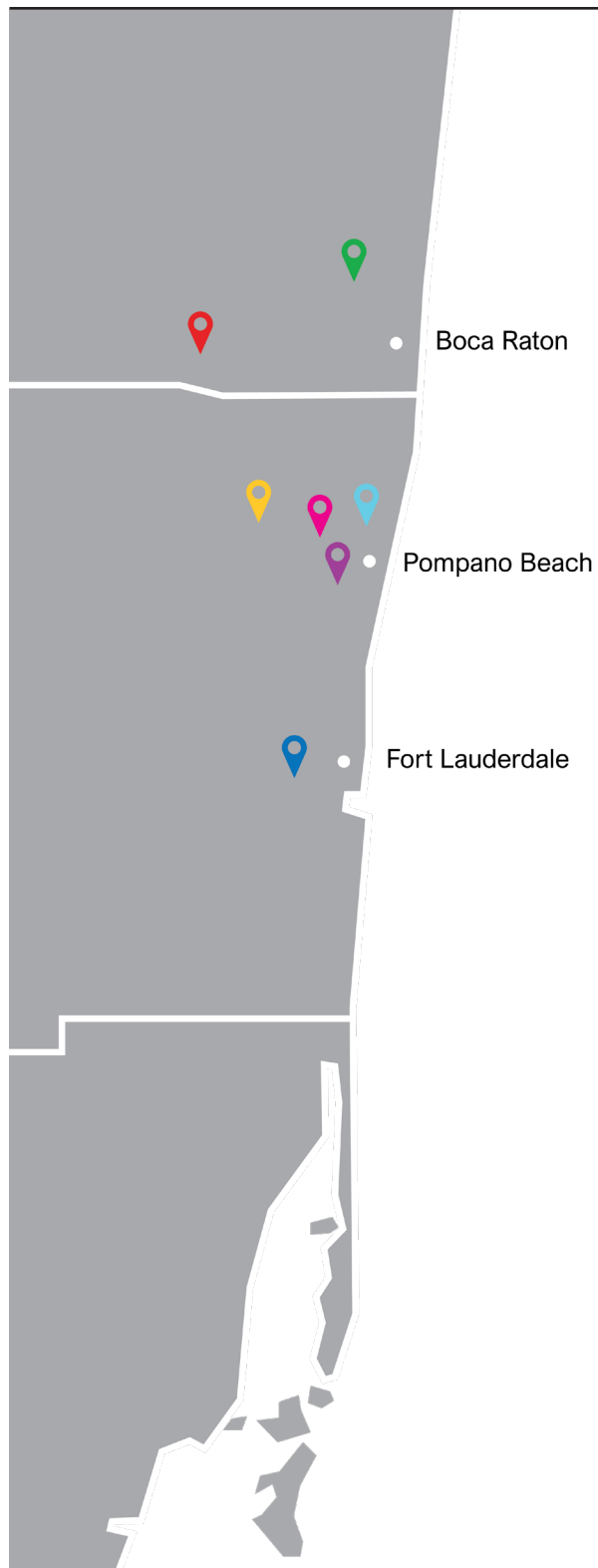

 **City of Pompano Beach WTP**



 **City of Pompano Beach Oasis Reuse Plant**



**PRIME CONSULTANT**

 **McCafferty Brinson Consulting, LLC**  
 633 S Andrews Avenue  
 Suite 402  
 Fort Lauderdale, FL 33301

**SUB-CONSULTANTS**

 **H2M Architects & Engineers, Inc.**  
 951 Yamato Road  
 Suite 202  
 Boca Raton, FL 33431

 **Hillers Electrical Engineering, Inc.**  
 23257 State Road 7 Ste 100  
 Boca Raton, FL 33428

 **QuEST Engineering Services & Testing, Inc.**  
 2737 NW 19th Street  
 Pompano Beach, FL 33069

 **Keith and Associates, Inc.**  
 301 E Atlantic Boulevard  
 Pompano Beach, FL 33060

## 9. Litigation

McCafferty Brinson Consulting LLC (MBC) has no history with citations or violations, and has not been involved with legal proceedings arising from MBC's services, to include arbitration, lawsuits, bankruptcies against the firm in the last five years. MBC has never had a contract terminated by the other contract party.

---

## 10. City Forms

(Submitted Electronically via Ionwave: <https://pompanobeachfl.ionwave.net>)

---

## 11. Reviewed and Audited Financial Statements

(Submitted Electronically via Ionwave: <https://pompanobeachfl.ionwave.net> as confidential documents)





*McCafferty Brinson Consulting, LLC has been proud to assist the City of Pompano Beach with its Water and Reuse Treatment Plant Projects and looks forward to serving the City.*



# Request for Taxpayer Identification Number and Certification

Go to [www.irs.gov/FormW9](http://www.irs.gov/FormW9) for instructions and the latest information.

Give form to the  
requester. Do not  
send to the IRS.

**Before you begin.** For guidance related to the purpose of Form W-9, see *Purpose of Form*, below.

**1** Name of entity/individual. An entry is required. (For a sole proprietor or disregarded entity, enter the owner's name on line 1, and enter the business/disregarded entity's name on line 2.)  
**McCafferty Brinson Consulting, LLC**

**2** Business name/disregarded entity name, if different from above.  
**NA**

**3a** Check the appropriate box for federal tax classification of the entity/individual whose name is entered on line 1. Check only **one** of the following seven boxes.  
 Individual/sole proprietor     C corporation     S corporation     Partnership     Trust/estate  
 LLC. Enter the tax classification (C = C corporation, S = S corporation, P = Partnership) . . . . . **S**  
**Note:** Check the "LLC" box above and, in the entry space, enter the appropriate code (C, S, or P) for the tax classification of the LLC, unless it is a disregarded entity. A disregarded entity should instead check the appropriate box for the tax classification of its owner.  
 Other (see instructions)

**4** Exemptions (codes apply only to certain entities, not individuals; see instructions on page 3):  
Exempt payee code (if any) \_\_\_\_\_  
Exemption from Foreign Account Tax Compliance Act (FATCA) reporting code (if any) \_\_\_\_\_  
*(Applies to accounts maintained outside the United States.)*

**3b** If on line 3a you checked "Partnership" or "Trust/estate," or checked "LLC" and entered "P" as its tax classification, and you are providing this form to a partnership, trust, or estate in which you have an ownership interest, check this box if you have any foreign partners, owners, or beneficiaries. See instructions . . . . .

**5** Address (number, street, and apt. or suite no.). See instructions.  
**633 S. Andrews Avenue, Suite 402**

**6** City, state, and ZIP code  
**Fort Lauderdale, FL 33301**

**7** List account number(s) here (optional)

Requester's name and address (optional)

**Part I Taxpayer Identification Number (TIN)**

Enter your TIN in the appropriate box. The TIN provided must match the name given on line 1 to avoid backup withholding. For individuals, this is generally your social security number (SSN). However, for a resident alien, sole proprietor, or disregarded entity, see the instructions for Part I, later. For other entities, it is your employer identification number (EIN). If you do not have a number, see *How to get a TIN*, later.

**Note:** If the account is in more than one name, see the instructions for line 1. See also *What Name and Number To Give the Requester* for guidelines on whose number to enter.

Social security number									
			-						
or									
Employer identification number									
2	0	-	4	3	8	2	3	7	1

**Part II Certification**

Under penalties of perjury, I certify that:

- The number shown on this form is my correct taxpayer identification number (or I am waiting for a number to be issued to me); and
- I am not subject to backup withholding because (a) I am exempt from backup withholding, or (b) I have not been notified by the Internal Revenue Service (IRS) that I am subject to backup withholding as a result of a failure to report all interest or dividends, or (c) the IRS has notified me that I am no longer subject to backup withholding; and
- I am a U.S. citizen or other U.S. person (defined below); and
- The FATCA code(s) entered on this form (if any) indicating that I am exempt from FATCA reporting is correct.

**Certification instructions.** You must cross out item 2 above if you have been notified by the IRS that you are currently subject to backup withholding because you have failed to report all interest and dividends on your tax return. For real estate transactions, item 2 does not apply. For mortgage interest paid, acquisition or abandonment of secured property, cancellation of debt, contributions to an individual retirement arrangement (IRA), and, generally, payments other than interest and dividends, you are not required to sign the certification, but you must provide your correct TIN. See the instructions for Part II, later.

**Sign Here**    Signature of U.S. person *Chau McCafferty*    Date 1/23/2025

**General Instructions**

Section references are to the Internal Revenue Code unless otherwise noted.

**Future developments.** For the latest information about developments related to Form W-9 and its instructions, such as legislation enacted after they were published, go to [www.irs.gov/FormW9](http://www.irs.gov/FormW9).

**What's New**

Line 3a has been modified to clarify how a disregarded entity completes this line. An LLC that is a disregarded entity should check the appropriate box for the tax classification of its owner. Otherwise, it should check the "LLC" box and enter its appropriate tax classification.

**Purpose of Form**

An individual or entity (Form W-9 requester) who is required to file an information return with the IRS is giving you this form because they

## City of Pompano Beach

## RLI25-072 WATER AND REUSE TREATMENT PLANT PROJECTS - CONTINUING CONTRACTS (CCNA)

## Position Classification &amp; Maximum Hourly Labor Rate Schedule

<b>Prime /Firm Name</b>	McCafferty Brinson Consulting, LLC
-------------------------	------------------------------------

Position / Classification	Maximum Hourly Rate (\$)
Chief Engineer (PE)	\$320.00
Principal Engineer (PE)	\$275.00
Senior Engineer (PE)	\$215.00
Engineer II (PE)	\$165.00
Engineer I (PE)	\$150.00
Engineer Intern (EI)	\$130.00
Staff Professional	\$130.00
Scientist II	\$130.00
Scientist I	\$120.00
Staff Scientist	\$110.00
Lead Designer	\$170.00
Designer II	\$130.00
Designer I	\$110.00
Construction Manager	\$250.00
Construction Associate	\$200.00
Senior Field Coordinator	\$165.00
Field Coordinator	\$130.00
Administrator	\$115.00
Administrative Assistant	\$75.00

Expert Witness	2.5 x hourly rate
Travel	Per IRS applicable rates
Direct Expenses	1.1 x actual direct costs

## City of Pompano Beach

## RLI25-072 WATER AND REUSE TREATMENT PLANT PROJECTS - CONTINUING CONTRACTS (CCNA)

## Position Classification &amp; Maximum Hourly Labor Rate Schedule

Sub /Firm Name	Hillers Electrical Engineering, Inc.
Position / Classification	Maximum Hourly Rate (\$)
President	\$274.45
Project Manager	\$225.45
Project Engineer	\$179.70
CADD/Technician	\$153.57
Secretarial	\$98.01
Field Inspector	\$169.89

## City of Pompano Beach

## RLI25-072 WATER AND REUSE TREATMENT PLANT PROJECTS - CONTINUING CONTRACTS (CCNA)

## Position Classification &amp; Maximum Hourly Labor Rate Schedule

Sub /Firm Name	H2M architects + engineers
Position / Classification	Maximum Hourly Rate (\$)
Administrative Support Professional	\$110.00
Assistant Department Manager-Coatings	\$172.00
Assistant Department Manager-Eng	\$286.00
Assistant Department Manager-Sci	\$215.00
Assistant Studio Director	\$246.00
BIM / CAD Program Manager	\$226.00
BIM / CAD Specialist	\$140.00
BIM/CAD Project Engineer 1	\$168.00
CAD Technician 2	\$129.00
Coatings Inspector 1	\$112.00
Construction Administrator	\$190.00
Construction Inspector	\$138.00
Department Manager-Coatings	\$315.00
Department Manager-Eng	\$313.00
Department Manager-Sci	\$265.00
Deputy Discipline Director	\$330.00
Deputy Market Director	\$350.00
Director	\$350.00
Discipline Director	\$350.00
Discipline Engineer	\$261.00
Project Architect	\$165.00
Project Designer 1-Arch	\$160.00

## City of Pompano Beach

## RLI25-072 WATER AND REUSE TREATMENT PLANT PROJECTS - CONTINUING CONTRACTS (CCNA)

## Position Classification &amp; Maximum Hourly Labor Rate Schedule

Sub /Firm Name	H2M architects + engineers
Position / Classification	Maximum Hourly Rate (\$)
Project Engineer 1	\$171.00
Project Engineer 2	\$193.00
Project Executive	\$350.00
Project Scientist 1	\$143.00
Project Scientist 2	\$160.00
Sr. Architect 1	\$220.00
Sr. Architect 2	\$247.00
Sr. Architect 3	\$253.00
Sr. BIM / CAD Specialist 1	\$148.00
Sr. Discipline Engineer	\$313.00
Sr. Discipline Scientist	\$258.00
Sr. Project Architect	\$203.00
Sr. Project Designer 1 - Arch	\$193.00
Sr. Project Document Control Specialist	\$132.00
Sr. Project Engineer 1	\$236.00
Sr. Project Engineer 2	\$255.00
Sr. Project Scientist 2	\$203.00
Staff Designer 1	\$116.00
Staff Designer 2	\$127.00
Staff Engineer 1	\$132.00
Staff Engineer 2	\$138.00
Staff GIS Specialist 2	\$116.00

## City of Pompano Beach

## RLI25-072 WATER AND REUSE TREATMENT PLANT PROJECTS - CONTINUING CONTRACTS (CNNA)

## Position Classification &amp; Maximum Hourly Labor Rate Schedule

Sub /Firm Name	H2M architects + engineers
Position / Classification	Maximum Hourly Rate (\$)
Staff Planner 1	\$110.00
Staff Scientist 1	\$110.00
Staff Scientist 2	\$121.00
Studio Director	\$297.00

## Direct Expense Items

Travel

Per IRS applicable rates

Other

1.1x actual direct costs

## City of Pompano Beach

## RLI25-072 WATER AND REUSE TREATMENT PLANT PROJECTS - CONTINUING CONTRACTS (CCNA)

## Position Classification &amp; Maximum Hourly Labor Rate Schedule

Sub /Firm Name	KEITH and Associates, Inc.
Position / Classification	Maximum Hourly Rate (\$)
Project Executive	\$350.00
Project Manager	\$250.00
Project Controls Specialist	\$150.00
Administrative Assistant	\$125.00
Principal Engineer	\$280.00
Senior Engineer	\$230.00
Professional Engineer	\$200.00
Engineering Designer	\$165.00
Engineering Technician	\$135.00
Principal Landscape Architect	\$280.00
Senior Landscape Architect	\$230.00
Landscape Architect	\$200.00
Landscape Designer	\$165.00
Landscape Technician	\$135.00
Arborist	\$200.00
Planning Director	\$280.00
Planning Manager	\$230.00
Principal Planner	\$200.00
Planner	\$165.00
Planning Technician	\$135.00
Chief Utility Coordinator	\$230.00
Senior Utility Coordinator	\$200.00

## City of Pompano Beach

## RLI25-072 WATER AND REUSE TREATMENT PLANT PROJECTS - CONTINUING CONTRACTS (CCNA)

## Position Classification &amp; Maximum Hourly Labor Rate Schedule

Sub /Firm Name	KEITH and Associates, Inc.
Position / Classification	Maximum Hourly Rate (\$)
Utility Coordinator	\$165.00
Utility Coordinator Technician	\$135.00
Construction Director	\$280.00
Senior Construction Manager	\$230.00
Construction Manager	\$200.00
Senior Inspector	\$180.00
Inspector	\$160.00
Chief Surveyor	\$280.00
Senior Surveyor /SUE	\$230.00
Project Surveyor / SUE	\$200.00
Survey / SUE Analyst	\$165.00
Survey / SUE Technician	\$135.00
Survey UAS/LiDAR Crew	\$250.00
Survey Crew	\$235.00
Utility Designating Crew	\$225.00
SUE Crew	\$400.00
Vacuum Excavation	\$550/Ea.

## City of Pompano Beach

## RLI25-072 WATER AND REUSE TREATMENT PLANT PROJECTS - CONTINUING CONTRACTS (CCNA)

## Position Classification &amp; Maximum Hourly Labor Rate Schedule

Sub /Firm Name	Quest Engineering Services & Testing, Inc.
Position / Classification	Maximum Hourly Rate (\$)
Principal Engineer	\$250.00
Project Engineer	\$200.00
Staff Engineer	\$150.00
Laboratory Technician	\$100.00
Field Technician	\$100.00
Flagman	\$75.00
Unit Rate Expenses	
Mobilization of Drill Rig (Per Day)	\$750.00
SPT Borings (Per Linear Foot)	\$25.00
Casing (Per Linear Foot)	\$8.00
Percolation Test (Each)	\$750.00

**Exhibit C – Cover Page**

**1. Insurance Requirements**

**2. Approved Insurance**

CONSULTANT shall not commence services under the terms of this Agreement until certification or proof of insurance detailing terms and provisions has been received and approved in writing by the CITY's Risk Manager. If you are responding to a bid and have questions regarding the insurance requirements hereunder, please contact the CITY's Purchasing Department at (954) 786-4098. If the contract has already been awarded, please direct any queries and proof of the requisite insurance coverage to CITY staff responsible for oversight of the subject project/contract.

CONSULTANT is responsible to deliver to the CITY for timely review and written approval/disapproval Certificates of Insurance which evidence that all insurance required hereunder is in full force and effect and which name on a primary basis, the CITY as an additional insured on all such coverage.

Throughout the term of this Agreement, CITY, by and through its Risk Manager, reserve the right to review, modify, reject or accept any insurance policies required by this Agreement, including limits, coverages or endorsements. CITY reserves the right, but not the obligation, to review and reject any insurer providing coverage because of poor financial condition or failure to operate legally.

Failure to maintain the required insurance shall be considered an event of default. The requirements herein, as well as CITY's review or acceptance of insurance maintained by CONSULTANT, are not intended to and shall not in any way limit or qualify the liabilities and obligations assumed by CONSULTANT under this Agreement.

Throughout the term of this Agreement, CONSULTANT and all subcontractors or other agents hereunder shall, at their sole expense, maintain in full force and effect the following insurance coverages and limits described herein, including endorsements.

1. Worker's Compensation Insurance covering all employees and providing benefits as required by Florida Statute, Chapter 440. CONSULTANT further agrees to be responsible for the employment, control, and conduct of its employees and for any injury sustained by such employees in the course of their employment. If the firm has **no employees** or (only principals/owners), they may file a statutory exemption or sign the City's Workers' Compensation (WC) waiver if the firm has fewer than four employees.

2. Liability Insurance.

(a) Naming the City of Pompano Beach as an additional insured as CITY's interests may appear, on General Liability Insurance only, relative to claims which arise from CONSULTANT's negligent acts or omissions in connection with CONSULTANT's performance under this Agreement.

(b) Such Liability insurance shall include the following checked types of insurance and indicated minimum policy limits.

**Type of Insurance**

**Limits of Liability**

**GENERAL LIABILITY:** Minimum \$1,000,000 Per Occurrence and \$2,000,000 Per Aggregate  
\* Policy to be written on a claims incurred basis

XX comprehensive form	bodily injury and property damage
XX premises - operations explosion & collapse hazard	bodily injury and property damage
XX underground hazard	
XX products/completed operations hazard	bodily injury and property damage combined
XX contractual insurance	bodily injury and property damage combined
XX broad form property damage	bodily injury and property damage combined
XX independent contractors	personal injury
XX personal injury	
sexual abuse/molestation	Minimum \$1,000,000 Per Occurrence and Aggregate
liquor legal liability	Minimum \$1,000,000 Per Occurrence and Aggregate

\*The city must be listed as Additional Insured and coverage must be Primary & Non-Contributory.

Coverages must include premises/operations, independent contractors, contractual liability, products/completed operations, and broad form property damage.

---

**AUTOMOBILE LIABILITY:** Minimum \$1,000,000 Per Occurrence and Aggregate.

Bodily injury (each person) bodily injury (each accident), Property damage, bodily injury and property damage combined.

XX comprehensive form  
XX owned  
XX hired  
XX non-owned

---

**REAL & PERSONAL PROPERTY**

\_\_\_ comprehensive form Agent must show proof they have this coverage.

---

**EXCESS LIABILITY** Per Occurrence Aggregate

\_\_\_ other than umbrella bodily injury and \$1,000,000 \$1,000,000 property damage combined

---

<b>PROFESSIONAL LIABILITY</b>	Per Occurrence	Aggregate
XX * Policy to be written on a claims made basis	\$1,000,000	\$2,000,000

\*The vendor must maintain coverage with a minimum of \$1,000,000 per claim and \$2,000,000 aggregate for contracts under \$7.5M in construction value. The policy must cover negligent acts, errors, or omissions arising from professional services and the vendor must maintained coverage for the duration of the contract and at least 4 years after project completion.

---

(c) If Professional Liability insurance is required, CONSULTANT agrees the indemnification and hold harmless provisions set forth in the Agreement shall survive the termination or expiration of the Agreement for a period of four (4) years unless terminated sooner by the applicable statute of limitations.

---

<b>CYBER LIABILITY</b>	Per	Occurrence
Aggregate		

\_\_\_ \* Policy to be written on a claims-made basis \$ 1,000,000 \$1,000,000

\_\_\_ Network Security / Privacy Liability  
 \_\_\_ Breach Response / Notification Sublimit (minimum limit of 50% of policy aggregate)  
 \_\_\_ Technology Products E&O - \$1,000,000 (only applicable for vendors supplying technology related services and or products)  
 \_\_\_ Coverage shall be maintained in effect during the period of the Agreement and for not less than four (4) years after termination/ completion of the Agreement.

---

3. Employer's Liability. If required by law, CONSULTANT and all subcontractors shall, for the benefit of their employees, provide, carry, maintain and pay for Employer's Liability Insurance in the minimum amount of One Hundred Thousand Dollars (\$100,000.00) per employee, Five Hundred Thousand Dollars (\$500,000) per aggregate.

4. Policies: Whenever, under the provisions of this Agreement, insurance is required of the CONSULTANT, the CONSULTANT shall promptly provide the following:

- (a) Certificates of Insurance evidencing the required coverage;
- (b) Names and addresses of companies providing coverage;
- (c) Effective and expiration dates of policies; and
- (d) A provision in all policies affording CITY thirty (30) days written notice by a carrier of any cancellation or material change in any policy.

5. Insurance Cancellation or Modification. Should any of the required insurance policies be canceled before the expiration date, or modified or substantially modified, the issuing company shall provide thirty (30) days written notice to the CITY.

6. Waiver of Subrogation. CONSULTANT hereby waives any and all right of subrogation against the CITY, its officers, employees and agents for each required policy. When required by the insurer, or should a policy condition not permit an insured to enter into a pre-loss agreement to waive subrogation without an endorsement, then CONSULTANT shall notify the insurer and request the policy be endorsed with a Waiver of Transfer of Rights of Recovery Against Others, or its equivalent. This Waiver of Subrogation requirement shall not apply to any policy which includes a condition to the policy not specifically prohibiting such an endorsement, or voids coverage should CONSULTANT enter into such an agreement on a pre-loss basis.

