



City of Pompano Beach

100 West Atlantic Blvd.
Pompano Beach, FL 33060

Detailed Minutes - Final

City Commission

Rex Hardin, Mayor

Beverly Perkins, Vice Mayor

Rhonda Eaton, Commissioner

Cyndy Floyd, Commissioner

Andrea McGee, Commissioner

Tom McMahon, Commissioner

Gregory P. Harrison, City Manager

Mark Berman, City Attorney

Asceleta Hammond, City Clerk

Tuesday, June 22, 2021

6:00 PM

Commission Chamber

City Commission Meeting

CALL TO ORDER

The Honorable Rex Hardin, Mayor called the Regular City Commission meeting to order at 6:05 p.m.

ROLL CALL

Present: Commissioner Rhonda Eaton
Commissioner Cyndy Floyd
Commissioner Andrea McGee
Commissioner Tom McMahon
Vice Mayor Beverly Perkins
Mayor Rex Hardin

INVOCATION

Bishop Charles Ross of Judah NOW Church offered the Invocation

PLEDGE OF ALLEGIANCE

Led by Asceleta Hammond, City Clerk.

APPROVAL OF MINUTES

[21-637](#) Special Virtual City Commission Meeting Minutes of June 1, 2021

A motion was made by Vice Mayor Perkins, seconded by Commissioner McGee, that the Minutes be APPROVED AS SUBMITTED. The motion carried unanimously.

21-636 City Commission Meeting Minutes of June 8, 2021

A motion was made by Vice Mayor Perkins, seconded by Commissioner McGee, that the Minutes be APPROVED AS SUBMITTED. The motion carried unanimously.

APPROVAL OF AGENDA

Mayor Hardin announced that Item 18 will be stricken from the Agenda.

A motion was made by Vice Mayor Perkins, seconded by Commissioner McGee, that the be APPROVED AS AMENDED. The motion carried unanimously.

CONSENT AGENDA DISCUSSION

The Commission may pull items from the Consent Agenda. During Audience to be Heard, a person may speak on any item on the Consent Agenda, which has not been pulled.

Mayor Hardin announced that Item 3 would be pulled for City Commission discussion.

A. SPECIAL PRESENTATION21-596 **Unity in the Community 2021 Scholarship Awards Presentation**

Mayor Rex Hardin and Mike Blangor, President of Unity in the Community of Pompano Beach, presented Rev. William Clark Memorial Scholarships to the following recipients:

<u>Student</u>	<u>High School</u>	<u>College / Major</u>
Gethsemane Henry-Bruce	Deerfield Beach HS	Broward College / Psychology
Ritchelle Pierre-Seide	Deerfield Beach HS	New College of Florida / Biology/Pre-Med
Ariana Roman	Deerfield Beach HS	Florida Gulf Coast University / Nursing
John Joseph Miller	Cardinal Gibbons HS	Florida Atlantic University / General Studies
Trinity Johnson	Blanche Ely HS	University of Pittsburgh / Biology/Pre-Med
Sedrian Jean	Blanche Ely HS	Florida International University / Business Mgmt.

Mike Blangor, President of Unity in the Community, stated this is their 10th Year of celebration and they have given out approximately \$50,000.00 in scholarships, which have been awarded to all Pompano Beach residents' students. Last year was a difficult year to present the scholarships but they did give out 8 scholarships and 6 will be given out for this year. Each student will receive a \$1,000 scholarship. Mr. Blangor thanked the residents, and the City Commission for all their help to make this presentation possible.

Mayor Hardin thanked everyone who have participated in the Unity in the Community event.

The Special Presentation was READ AND PRESENTED INTO THE RECORD.

21-647 Solid Waste and Recycling Scholarship Awards Presentation

Presentation of Solid Waste and Recycling scholarships to select college bound students from Pompano Beach High Schools was made by Russell Ketchem, Director of Solid Waste Services and Mayor Rex Hardin.

Scholarship Recipients:

<u>Student</u>	<u>College</u>
Alexander Cedeno	Florida Atlantic University
Janise Espers	Florida A & M
Kylie Frantello	Florida State University
Amari Freeman	Florida A & M
Sedrian Jean	Florida International University
Jomel Mompas	Alderson Broaddus University (WV)
Gabrielle Rose	Wellesley College

Russell Ketchem, Director of Solid Waste Services, stated that the scholarships being presented this year is part of a tradition that has been done with Waste Management for a number of years. It was part of the contract negotiations. These scholarships are offered to college bound high school students. Their focus must be of an environmental nature.

Beth Debow, Recycling Coordinator introduced the recipients for this year's scholarships.

The Special Presentation was READ AND PRESENTED INTO THE RECORD.

B. PROCLAMATIONS

21-565 Parks and Recreation Month

Mayor Rex Hardin proclaimed July as Parks and Recreation Month in the City of Pompano Beach. Mark Beaudreau, Recreation Programs Administrator, accepted the proclamation.

Mark Beaudreau, Recreations Program Administrator, mentioned that Earl Bosworth, Assistant City Manager is a true Parks and Recreation advocate, Greg Harrison, City Manager, was adamant in keeping the Parks opened during the pandemic time. Hence the City of Pompano Beach was one of a few cities throughout Broward County that kept the parks opened. He is truly amazed at the leadership that is always fighting for the

residents and employees, and it is greatly appreciated from everyone.

Continuing Mr. Beaudreau announced that coming up on June 25, the Moonlight Movies in the Community Park; June 26, from 4:00 p.m. to 8:00 p.m. Jazz in the Park at Hunter's Manor Park; July 8, National Freezer Pop Day; July 9, National Sugar Cookie Day; July 11, Take a Photo with Your Dog Day; July 15, National Tent Fire Safety Day; July 21, National Hot Dog Day; July 24, National Vanilla Ice Cream Day; and July 26, National Bagel Fest Day. He invited everyone to come out on these days and enjoy. Mr. Beaudreau stated that the Tennis Center, Golf Facility and the Aquatic Facility were opened as soon as possible and there was record breaking attendance, so all these people of the Recreation Department did a fantastic job during this pandemic time.

This matter was READ AND PRESENTED INTO THE RECORD

C. AUDIENCE TO BE HEARD

All persons interested in speaking during "Audience To Be Heard" must fill out a request form and turn it in to the City Clerk prior to the meeting. A request form is located on the last page of the agenda program.

Pursuant to Section 30.07(C)(2)(c) of the City's Code of Ordinances, "Thirty minutes or such time needed to permit ten members of the public to speak, whichever is less, shall be set aside at the beginning of each City Commission meeting for the "audience to be heard" session. The "audience to be heard" session shall be continued at the end of the Commission (Regular Agenda) meeting in the event that individuals wishing to speak are not reached during the first session". (Effective May 28, 2019)

The following persons spoke:

Financial Assistance to School children in Pompano Beach - Vicente Thrower, 1890 NW 6 Avenue, Pompano Beach, FL, stated that kids are getting ready to return to school after the pandemic, and they are one of the important members of the community. However, their parents have already gone through their savings and everything else they may have and will not be able to get them ready for back-to-school. Therefore, he is requesting that the City Commission ask the Management team to put together a small task force to see how a good successful back-to-school situation can be achieved. In sum, he said many parents do not have the money to purchase uniforms for the kids going back to school. So, perhaps the City could exercise some fiduciary responsibility and assist in this endeavor. This should not be passed on to another non-profit agency to handle. These would be for both Elementary and High School students in each District.

Continuing Services Contract Internship - Mr. Thrower mentioned that it would be good to have some of these scholarship recipients to return to the City and partner with those Continuing Services Contract in Engineering and other professional programs to turn into internship programs during the summer. The City used to have a Work Force Program that everyone used to participate in. Therefore, he asked why something similar to this program could not be put into some type of contract or solicitation when it is put out for bid, and ask people what would be their commitment to give back for a community benefit program. It would help to

put this into the solicitation for architects and engineers, because the kids go to school and do not come back because there is nothing available for them.

Casino Help - Mr. Thrower said the Casino has been in the City for years and they have not done anything in the Northwest Community. He mentioned that casinos in cities such as Hallandale Beach and Coconut Creek do things for their communities. Therefore, the City should look at how they can hold the Isle Casino accountable to do more in the communities.

Sign on NE 14th Street Causeway - Mike Skversky, 1630 SW 5 Avenue, Pompano Beach, FL, stated that he agreed with Mr. Thrower's point on the Casino assisting more in the community. He said a few people have complained to him about a large real estate sign on NE 14th Street Causeway. This sticks out like a sore thumb. This sign is not necessary as people are heading east to the beach, as well as for that kind of neighborhood that type of sign is out of place.

Dixie Highway Project - Mr. Skversky stated that he could not speak about the Dixie Highway project, but he wanted to know at the left hand turn how many seconds would the increase be - would it be for 5 or 10 seconds.

Additionally, Mr. Skversky asked with the Dixie Highway project, since there will be a lot done on the road and cones will be put up, will there be cones put up in all the areas so they will see what the traffic will look like, and how long will the cones be kept up.

Mayor Hardin is unsure how long the cones will be kept up, but he mentioned that there will be patterns to see what the traffic will be like. He suggested that Mr. Skversky contact Horacio Danovich via email, and he would be able to provide the facts and numbers on this.

Common Sense Planning - Tom Drum, 2700 NE 8 Street, Pompano Beach, FL, stated that over the past year, he thinks the City is lacking insight and common sense. He indicated that on Dixie Highway there are at least two multi-family housing units, yet the City is approving narrowing the roads from three lanes to two. How can you increase something and take it away for the "beauty of it?" This makes no sense to him. However, according to the plan, the City will allow 5,000 more units directly on Atlantic Boulevard and within a half mile of it and will be narrowed from three lanes to two. He suggested a test run be planned and should be done only during season to get an honest opinion of what is going to happen. Also, Brightline train has to be fully operational while this test is going because it affects the light changes sometimes by two different cycles. The City should get two different traffic study on this. He complained that the Circuit Shuttle, while it is cute and taking people around, it is not the mass transit that this amount of development needs. The City should have better transportation in place before it allowed all the building to take place.

Improvements in Pompano Beach - George Dillard, 801 NE 33 Street, Pompano Beach, FL, stated that he is happy to see the things that are going on with the Mitchell Moore Park, as well as the McNair Park in Collier City. He hopes this can keep going. He is proud of the City, and what the City Manager and the Mayor are doing.

Crime in the City - Mr. Dillard provided a brief history on his participation with the Youth in Action Club that

E. Pat Larkins started years ago. He is hoping a group of people can get something similar to this club started to keep the youth away from guns. Also, it could stop the black on black crime from getting started. His motto is "Hearts and minds up, guns down." The City is looking good now, and he desires for it to keep growing. He urged all residents of the City of Pompano Beach to stick together for the common good and growth of the City.

Finally, Mr. Dillard complained about the trash situation that continues to be seen within the community.

Sun Sentinel Article - Pat Russel Anderson, 2650 NE 24 Street, Pompano Beach, FL, stated that it is nice to see the Commission and that they look much better than through the Zoom meetings, which she is unaware on how to navigate the Zoom process. She related some information that she received about a Supreme Court ruling regarding public records rights in Florida. The Sun Sentinel Opinion dated June 15, 2021 carried the article on this subject, which she relayed her understanding of this matter to the Commission. She mentioned that all her emails are from public records and most released by requests to Asceleta Hammond, City Clerk with whom she has had very satisfactory requests fulfilled with videos, transcripts and audios for her last three years of defending, unsatisfactory closure of building permits and selective code enforcement in her opinion. Therefore, these should be re-opened and re-analyzed.

Right to Speak - Ray Burrows, 210 NE 3rd Street, Pompano Beach FL, spoke on behalf of Michael Grasso, NE 3 Street, Pompano Beach, FL. He said Mr. Grasso could not attend due to other obligations and asked him to read the following on his behalf:

"On June 1, 2021, a call to the Pompano Beach Special City Commission meeting, although I was present and acknowledged, I was muted on the facilitator's end, and not allowed to speak. I represent one of many people who were positively impacted by the Christ Church Love in Action ministry and are citizens of this community. I went through great measures to take part in the June 1 meeting because I do not have an email address. Signing up to speak at the June 1 meeting, I was asked for an email address and a phone number. Without these two I would not have been able to register, and this alone speaks to why many of the people who would like to speak about this issue, cannot. By placing the burdens of having an active cell phone, and an active email address on citizens of this community, you have unnecessarily encumbered citizens' right to speak at this forum. Therefore, I ask that you as representatives of this community rescind your vote and allow the will of the community be heard properly. Thank you and God bless."

Continuing, Mr. Burrows indicated that he has documents that show that he was on the call and submitted this to the City Clerk.

Correction to the Record for June 1, 2021 Virtual Special City Commission meeting - E. Wegman, NE 11 Avenue, Pompano Beach, FL, stated that she would like to correct the record from the last meeting. She stated that she does not like it implied that she came to speak falsehoods to the Commission. She said, "We might disagree on how we come down with the final facts. She then related when she watched the video and when Mayor Hardin stated that they were now under Reports, at which time City Manager Harrison provided comments on correcting the record about the statements made about his office sending the wrong information to Ms. Brown on the morning of June 1, 2021. She then provided a hard copy of the printout of the email sent out by Ms. Brown.

In sum, Ms. Wegman stated that a few persons were disenfranchised to speak at the June 1, 2021 Special City Commission meeting and requested that the City Commission rescind the item heard at that meeting.

June 1, 2021, Virtual Special City Commission meeting - Jorge Ruiz, 122 NE 10 Street, Pompano Beach, FL, stated that the Zoom meeting that the previous speaker Ms. Wegman was referring to, he was present for it and he was heard. However, he did not believe he was really heard. He stated that the City should notify the citizens of what is being done. He alleged that the Commission is trying to cut out four churches in the vicinity near City Hall. He asked that the City do not take out the churches as the Community needs the churches. He said he was made aware of the sale of the four churches and he tried to intercede, which was not effective. He reiterated that the City should contact the people of the community to inform them of what is taken place so they could be heard. He believes that the City has conducted business too fast especially during the time that the City was closed due to the pandemic.

In sum, he agrees with Ms. Wegman that the City Commission reopen the item of June 1, 2021, and notify everybody who lives in the City of Pompano Beach to speak about how they feel about losing four active churches. He said that perhaps the City should try to improve the existing schools instead of trying to purchase land for another school. He reiterated that the City Commission should redo the meeting of June 1, 2021 to hear those who want to voice their opinion.

Mayor Hardin enquired from the City Attorney about the purchase of the church property that the prior three speakers were referring to that took place without proper notice to the residents.

Mark Berman, City Attorney, responded no, and mentioned that the proper notice was done, the item was posted on the City's website, which is above and beyond what the law requires because of the closure of City Hall at the time. It was also posted out on the doors of City Hall.

Mayor Hardin noted that with the church property, the City did not take the property. The church property was being sold by the church. The City of Pompano Beach purchased the property. Actually, there were other people who were interested in purchasing the property.

D. CONSENT AGENDA

Mayor Hardin requested a motion to Approve/Adopt Items 1-2, and 4-5, without City Commission discussion.

A motion was made by Vice Mayor Perkins, seconded by Commissioner McGee, that the Consent Agenda be APPROVED/ADOPTED. The motion carried unanimously.

1. [21-599](#) A RESOLUTION OF THE CITY COMMISSION OF THE CITY OF POMPANO BEACH, FLORIDA, APPOINTING EUGENE M. STEINFELD AS SPECIAL MAGISTRATE TO PRESIDE OVER CODE ENFORCEMENT PROCEEDINGS OF THE

CITY OF POMPANO BEACH FOR A TWO-YEAR TERM; SAID TERM TO EXPIRE DECEMBER 7, 2022; PROVIDING AN EFFECTIVE DATE.

(Fiscal Impact: \$130.00 per hour)

(Staff Contact: Mark E. Berman)

A motion was made by Vice Mayor Perkins, seconded by Commissioner McGee, to APPROVE/ADOPT the item under the Consent Agenda. The motion carried unanimously.

Enactment No: RES. No. 2021-214

2. [21-610](#) A RESOLUTION OF THE CITY COMMISSION OF THE CITY OF POMPANO BEACH, FLORIDA, APPROVING AND AUTHORIZING THE PROPER CITY OFFICIALS TO EXECUTE A SERVICE CONTRACT BETWEEN THE CITY OF POMPANO BEACH AND ODYSSEY MANUFACTURING COMPANY, TO PROVIDE PLANNED AND EMERGENCY REPAIRS, REHABILITATION, MODIFICATION, MAINTENANCE, REPLACEMENT, NEW PURCHASES AND INSTALLATIONS FOR CHEMICAL FEED SYSTEMS AT CITY WATER TREATMENT AND REUSE PLANTS; PROVIDING AN EFFECTIVE DATE.

(Fiscal Impact: As needed basis not to exceed \$450,000 annually)

(Staff Contact: A. Randolph Brown)

A motion was made by Vice Mayor Perkins, seconded by Commissioner McGee, to APPROVE/ADOPT the item under the Consent Agenda. The motion carried unanimously.

Enactment No: RES. No. 2021-215

3. [21-597](#) A RESOLUTION OF THE CITY COMMISSION OF THE CITY OF POMPANO BEACH, FLORIDA, APPROVING AND AUTHORIZING THE PROPER CITY OFFICIALS TO EXECUTE AMENDMENT NO. 01 TO THE ALTERNATIVE WATER SUPPLY FUNDING PROGRAM AGREEMENT BETWEEN THE CITY OF POMPANO BEACH AND SOUTH FLORIDA WATER MANAGEMENT DISTRICT RELATING TO THE RECLAIMED WATER SYSTEM EXPANSION: NE 16TH STREET TO NE 24TH STREET AND NE 23RD AVENUE TO THE INTRACOASTAL WATERWAY; PROVIDING AN EFFECTIVE DATE.

(Fiscal Impact: Grant Revenue \$500,000)

(Staff Contact: A. Randolph Brown)

Comr. Eaton pulled the item for City Commission discussion, and stated that it is good that the City is obtaining this grant to expand the City's reclaimed water system. She indicated that it is imperative that they start to do outreach to the community to inform them of the reclaimed water, and how much the Utilities Department have refined and perfected this water, as well as the program for hookups, and encourage people to do it. She indicated that now that she is appointed to the Broward County Water Advisory Board, she has learnt so

much. The bottom line is that the use of reclaimed water for lawns and so forth really helps to replenish the City's Eastern wells, and prevent salt water intrusion. Once the wells get contaminated with salt water they are no longer usable. She wanted to emphasize that the City do a full view on communicating with the residents and how they can benefit themselves with the savings, and the use of reclaimed water, as well as how they are actually contributing to long term help of the City's water supply.

A. Randolph Brown, Utilities Director confirmed that the reuse water is not mandatory in the City of Pompano Beach.

In sum, Comr. Eaton stated that she felt that the City should do a really good public relations campaign to get the word out so people can understand the importance of reuse water and what it does for the water supply for future use.

Mr. Brown stated that the City has an award-winning Public Relations (PR) program and he plans to show this to the City Commission later on in the meeting. He indicated that they have a position that is dedicated to the reuse water, as well as the website is dedicated. Also, they are working on it on a daily basis. Mr. Brown reported to the public and those who have reuse irrigation, that this afternoon a contractor hit the City's 24-inch transmission reuse main and in order to make the repairs they had to shut the treatment plant down for tonight. The contractors are getting things ready and he hopes this will be a quick repair.

There was no public input on the item.

A motion was made by Vice Mayor Perkins, seconded by Commissioner McGee, that the Consent Agenda/ Resolution be ADOPTED. The motion carried by the following vote:

Yes: Eaton
Floyd
McGee
McMahon
Perkins
Hardin

Enactment No: RES. No. 2021-216

4. [21-570](#) A RESOLUTION OF THE CITY COMMISSION OF THE CITY OF POMPANO BEACH, FLORIDA, AMENDING RESOLUTION NO. 2008-189 WHICH GRANTED THE ALLOCATION OF SIX FLEXIBILITY UNITS FOR A PROPOSED TOWNHOUSE DEVELOPMENT ON THE HIGHLAND OAKS PLAT PB 179 PAGE 135B LOCATED AT 921 NW 3RD AVENUE; PROVIDING AN EFFECTIVE DATE.

(Fiscal Impact: N/A)

POSTPONED FROM JUNE 8, 2021

(Staff Contact: Jean Dolan/David Recor)

A motion was made by Vice Mayor Perkins, seconded by Commissioner McGee, that the Consent Agenda/ Resolution be ADOPTED.. The motion carried. by a unanimous voice vote.

Enactment No: RES. No. 2021-217

5. [21-635](#) A RESOLUTION OF THE CITY COMMISSION OF THE CITY OF POMPANO BEACH, FLORIDA, APPROVING AND AUTHORIZING THE PROPER CITY OFFICIALS TO EXECUTE A FUNDING AGREEMENT BETWEEN THE CITY OF POMPANO BEACH AND THE BROWARD COUNTY SHERIFF RELATING TO PARTICIPATION IN THE 2018 EDWARD BYRNE MEMORIAL JUSTICE ASSISTANCE GRANT PROGRAM; PROVIDING AN EFFECTIVE DATE.

(Fiscal Impact: \$58,553 funded by JAG Grant.)

(Staff Contact: Andrew Jean-Pierre)

A motion was made by Vice Mayor Perkins, seconded by Commissioner McGee, to APPROVE/ADOPT the item under the Consent Agenda. The motion carried unanimously.

Enactment No: RES. No. 2021-218

E. REGULAR AGENDA

QUASI-JUDICIAL PROCEEDING

Mark E. Berman, City Attorney, advised that Items 6 through 8 are listed under Quasi-Judicial Proceeding and are quasi-judicial in nature; therefore, anyone who wishes to testify must be sworn in and may be subject to cross-examination by the City Commission or any other interested party. The individuals addressing the City Commission must state his or her name, whether he or she has been sworn, and understands the rules which governs these proceedings. Thereafter, Mr. Berman outlined the order in which they would follow: City staff would make its presentation for each item, followed by the applicant or any other person(s) wishing to speak, closing argument, and the Commission's discussion.

Asceleta Hammond, City Clerk, placed under oath all individuals, including staff, addressing the City Commission in the following matters.

6. [21-562](#) **P.H. 2021-76: (PUBLIC HEARING 2ND READING)**
AN ORDINANCE OF THE CITY COMMISSION OF THE CITY OF POMPANO BEACH, FLORIDA, ABANDONING A TEN BY TEN FOOT UTILITY EASEMENT LOCATED AT FIRE STATION 52 ON THE SOUTHEAST CORNER OF SW 27TH AVENUE AND THE CANAL ADJACENT TO ATLANTIC BOULEVARD AND COMMONLY KNOWN AS 10 SW 27TH AVENUE; PROVIDING FOR

SEVERABILITY; PROVIDING AN EFFECTIVE DATE.
(Fiscal Impact: N/A)

FIRST READING: JUNE 8, 2021

(Staff Contact: Jean Dolan/David Recor)

Jean Dolan, Development Services Department, presented the item and stated this is the Second Reading of a City-initiated request to abandon a ten by ten-foot utility easement at Fire Station 52. There have been no changes since First Reading.

There was no public input on the item.

A motion was made by Vice Mayor Perkins, seconded by Commissioner McGee, that the Quasi-Judicial/ Ordinance be ADOPTED. The motion carried by the following vote:

Yes: Eaton
Floyd
McGee
McMahon
Perkins
Hardin

Enactment No: ORD. No. 2021-72

7. [21-568](#) **P.H. 2021-77: (PUBLIC HEARING 2ND READING)**

AN ORDINANCE OF THE CITY COMMISSION OF THE CITY OF POMPANO BEACH, FLORIDA, ABANDONING A REMNANT PORTION OF THE RIGHT-OF-WAY WITHIN THE PREVIOUSLY ABANDONED NW 6TH COURT RIGHT-OF-WAY LOCATED ADJACENT TO THE SONATA PROJECT ON THE WEST SIDE OF DIXIE HIGHWAY BETWEEN NW 6TH STREET AND NW 8TH COURT; PROVIDING FOR SEVERABILITY; PROVIDING AN EFFECTIVE DATE.
(Fiscal Impact: N/A)

FIRST READING: JUNE 8, 2021

(Staff Contact: Jean Dolan/David Recor)

Jean Dolan, Development Services Department, presented the item and stated this is the Second Reading of a request to abandon a remnant right-of-way within the Sonata project, left over from the 2008 abandonment of NW 6th Court. There have been no changes since the First Reading.

There was no public input for the item.

A motion was made by Vice Mayor Perkins, seconded by Commissioner McGee, that the Quasi-Judicial/ Ordinance be ADOPTED. The motion carried by the following vote:

Yes: Eaton
 Floyd
 McGee
 McMahan
 Perkins
 Hardin

Enactment No: ORD. No. 2021-73

8. [21-595](#) **P.H. 2021-80: (PUBLIC HEARING 1ST READING)**
 AN ORDINANCE OF THE CITY COMMISSION OF THE CITY OF POMPANO BEACH, FLORIDA, REZONING PROPERTY LYING ON THE SOUTHWEST CORNER OF N. OCEAN BLVD. AND NE 7TH COURT COMMONLY KNOWN AS 723 N. OCEAN BLVD. FROM RM-20 (MULTIPLE-FAMILY RESIDENCE 20) TO RPUD (RESIDENTIAL PLANNED UNIT DEVELOPMENT); PROVIDING FOR SEVERABILITY; PROVIDING AN EFFECTIVE DATE.
 (Fiscal Impact: N/A)
 (Staff Contact: Daniel Keester/David Recor)

Daniel Keester O'Mills, Principal Planner, Development Services Department, presented the item and stated that Robert Collins, a representative from Calvin Giordano Associates (CGA) will be making the presentation on behalf of staff for the rezoning application.

Robert Collins, CGA representative, stated the applicant is requesting City Commission's approval for a rezoning on a property located at 723 North Ocean Boulevard. The requested zoning change is from a RM-20 (Multiple-Family Residence 20) to RPUD (Residential Planned Unit Development). The subject property is 0.72 gross acres and consists of one parcel. The general location is the southwest corner of North Ocean Boulevard (A1A) and NE 7th Court. The associated site plan with the request is to demolish the existing structure on the site which is the previously used sales center for the Condominium building built across the street. The new proposal will construct a 12-unit, 3-story residential development with a density of 17 units per gross acre. The gross acres are used in the RPUD zoning as opposed to net density which is used in the RM-20 zoning. The application was approved by the Planning & Zoning Board on April 28, 2021. Associated with the zoning change, there are four (4) deviations that the applicant is requesting from the RPUD zoning regulations. The first is from front yard setback from 25 to 20 feet. The second is the pool location which is being requested in the front setback because of the lack of room in the rear setback and they are not permitted in the front setback. The third, there is a 5 acre minimum normally for the RPUD and the site is only .72 acres. The fourth is the applicant is requesting a density of 12-units per acre versus 9-units per acre with net density, which the RM-20 zoning regulations require. Staff found the zoning request to be in compliance.

Paola West, Land Planner, Plan West, LLC 10152 Indiantown Road, Unit 159, Jupiter, FL 33478, introduced the project architect, Gustavo Carbonell, along with the developer and representative for the owner, Joe Falso, all representing the Ocean 723 rezoning. Ms. West provided an overhead presentation of the location of the property, the size, the required right-of-way dedication, and the neighbors located to the north, south, west and east of the property. They are requesting a rezoning from RM-20 to RPUD designation that changes the map. There is a Master Plan that will guide the development. The Sabbia Beach Tower Condominium development was approved 3 units short of the maximum amount allowed, which does not affect the proposed project. However, she noted that the impact should be negligible since the project across the street was allowed to build 3 additional units. The proposed height will be 35 feet from grade. In addition, Ms. West requested a change from the PD document provided in the Commission backup, on page 18 there is a dimensional standard table 3. The table states a building height of 34 feet but they are requesting 35 feet, which is allowed by the RM-20. This minor change Exhibit was submitted to City staff.

Continuing, Ms. West indicated that they are proposing 12 units, however, 9 are allowed by code today, so, they are requesting to use the gross density, which goes to the center line of the road as opposed to the lot area, which is the requirement by zoning. The proposed development meets all of the RM-20 regulations except for 3, which Mr. Collins mentioned the density allowed for an RPUD request. Even though the maximum is 14-unit, they are requesting 12 units, as well as a request for a front back deviation of 20 versus the 25 required by code. Furthermore, a request to locate the pool amenity in the front of the building, which is closer to North Ocean Boulevard than opposed to the interior side, which is to the south or to the rear that is to the west. Finally, they are requesting that the City Commission waive the 5 acres minimum, which she provided the detailed justification on all of these deviations. Any questions on the architecture, the architect is available to respond.

Ms. West concluded that they had a neighborhood meeting on March 3, 2021 and they provided the summary to City staff on March 1, 2021. There was no negative information received from the neighbors. There were some questions from the neighbors regarding parking and whether this facility will be an Airbnb type organization, which the answer is no, as well as questions on staging of construction. Everyone was supportive of the project with no opposition.

Brian Ward, President of the Breakers HOA, 710 North Ocean Boulevard, Pompano Beach, who are neighbors to the proposed building, stated that they opposed the building and he was present for the Zoom meeting and there were at least 4 to 5 persons who opposed the project. He indicated their biggest concern is the parking and explained the impact this would have on their property and the surrounding areas. Their anticipation of construction debris negatively impacting their property will not be tolerated. Also, the traffic has become very busy and they are down to a two lane road, as well as the Marriott is building down the road from them will make things even tighter than before. In sum, they oppose the rezoning and urged the City Commission not to approve.

Comr. McGee stated that she notice the parking issue and inquired if they were doing 22 spaces where the requirement is 18.

Ms. West responded "that is correct."

Comr. McGee agrees with Mr. Ward that the current trend in which people live requires more parking spaces.

Hopefully, people will use alternative transportation or bikes or even walking, which is what the City is working on to alleviate congestion. Nevertheless, two cars per family is the reality. Therefore, Comr. McGee wanted to direct staff to look into what the City parking requirements are currently. She is concerned with providing parking especially on the beach, and to ensure that buildings are self-contained with their parking. Some of the older buildings currently do not have enough parking spaces for the units and rely on City parking spaces.

Additionally, Comr. McGee indicated that in the rendering provided by the developer, there was a small fence around the pool, and asked if a more substantial fence would be done. She mentioned that other condominiums in the area have complained of people jumping over the fences to use the pools, and hope this would be a problem they could avoid if they improved on the fencing. Also, she asked about the occupants of the proposed building not being able to access the beach through Sabbia Condominium, which Ms. West confirmed that they will not be able to do so.

Comr. McGee indicated that would be very disappointing to a buyer, so, perhaps they may want to reconsider implementing a club type membership. Finally, Comr. McGee asked if pets would be allowed in the building.

Ms. West indicated that yes they will be allowed.

Mayor Hardin inquired about the residents accessibility to the beach.

Ms. West mentioned that this matter came up for discussion at their public meeting and the only option is the public access that is a little north of the property and the other is a block south.

Mayor Hardin inquired about the parking, and did it exceed the requirement for the proposed 12 units.

Ms. West responded that is correct.

A motion was made by Vice Mayor Perkins, seconded by Commissioner McGee, that the Quasi-Judicial/ Ordinance be APPROVED FIRST READING. The motion carried by the following vote:

Yes: Eaton
Floyd
McGee
McMahon
Perkins
Hardin

END OF QUASI-JUDICIAL PROCEEDING

9. [21-646](#) A RESOLUTION OF THE CITY COMMISSION OF THE CITY OF POMPANO BEACH, FLORIDA, APPROVING AND AUTHORIZING THE PROPER CITY OFFICIALS TO EXECUTE A PROJECT COOPERATION AGREEMENT BETWEEN THE CITY OF POMPANO BEACH AND O.B. MITCHELL MOORE PARK, LLC AND TO TAKE ALL

ACTION CONSISTENT WITH SAID AGREEMENT; APPROVING THE RENAMING OF ATHLETIC FIELDS AT THE PARK; WAIVING COMPETITIVE BIDDING FOR THE PROJECT; PROVIDING AN EFFECTIVE DATE.

(Fiscal Impact: \$1,500,000.00)

(Staff Contact: Greg Harrison/Horacio Danovich)

Greg Harrison, City Manager, presented the item and stated that he is happy to report a great partnership between the City of Pompano Beach and Orange Bowl Committee. He mentioned that approximately 3 years ago, Henri Crockett came to his office and asked about the possibilities for the Orange Bowl Committee partnering with the City of Pompano Beach on enhancing the Mitchell Moore Park. Mr. Harrison announced that Mr. Crockett is a board member of the Orange Bowl Committee, proud to be from the City of Pompano Beach, FL, along with Eric Palms, CEO of the Orange Bowl Committee are attending the meeting. In addition, Mr. Harrison mentioned that they have been in contact off on frequently over the last three years. In fact, the Orange Bowl Committee has done something they have never done before, and that is to partner with a City and to allow the City to complete the contracts that were already started because of the G.O. Bond issue on the project. They are infusing \$1.5 million to the City's \$3 million already approved by the voters on the G.O. Bond issue. Horacio Danovich then provided a short presentation to explain the enhancements.

Horacio Danovich, G.O Bond and Innovation District Director, thanked Mr. Crockett and Mr. Palms for attending the meeting. He then highlighted what the charitable agreement entails. It is a \$1.5 million contribution. As a result of this contribution, some of these things will happen on the park. There will be a new press box in seating areas (bleachers), with shade upgrades to some of the bleachers. The team will refurbish two existing buildings with painting and little TLC. There will be an enhanced walking trail and a field maintenance program for the artificial turf. Moreover, there are some legal expenses and ribbon cutting ceremony that will be an event for everybody to attend. There is theming, and third party oversight, and contingency funds that are necessary when a project of this magnitude is done. Finally, there will be an enhanced scoreboard that will provide visibility from the I-95 highway.

Continuing Mr. Danovich presented an overhead presentation with a few highlighted areas, which is attached as **Exhibit 1**.

Mr. Harrison pointed out where the Orange Bowl logo will be placed on the scoreboard permanently along with the Mitchell Moore Park name on it, as well as their logo in the center of the football field. In addition, Mr. Harrison recognized Earl Bosworth, Assistant City Manager, Mark Beaudreau, Recreations Program Administrator, Scott Moore, Recreations Manager, and Pete McGinnis, Fire Marshal who assisted with information that the Orange Bowl Committee wanted the City to put together.

Mayor Hardin appreciated the work put in this project that has been "brewing for some time."

Eric Palms, CEO, Orange Bowl Committee, stated that this will be their 6th Legacy Gift project in South Florida, in the City of Pompano Beach, and the second in Broward County. This is a big year for them as they will be hosting the National Semi-finals on December 31, 2021, and looking forward that this partnership will come together within that window. They are honored to be participating with the City, and indicated that their

mission statement is to bring economic development to South Florida by virtue of giving back to the community in a meaningful way. He mentioned it has significant meaning to see players who come from neighborhoods, for example Henri Crockett played in the Orange Bowl in 1994, and for the Pompano Beach Ely High School that had so many players play in the Orange Bowl throughout the years. So, to go into this Mitchell Moore Park is very meaningful to the Orange Bowl and he thanked the City for its partnership and acknowledged City Manager Greg Harrison, and Horacio Danovich who have been working on this.

Henri Crockett, stated that he has walked through the City's streets and played in these parks. He recalls sitting in Vice Mayor Perkins' Office to talk for a long time about this, approximately three years ago. They talked about creating an atmosphere for families to come to the parks to watch their kids and have a good time and fellowship. Also, the importance of getting healthy and being able to turn the lights on at night and families walking around the park getting healthy and spending time with their kids. He is excited to see this come to fruition, and it has been a long road and a true partnership between the Orange Bowl and the City of Pompano Beach. He also thanked the City for the partnership and always supporting him and the Crockett Foundation.

Mr. Harrison mentioned he should have thanked Vice Mayor Perkins for her part in all of this.

Mayor Hardin thanked Mr. Crockett for all he has done for the City of Pompano Beach and indicated his help is much appreciated. This is just one more to a long line of activities that he has with the community, which is his hometown.

George Dillard, Pompano Beach, FL, stated he has known Mr. Crockett ever since he was a kid, playing football with the Chiefs a long time ago. He is proud of Mr. Crockett for everything he has done. He is happy that now they are accomplishing things in the northwest section of the City. He is happy they are keeping Mr. Carl Lee Jefferson at the Park, because he was his mentor and football coach who is an all around great man, who helped a number of kids. He thanked everybody who worked to get this partnership going, as well as Vice Mayor Perkins for all that she is doing. He encouraged everybody to keep up the good work.

Tundra King, 124 NW15th Street, Pompano Beach, FL, stated that she is super excited to see what is happening. She said a lot of the students that they serve at Morehead's Academy come from the area and they need to see the positive things going on in the community and built up in the northwest community. This will spark them to make changes and inspire them to come back like Mr. Crockett did to give back to the community. She asked if possible any funds left over to cover some of the bleachers.

Mr. Danovich responded that some will be covered. Also, the restrooms will be refurbished. He said there will be a new concession and bathroom buildings that were built as the function of the Mitchell Moore work done two years ago. The other building will be painted and fixed to get it ready for the event.

Ms. King asked about the limited parking for the park and if that would be addressed.

Mr. Danovich responded that the parking is being addressed on the north side of the field, which they will be trying to add more parking. The area is limited but they are trying to accommodate as much as they can with the G.O. Bond project.

Vicente Thrower, 1890 NW 6th Avenue, Pompano Beach, FL, stated that this is a terrific situation and appreciated the entire Crockett family. He inquired about the naming of the field, and will it still be Mitchell Moore Park. Also, he wanted to ensure they will be keeping the plaques and the trophy case.

Mark Berman, City Attorney, responded that it will be Orange Bowl Field at Mitchell Moore Park.

Mr. Thrower asked for covering for all the bleachers from the rain and the sun. Notwithstanding, this is a terrific opportunity. He thanked the Crockett family for their participation in this venture. He hopes they will have a successful Back to School event working along with the Crockett Foundation as they always do.

Mike Skversky, 1630 SW 5th Avenue, Pompano Beach, thinks this is a terrific idea, and encouraged the City Commission to go for it. He also inquired that perhaps they may want to put their logo up in some other parks.

Comr. McGee thinks this is an excellent idea and a “cool” partnership moving forward. She just want to ensure that the City secure a little space on the signage that will say, “Pompano Beach, Florida.”

Comr. Eaton thanked Mr. Crockett, Mr. Palms and the Orange Bowl Committee, as well as the City Manager and staff for making this a wonderful gift.

Comr. McMahon echoed the same sentiments as Comr. Eaton and thanked them for their partnership. He is looking forward to the improvements in the Park and expressed thanks to them for investing in the City.

Vice Mayor Perkins inquired if the G.O. Bond provided \$3 million for the Mitchell Moore Park.

Mr. Danovich responded that approximately \$2.9 million. He confirmed that these funds are being used for the park, but certain elements are being used through the funding the City is receiving from the Orange Bowl Committee, which will reduce the bill. This will not take away from the original funding.

Vice Mayor Perkins recalled sometime ago they were discussing the type of field they wanted and she mentioned about the Orange Bowl, but nobody did not know what she was referring to. She did not know this was “brewing” in her District. So, what she has some bother about, is that when something is going on in her District she would like to know ahead of time. She does not want to know about it when everybody else knows about it. She indicated that she has repeatedly mentioned this to the City Manager to inform her in advance if something is going to happen in her District. She was happy when she received a call from the City Manager that the City was getting these funds from the Orange Bowl, and is still happy, but she reiterated that she needs to be updated on everything in her district before it happens. Nevertheless, she is happy with the project and it is a plus that will bring a lot to the community.

Mayor Hardin thanked the entire Orange Bowl Committee and the Crockett family for all they have done. He stated this is a tremendous partnership between the Orange Bowl Committee and the City of Pompano Beach that does not happen every day. It is truly an honor to have them involved in the community, and Mr. Crockett throughout the years has done great work for the community. He thanked Mr. Harrison, Mr. Danovich and everyone else involved to make this happen. He is aware of all the requirements for discussion and the legalese involved.

A motion was made by Vice Mayor Perkins, seconded by Commissioner McGee, that the Regular Agenda/ Resolution be ADOPTED. The motion carried by the following vote:

Yes: Eaton
 Floyd
 McGee
 McMahan
 Perkins
 Hardin

Enactment No: RES. No. 2021-219

10. [21-454](#) A RESOLUTION OF THE CITY COMMISSION OF THE CITY OF POMPANO BEACH, FLORIDA, RESCINDING RESOLUTION NOS. 2003-38 AND 2020-113, AND APPROVING THE REVISED STREETS, PARK AND FACILITY NAMING AND DUAL-NAMING PROCEDURES AND CRITERIA FOR THE CITY OF POMPANO BEACH; PROVIDING AN EFFECTIVE DATE.
 (Fiscal Impact: N/A)

POSTPONED FROM APRIL 27, 2021 & MAY 25, 2021

(Staff Contact: Robert McCaughan/Mark Beaudreau)

Robert McCaughan, Director, Public Works Department, presented the item and stated the proposed policy to rename facilities, parks and streets has come before the Commission a few times for review. Staff has incorporated the comments provided. The first time the Commission asked for a segment of the street to be renamed versus the entire street, which has been accommodated. Also, to involve the Pompano Beach Historical Society in the review of the applications, which has been included in the policy. At the last meeting the Commission asked to have some leeway to make special consideration, which they can do. However, a current example, is the renaming of the Orange Bowl field at Mitchell Moore Park. So, clearly more will happen in the future and the Commission will have the leeway to do that. However, working with the City Attorney they have added item 11 to the criteria, which he read in its entirety.

“The Mayor and City Commission are authorized to approve naming of all City facilities after any persons, deceased or living, upon a determination that exceptional circumstances exist as justification for such action.” This will give the leeway to the City Commission for whatever the criteria is in the policy to approve those requesting renaming.

Vicente Thrower, 1890 NW 6th Avenue, Pompano Beach, FL, stated he is pleased to hear what the last amendment was because he wants to ensure the City Commission has the final say to rename streets, facilities and parks. He concluded that for issues that are germane to historical facts of the other side of the City and former friend Hazel Armbrister who had the Rock Road Group. In sum, he mentioned that the Commission do

not want to make one board the beginning and end to what is factual and what should be named. He would like to get residents such as Woodrow Wilson's name in the renaming process, as well as some of the others who have passed away last year. He then asked about the cost of doing this.

Mayor Hardin stated that the price would incorporate whatever the actual cost would be for signage. For example, if somebody would want to name a long street there will be a lot of signage so it would cost a bit more than \$500.

Mr. McCaughan responded that is correct. He explained that for facilities those signs that are in the front of the building are more expensive. Therefore, it is the cost of the signage that will be paid for.

He said the fathers and mothers of the City such as Woodrow Wilson and Dorothy Jones have paid their share amount of taxes and have contributed greatly to the City. Therefore, it should not involve additional fees outside the \$500, if persons such as these are nominated for renaming a facility, park or street after them.

Vice Mayor Perkins stated that she is still unsure who makes up the Historical Board and is concerned that this Board will make decisions on renaming, especially when these are names of people they may not know or may never heard about as residents.

Mr. McCaughan indicated that he is unaware of who makes up the membership of that Board. He confirmed that members of the Board do not make any decision, but rather they would make recommendations to the City Commission.

Comr. McMahon understands that the Board will only be providing a background of the person and not necessarily make a final decision on who is selected.

Vice Mayor Perkins inquired about how a person could join this Board.

Comr. McMahon responded that any resident from the community could become a member of the Board by just joining. There are no fees involved.

Mark Berman, City Attorney, clarified that just as item 11 was added for the renaming of the facilities, final decision for streets renaming remains with the City Commission. Everything else is recommendation and information. This is just some criteria being given to the Commission to consider setting some parameters so that they could focus on what is what and make that determination.

Mayor Hardin confirmed that no matter what anybody else may say it does come before the City Commission to make the final decision. Therefore, the Historical Committee will do information gathering and even if they make a recommendation, it is up to the City Commission to make the final decision.

A motion was made by Vice Mayor Perkins, seconded by Commissioner McGee, that the Regular Agenda/ Resolution be ADOPTED. The motion carried by the following vote:

Yes: Eaton
Floyd
McGee
McMahon
Perkins
Hardin

Enactment No: RES. No. 2021-220

11. [21-645](#) A RESOLUTION OF THE CITY COMMISSION OF THE CITY OF POMPANO BEACH, FLORIDA, APPROVING AND AUTHORIZING THE PROPER CITY OFFICIALS TO EXECUTE FOUR (4) LED LIGHTING AGREEMENTS WITH A TOTAL CITY CONTRIBUTION OF \$463,916.78 BETWEEN THE CITY OF POMPANO BEACH AND FLORIDA POWER & LIGHT COMPANY, FOR LIGHTING INSTALLATIONS OR IMPROVEMENTS IN THE LEISUREVILLE AREA; PROVIDING AN EFFECTIVE DATE.

(Fiscal Impact: \$463,916.78)

(Staff Contact: Horacio Danovich)

Horacio Danovich, G.O. Bond & Innovation District Director, presented the item and stated it is another one of these agenda items that pertains to more light conversion projects within the City. This is one that staff has been working on the design, and is ready to go. This is for the areas of Cresthaven, Leisureville, and Kendall Green. The design as well as FP&L is ready, so the next step is to pay the check for approximately \$463,916.78. This is important and so he urged the City Commission to approve it. He stated the next one would be for the Highlands area.

Mayor Hardin mentioned that this is on the minds of the public as there were questions about this during the last election.

There was no public input on the item.

Comr. Eaton stated this was a great investment in the Community, which will payoff, it will improve the quality of life, the streets, the safety for pedestrians, dog walkers and the kids. This will light up everything and will go a long way to reducing crime as well. Therefore, she is thrilled and she is aware of the huge amount of work done on the part of the City Manager and staff. She thanked everyone for this and is excited to see this coming to fruition. She wanted to be notified when ground will be breaking so she can attend. In addition, Comr. Eaton mentioned that part of this is being paid for with the G.O. Bond.

Comr. McMahon stated that the areas that lights have been installed have made huge improvements and given the areas a whole new look and feel for the community and adding the security that was much needed in every part of the City. It is exciting and he is very much for projects like this one.

A motion was made by Vice Mayor Perkins, seconded by Commissioner McGee, that the Regular Agenda/ Resolution be ADOPTED. The motion carried by the following vote:

Yes: Eaton
Floyd
McGee
McMahon
Perkins
Hardin

Enactment No: RES. No. 2021-221

12. [21-566](#) **P.H. 2021-78: (PUBLIC HEARING 2ND READING)**

AN ORDINANCE OF THE CITY COMMISSION OF THE CITY OF POMPANO BEACH, FLORIDA, APPROVING AND AUTHORIZING THE PROPER CITY OFFICIALS TO EXECUTE A SERVICE CONTRACT BETWEEN THE CITY OF POMPANO BEACH AND THE BUTLER GROUP OF SOUTH FLORIDA, LLC TO PROVIDE SCHOOL CROSSING SERVICES; PROVIDING FOR SEVERABILITY; PROVIDING AN EFFECTIVE DATE.

(Fiscal Impact: FY 22 - \$782,292.00)

FIRST READING: JUNE 8, 2021

(Staff Contact: Scott Moore/Mark Beaudreau)

Mark Beaudreau, Recreation Programs Administrator, presented the item and stated that there are no changes to this item since First Reading.

There was no public input on the item.

A motion was made by Vice Mayor Perkins, seconded by Commissioner McGee, that the Regular Agenda/ Ordinance be ADOPTED. The motion carried by the following vote:

Yes: Eaton
Floyd
McGee
McMahon
Perkins
Hardin

Enactment No: ORD. No. 2021-74

13. [21-512](#) **P.H. 2021-70: (PUBLIC HEARING 2ND READING)**

AN ORDINANCE OF THE CITY COMMISSION OF THE CITY OF POMPANO BEACH, FLORIDA, AUTHORIZING, SUBJECT TO THE TERMS AND CONDITIONS HEREIN, THE ISSUANCE OF NOT TO EXCEED \$12,000,000 IN AGGREGATE PRINCIPAL AMOUNT OF THE CITY'S WATER AND WASTEWATER REVENUE BOND, SERIES 2021 FOR THE PRIMARY PURPOSE OF FINANCING THE ACQUISITION, CONSTRUCTION AND EQUIPPING OF PROJECTS RELATING TO THE CITY'S WATER AND WASTEWATER UTILITY SYSTEM; PROVIDING FOR THE ISSUANCE FROM TIME TO TIME OF WATER AND WASTEWATER REVENUE BONDS OR NOTES; PLEDGING CERTAIN NET REVENUES OF THE WATER AND WASTEWATER UTILITY SYSTEM FOR THE PAYMENT THEREOF; PROVIDING FOR THE RIGHTS OF THE HOLDERS THEREOF; PROVIDING FOR THE ISSUANCE OF BOND ANTICIPATION NOTES; MAKING OTHER COVENANTS AND AGREEMENTS IN CONNECTION THEREWITH; REPEALING OTHER INSTRUMENTS; PROVIDING AN EFFECTIVE DATE.

(Fiscal Impact: \$12,000,000)

FIRST READING: MAY 25, 2021

(Staff Contact: Andrew Jean-Pierre)

Andrew Jean-Pierre, Finance Director, presented the item and stated that with the approval of this and the next 3 items the City will be closing on the loan this Thursday, June 24, 2021. There are no further comments from the First Reading.

There was no public input on the item.

A motion was made by Vice Mayor Perkins, seconded by Commissioner McGee, that the Regular Agenda/ Ordinance be ADOPTED. The motion carried by the following vote:

Yes: Eaton
Floyd
McGee
McMahon
Perkins
Hardin

Enactment No: ORD. No. 2021-62

14. [21-513](#) **P.H. 2021-71: (PUBLIC HEARING 2ND READING)**

AN ORDINANCE OF THE CITY COMMISSION OF THE CITY OF POMPANO BEACH, FLORIDA, PROVIDING FOR THE ISSUANCE OF THE CITY OF POMPANO BEACH, FLORIDA, WATER AND WASTEWATER REVENUE BOND,

SERIES 2021 IN AN AGGREGATE PRINCIPAL AMOUNT OF NOT EXCEEDING \$12,000,000 UNDER ORDINANCE NO. 2021-62 ENACTED ON JUNE 22, 2021, FOR THE PURPOSE OF FINANCING, TOGETHER WITH OTHER LEGALLY AVAILABLE FUNDS OF THE ISSUER, THE ACQUISITION, CONSTRUCTION AND EQUIPPING OF ALL OR A PORTION OF CERTAIN CAPITAL PROJECTS RELATED TO THE ISSUER'S WATER AND WASTEWATER SYSTEM AND PAYING COSTS OF ISSUANCE OF THE SERIES 2021 BOND; FIXING CERTAIN TERMS AND DETAILS OF THE SERIES 2021 BOND; AUTHORIZING EXECUTION AND DELIVERY OF THE SERIES 2021 BOND; AUTHORIZING THE NEGOTIATED SALE OF THE SERIES 2021 BOND TO CENTERSTATE BANK, N.A.; DIRECTING THE APPLICATION OF THE PROCEEDS OF THE SERIES 2021 BOND; APPOINTING THE ISSUER AS THE INITIAL PAYING AGENT AND REGISTRAR FOR THE SERIES 2021 BOND; AUTHORIZING OTHER REQUIRED ACTIONS; PROVIDING FOR SEVERABILITY; PROVIDING AN EFFECTIVE DATE.

(Fiscal Impact: \$12,000,000)

FIRST READING: MAY 25, 2021

(Staff Contact: Andrew Jean-Pierre)

Andrew Jean-Pierre, Finance Director, presented the item and stated that there are no changes from the First Reading of this proposed Ordinance.

There was no public input on the item.

A motion was made by Vice Mayor Perkins, seconded by Commissioner McGee, that the Regular Agenda/ Ordinance be ADOPTED. The motion carried by the following vote:

Yes: Eaton
Floyd
McGee
McMahon
Perkins
Hardin

Enactment No: ORD. No. 2021-63

15. [21-514](#) **P.H. 2021-72: (PUBLIC HEARING 2ND READING)**

AN ORDINANCE OF THE CITY COMMISSION OF THE CITY OF POMPANO BEACH, FLORIDA, AUTHORIZING, SUBJECT TO THE TERMS AND CONDITIONS HEREIN, THE ISSUANCE OF NOT TO EXCEED \$11,000,000 IN AGGREGATE PRINCIPAL AMOUNT OF THE CITY'S STORMWATER UTILITY REVENUE BOND, SERIES 2021 FOR THE PRIMARY PURPOSE OF FINANCING THE ACQUISITION,

CONSTRUCTION AND EQUIPPING OF PROJECTS RELATING TO THE CITY'S STORMWATER UTILITY SYSTEM; PROVIDING FOR THE ISSUANCE FROM TIME TO TIME OF STORMWATER UTILITY REVENUE BONDS OR NOTES; PLEDGING CERTAIN NET REVENUES OF THE STORMWATER UTILITY SYSTEM FOR THE PAYMENT THEREOF; PROVIDING FOR THE RIGHTS OF THE HOLDERS THEREOF; PROVIDING FOR THE ISSUANCE OF BOND ANTICIPATION NOTES; MAKING OTHER COVENANTS AND AGREEMENTS IN CONNECTION THEREWITH; REPEALING OTHER INSTRUMENTS; PROVIDING AN EFFECTIVE DATE.

(Fiscal Impact: \$11,000,000)

FIRST READING: MAY 25, 2021

(Staff Contact: Andrew Jean-Pierre)

Andrew Jean-Pierre, Finance Director, presented the item and stated that there are no changes from the First Reading of this proposed Ordinance.

There was no public input on the item.

A motion was made by Vice Mayor Perkins, seconded by Commissioner McGee, that the Regular Agenda/ Ordinance be ADOPTED.. The motion carried by the following roll call vote:

Yes: Eaton
Floyd
McGee
McMahon
Perkins
Hardin

Enactment No: ORD. No. 2021-64

16. [21-515](#) **P.H. 2021-73: (PUBLIC HEARING 2ND READING)**

AN ORDINANCE OF THE CITY COMMISSION OF THE CITY OF POMPANO BEACH, FLORIDA, PROVIDING FOR THE ISSUANCE OF THE CITY OF POMPANO BEACH, FLORIDA STORMWATER UTILITY REVENUE BOND, SERIES 2021 IN AN AGGREGATE PRINCIPAL AMOUNT OF NOT EXCEEDING \$11,000,000 UNDER ORDINANCE NO. 2021-64 ENACTED ON JUNE 22, 2021, FOR THE PURPOSE OF FINANCING, TOGETHER WITH OTHER LEGALLY AVAILABLE FUNDS OF THE ISSUER, THE ACQUISITION, CONTRUCTION AND EQUIPPING OF ALL OR A PORTION OF CERTAIN CAPITAL PROJECTS RELATED TO THE ISSUER'S STORMWATER UTILITY SYSTEM AND PAYING COSTS OF ISSUANCE OF THE SERIES 2021 BOND; FIXING CERTAIN TERMS AND DETAILS OF THE

SERIES 2021 BOND; AUTHORIZING EXECUTION AND DELIVERY OF THE SERIES 2021 BOND; AUTHORIZING THE NEGOTIATED SALE OF THE SERIES 2021 BOND TO CENTERSTATE BANK, N.A.; DIRECTING THE APPLICATION OF THE PROCEEDS OF THE SERIES 2021 BOND; APPOINTING THE ISSUER AS THE INITIAL PAYING AGENT AND REGISTRAR FOR THE SERIES 2021 BOND; AUTHORIZING OTHER REQUIRED ACTIONS; PROVIDING FOR SEVERABILITY; PROVIDING AN EFFECTIVE DATE.

(Fiscal Impact: \$11,000,000)

FIRST READING: MAY 25, 2021

(Staff Contact: Andrew Jean-Pierre)

Andrew Jean-Pierre, Finance Director, presented the item and stated that there are no changes from the First Reading of this proposed Ordinance.

There was no public input on the item.

A motion was made by Vice Mayor Perkins that the Regular Agenda/ Ordinance be ADOPTED. The motion carried by the following vote:

Yes: Eaton
Floyd
McGee
McMahon
Perkins
Hardin

Enactment No: ORD. No. 2021-65

17. [21-608](#) **P.H. 2021-79: (PUBLIC HEARING 1ST READING)**

AN ORDINANCE OF THE CITY COMMISSION OF THE CITY OF POMPANO BEACH, FLORIDA, AMENDING CHAPTER 152, "BUILDINGS," BY AMENDING SECTION 152.06, "CONSTRUCTION DEBRIS MITIGATION AND SCREENING," TO MODIFY REQUIREMENTS AND CONDITIONS FOR TEMPORARY CONSTRUCTION FENCING; PROVIDING FOR SEVERABILITY; PROVIDING AN EFFECTIVE DATE.

(Fiscal Impact: N/A)

(Staff Contact: Jennifer Gomez/Michael Rada)

Jennifer Gomez, Assistant Director, Development Services Department, presented the item and stated that Michael Rada, Building Official has joined with her, and they will be talking about some proposed amendments for a temporary construction of fences. Currently, the City's construction fences requirement do not allow

signage of any graphics or description of the project itself. However, there has been a continued interest from the development community to be more creative with their construction fences. The demand is for the screening to be more visually appealing and informative. In addition to creating some new maintenance standards, which the proposed ordinance does, and it would allow temporary construction screening to include project contact information, project information renderings, City logos, City imagery, and any approved screening graphics from the City's marketing office, as well as some public art murals if they get approved by the City.

Continuing, Ms. Gomez indicated that as proposed, the Code Compliance division will be charged with enforcing the temporary construction standards. The Building Official will issue stop work orders if there are any public safety issues.

There was no public input on the item.

Comr. McGee stated that this is a great modification to the City's code. In fact, since the new panels went up around the McNab House, there has been a lot of excitement and people can see what is happening. Therefore, for both the City and private developers this is great to be able to communicate the upcoming events.

Comr. Eaton commented that this is long overdue.

Comr. McMahan commented that this is a much needed improvement and thanked staff for the hard work that went into designing this. He had brought this to staff's attention that these construction sites sometimes do not look so pleasing, and he has received a number of exciting phone calls on what is coming and what is happening. He thanked staff for their efforts.

City Manager Greg Harrison, acknowledged Michael Rada who was also attending the meeting regarding the item.

Mayor Hardin stated that this is a great modification and he hopes this will create a standard in the City of Pompano Beach that all the developers strive to beat each other on the best looking graphics on their signs. He thanked Mr. Rada for all he is doing for the City's Building Department. He stated he has received good compliments of him for this kind of stuff.

A motion was made by Vice Mayor Perkins, seconded by Commissioner McGee, that the Regular Agenda/ Ordinance be APPROVED FIRST READING. The motion carried by the following vote:

Yes: Eaton
Floyd
McGee
McMahon
Perkins
Hardin

18. [21-642](#) **P.H. 2021-81: (PUBLIC HEARING 1ST READING)**

AN ORDINANCE OF THE CITY COMMISSION OF THE CITY OF POMPANO BEACH, FLORIDA, AMENDING CHAPTER 34, "CITY POLICY," OF THE CITY OF POMPANO BEACH CODE OF ORDINANCES RELATING TO THE POLICE AND FIREFIGHTERS' RETIREMENT SYSTEM, BY AMENDING SECTION 34.045, "DEFINITIONS," TO DEFINE SENIOR MANAGEMENT EMPLOYEES; BY AMENDING SECTION 34.053 "NORMAL RETIREMENT DATE", TO INCLUDE PROVISIONS APPLICABLE TO SENIOR MANAGEMENT EMPLOYEES; BY AMENDING SECTION 34.059, "ACCRUED BENEFITS" TO PROVIDE FOR SUCH BENEFITS FOR SENIOR MANAGEMENT EMPLOYEES; PROVIDING FOR SEVERABILITY; PROVIDING AN EFFECTIVE DATE

(Fiscal Impact: N/A)

(Staff Contact: Ed Beecher/Peter McGinnis)

A motion was made by Vice Mayor Perkins, seconded by Commissioner McGee, that the Regular Agenda/ Ordinance be STRICKEN. The motion carried by a unanimous voice vote.

19. [21-641](#) A RESOLUTION OF THE CITY COMMISSION OF THE CITY OF POMPANO BEACH, FLORIDA, APPROVING THE AMERICAN RESCUE PLAN ALLOCATION PLAN FOR THE CITY AND AUTHORIZING THE PROPER CITY OFFICIALS TO EXECUTE ALL DOCUMENTS RELATING TO THE PLAN AND THE CREATION OF AN AMERICAN RESCUE PLAN FUND AND AUTHORIZING EXPENDITURES FROM SAME; PROVIDING AN EFFECTIVE DATE.

(Fiscal Impact: Grant Revenue-\$25,844,057)

(Staff Contact: Suzette Sibble)

Suzette Sibble, Assistant City Manager, presented the item and stated the item is requesting City Commission's approval of the City's American Rescue Plan Act (ARPA) allocation plan. There is a detailed spreadsheet that was provided in the backup material that outlines some of the recommended programs and line item expenditures that are recommended to be funded with ARPA funds. Also, she presented a Powerpoint presentation which is attached as **Exhibit 2**, that explains what the ARPA is all about and the subsequent proposed Resolution.

Ms. Sibble indicated that the ARPA was signed by the President on March 11, 2021, which represents the third COVID-19 Federal Stimulus package that was passed by the federal government in an effort to provide economic recovery relief to various levels of government, as well as assistance to the communities, individuals and businesses within the communities. She said within ARPA, \$350 billion have been allocated to various levels of government. She then went in to detail on how these funds could be expended as indicated in Exhibit 2. The total allocation of ARPA funds to the City of Pompano Beach is \$25.7 million, which will be distributed into two equal installments. The first took place in May 2021, and the second will take place in May 2022. Consequently, staff is requesting the City Commission authorization to allow allocation to various line items.

There was no public input on the item.

Comr. McGee mentioned that it is great that the City is able to access so many programs and save on increase in the operating millage, and things of that nature. She stated that the only line item that has a “bad taste in my mouth” is the vaccination incentive program. The idea of bribing people to make a personal choice about their health care just does not sit well with her. She then explained the reason for her opinion. Therefore, she would want to make a motion to possibly change this item to having a \$100 gift card for Publix for those who can prove continued financial hardships due to COVID-19 but not tie it to a medical decision.

Comr. Eaton agreed with the fact that there are people suffering financially and have trouble trying to make ends meet, where the Publix gift card would be extremely helpful. However, she inquired if both programs could be done. So, if a person receives the vaccine he/she can receive \$100 Publix gift card, as well as if he/she can show due hardship then assistance could also be extended to this person.

Comr. McGee inquired about the percentage of fully vaccinated people currently, and asked if people who were already vaccinated will be given a gift card.

Ms. Sibble responded no.

Greg Harrison, City Manager, explained that currently the vaccines are administered by the Department of Health, that has a database of all Broward County residents who have received the first shot and some people have received two shots and the different types of vaccines. The people eligible for this will not be in the database that they currently have those already vaccinated. In sum, staff’s interpretation is to offer incentive to those who were not yet vaccinated and try to offer some type of incentive for this. However, what the Commission is suggesting to prove financial hardship will put a little more hardship on staff proving people’s financial statement. Nevertheless, what Comr. McGee mentioned about hardships do fit with other incentives on the ARPA list. For example, rent subsidies, the folks that cannot pay their water bill, which are already set up in the ARPA. Therefore, if the idea of the vaccine’s incentive is not liked then the City could carve out an amount from the \$3 million and add to the other categories that are already in place for helping people who are down and out.

Comr. McGee indicated if that is an easier way, she would amend her motion to make it happen. She was unaware of the logistics of handling this matter, but she did not want for the City to miss the opportunity to help people who need it. Therefore, she amended her motion to say, “Take the \$3.25 million and allow this into other categories where the City can help people based upon objective criteria, if they need the help.”

Comr. Eaton agreed with the amended motion. Also, she had heard that they are looking toward amending some of this legislation to allow cities to expand use of this funding. So, she likes the flexibility, but would still support the idea of offering \$100 gift certificate to who gets the vaccine, and still be able to help people with the important things such as rent, water bill and other hardships being experienced.

Mayor Hardin indicated that he is set against the motion as it is stated. He believes the City should incentivize people to go out and get vaccinated. Not only will it help them but it will help the general public. The cost of

health care is high and some of these people do not always have health insurance. In sum, anything that the City can do to assist people in getting vaccinated is worthwhile. However, he does not believe the City will spend the entire \$3.25 million for this. So, these things will be brought back to the City Commission for adjustments and to move certain items around. There are other ways included in this ARPA that can assist persons, but the incentive program for getting vaccinations he wholeheartedly agrees with. The medical evidence is clear that vaccinations save lives and the core job of government is public safety.

Vice Mayor Perkins indicated that she agrees with Mayor Hardin to issue the \$100 gift certificate, which is not a bribe but rather it is a contribution of saving lives. People are comfortable around those persons who received their vaccination and it would help to provide incentive to those who have not yet taken theirs.

Comr. Floyd mentioned that people with underlying issues do not have to get vaccinated, but other people who have not yet taken the shots, this may nudge them towards getting this. She supports helping people that need the help, but if this will assist those to go get vaccinated she likes the idea.

Mr. Harrison clarified that staff is asking the City Commission's authority to go into the proposed categories and move them around as reality hits, so this will not need to come back to the Commission for discussion at each meeting.

Comr. McGee clarified her views on the idea that it is everyone's personal decision, but as a governing body, the City is not medical doctors. With a new vaccine that has had side effects, and has had deaths, these are the ones she has an issue with the City incentivizing people, other than just providing the opportunity to assist people in overall hardships.

Mayor Hardin informed the public that the City endorses the shots, it supports the shots and encourages people to get the shots. There are individuals that do not agree with this and that is their own personal choice. However, as a governing body the City of Pompano Beach fully supports people to get vaccinated.

MOTION: A motion was made by Comr. McGee seconded by Comr. Eaton to take the \$3.25 million and allow this into other categories where the City can help people based upon objective criteria, if they need the help.

**No: Comr. Eaton
Comr. Floyd
Comr. McMahon
Vice Mayor Perkins
Mayor Hardin**

Yes: Comr. McGee

Continuing, with discussion on the original motion, Mayor Hardin inquired if the intent of the City Manager and Assistant City Manager is to have some flexibility so if this does not work they will try to come up with a better idea on how to get people vaccinated.

Mr. Harrison indicated that he is unsure if anything more can be done in this regard to incentivized the public to

take the vaccination. However, he clarified how the line items would work in the event they ran short in one category they could move funds into the more utilized category.

Mayor Hardin does not want to lose sight of the incentive to take the vaccine.

Ms. Sibble mentioned that the right states that the incentive has to be reasonable.

Mayor Hardin asked if the funds are flexible enough to assist children to get back to school assistance.

Mr. Harrison responded yes, but the Broward School District has the same funding that the City is getting for school related items.

Comr. Floyd inquired if the School Board funding could assist with uniforms and shoes for the kids.

The consensus is that the School Board would have to come up with their own list of classified items that they would want to spend their assigned funding on.

Mayor Hardin mentioned that he has been reading a lot about the PPP loans that went out earlier about how people who should not have received had received. The business assistance that the City makes available, there are tight guidelines on that, so people just do not get a blank check. They have to show proof that they really need it.

Ms. Sibble responded that is correct.

A motion was made by Vice Mayor Perkins, seconded by Commissioner McGee, that the Regular Agenda/ Resolution be ADOPTED. The motion carried by the following vote:

Yes: Eaton
Floyd
McGee
McMahon
Perkins
Hardin

Enactment No: RES. No. 2021-222

20. [21-578](#) A RESOLUTION OF THE CITY COMMISSION OF THE CITY OF POMPANO BEACH, FLORIDA, APPOINTING **W.P. DAVIS, JR.** TO THE AIR PARK ADVISORY BOARD OF THE CITY OF POMPANO BEACH AS ALTERNATE 1, FOR A TERM OF THREE (3) YEARS; SAID TERM TO EXPIRE ON JULY 1, 2024; PROVIDING AN EFFECTIVE DATE.
(Fiscal Impact: N/A)

APPLICANTS:

W.P. Davis, Jr. - District 1
 Richard Tobin - District 1
 Eve Lewis - District 3
 Frank Sellers, Jr. - District 3
 Dedrick Watkins - District 5

(Staff Contact: Asceleta Hammond)

A motion was made by Vice Mayor Perkins, seconded by Commissioner McGee, that the Regular Agenda/ Resolution be ADOPTED and to insert the name W.P. DAVIS, JR. Commissioner McGee nominated W.P. Davis, Jr. The motion carried unanimously.

Enactment No: RES. No. 2021-223

21. [21-579](#) A RESOLUTION OF THE CITY COMMISSION OF THE CITY OF POMPANO BEACH, FLORIDA, APPOINTING **RICHARD TOBIN** TO THE AIR PARK ADVISORY BOARD OF THE CITY OF POMPANO BEACH AS ALTERNATE 2, FOR A TERM OF THREE (3) YEARS; SAID TERM TO EXPIRE ON JULY 1, 2024; PROVIDING AN EFFECTIVE DATE.

(Fiscal Impact: N/A)

PLEASE REFER TO FILE ID NO 21-578 FOR APPLICANTS.

(Staff Contact: Asceleta Hammond)

A motion was made by Vice Mayor Perkins, seconded by Commissioner McGee, that the Regular Agenda/ Resolution be ADOPTED and to insert the name RICHARD TOBIN. Comr. McGee nominated Richard Tobin. The motion carried unanimously.

Enactment No: RES. No. 2021-224

22. [21-612](#) A RESOLUTION OF THE CITY COMMISSION OF THE CITY OF POMPANO BEACH, FLORIDA, APPOINTING **RICHARD J. PORRARO** TO THE GOLF ADVISORY BOARD OF THE CITY OF POMPANO BEACH FOR A TERM OF THREE (3) YEARS; SAID TERM TO EXPIRE ON MAY 8, 2024; PROVIDING AN EFFECTIVE DATE.

(Fiscal Impact: N/A)

APPLICANTS:

Gary S.Ruderman, Incumbent - District 1
 Patricia A. DeSanctis, Incumbent - District 1
 Richard J. Porraro, Incumbent - District 1
 James R. Bunn, Incumbent - District 3

Roger Gingerich, Alternate #1 - District 5
 Donald Totter, Alternate #2 - District 1
 Carlton Gillespie- District 1
 Mary Beth McCabe - District 1
 Corey Staniscia - District 1
 Eve Lewis - District 3
 Frank Sellers, Jr. - District 3
 Charles MacMichael- District 5

(Staff Contact: Asceleta Hammond.)

A motion was made by Vice Mayor Perkins, seconded by Commissioner McGee, that the Regular Agenda/ Resolution be ADOPTED and to insert the name RICHARD J. PORRARO. Mayor Hardin nominated Richard J. Porraro. The motion carried unanimously.

Enactment No: RES. No. 2021-225

23. [21-616](#) A RESOLUTION OF THE CITY COMMISSION OF THE CITY OF POMPANO BEACH, FLORIDA, APPOINTING GARY S. RUDERMAN TO THE GOLF ADVISORY BOARD OF THE CITY OF POMPANO BEACH FOR A TERM OF THREE (3) YEARS; SAID TERM TO EXPIRE MAY 8, 2024; PROVIDING AN EFFECTIVE DATE.

(Fiscal Impact: N/A)

PLEASE REFER TO FILE ID NO 2021-612 FOR APPLICANTS.

(Staff Contact: Asceleta Hammond)

A motion was made by Vice Mayor Perkins, seconded by Commissioner McGee, that the Regular Agenda/ Resolution be ADOPTED and to insert the name GARY S. RUDERMAN. Vice Mayor Perkins nominated Gary S. Ruderman. The motion carried unanimously.

Enactment No: RES. No. 2021-226

24. [21-617](#) A RESOLUTION OF THE CITY COMMISSION OF THE CITY OF POMPANO BEACH, FLORIDA, APPOINTING PATRICIA A. DESANCTIS TO THE GOLF ADVISORY BOARD OF THE CITY OF POMPANO BEACH FOR A TERM OF THREE (3) YEARS; SAID TERM TO EXPIRE MAY 8, 2024; PROVIDING AN EFFECTIVE DATE.

(Fiscal Impact: N/A)

PLEASE REFER TO FILE ID NO 2021-612 FOR APPLICANTS.

(Staff Contact: Asceleta Hammond)

A motion was made by Vice Mayor Perkins, seconded by Commissioner McGee, that the Regular Agenda/ Resolution be ADOPTED and to insert the name PATRICIA A. DESANCTIS. Commissioner McGee nominated Patricia A. DeSanctis. The motion carried unanimously.

Enactment No: RES. No. 2021-227

25. [21-618](#) A RESOLUTION OF THE CITY COMMISSION OF THE CITY OF POMPANO BEACH, FLORIDA, APPOINTING JAMES R. BUNN TO THE GOLF ADVISORY BOARD OF THE CITY OF POMPANO BEACH FOR A TERM OF THREE (3) YEARS; SAID TERM TO EXPIRE MAY 8, 2024; PROVIDING AN EFFECTIVE DATE.

(Fiscal Impact: N/A)

PLEASE REFER TO FILE ID NO 2021-612 FOR APPLICANTS.

(Staff Contact: Asceleta Hammond)

A motion was made by Vice Mayor Perkins, seconded by Commissioner McGee, that the Regular Agenda/ Resolution be ADOPTED and to insert the name JAMES R. BUNN. Mayor Hardin nominated James R. Bunn. The motion carried unanimously.

Enactment No: RES. No. 2021-228

26. [21-619](#) A RESOLUTION OF THE CITY COMMISSION OF THE CITY OF POMPANO BEACH, FLORIDA, APPOINTING ROGER GINGERICH TO THE GOLF ADVISORY BOARD OF THE CITY OF POMPANO BEACH TO FILL THE UNEXPIRED TERM OF AL SIEFERT; SAID TERM TO EXPIRE OCTOBER 24, 2021; PROVIDING AN EFFECTIVE DATE.

(Fiscal Impact: N/A)

PLEASE REFER TO FILE ID NO 2021-612 FOR APPLICANTS.

(Staff Contact: Asceleta Hammond)

A motion was made by Vice Mayor Perkins, seconded by Commissioner McGee, that the Regular Agenda/ Resolution be ADOPTED and to insert the name ROGER GINGERICH. Commissioner Floyd nominated Roger Gingerich. The motion carried unanimously.

Enactment No: RES. No. 2021-229

27. [21-622](#) A RESOLUTION OF THE CITY COMMISSION OF THE CITY OF POMPANO

BEACH, FLORIDA, APPOINTING LEE A. CORSON TO THE MARINE ADVISORY BOARD OF THE CITY OF POMPANO BEACH TO FILL THE UNEXPIRED TERM OF JOHN R. CHAPMAN, ALTERNATE 2; SAID TERM TO EXPIRE ON JULY 1, 2022; PROVIDING AN EFFECTIVE DATE.

(Fiscal Impact: N/A)

APPLICANTS:

Carlton Gillespie - District 1

Corey Staniscia - District 1

Eve Lewis - District 3

Gwendolyn S. Leys - District 3

Lee A. Corson - District 5

(Staff Contact: Asceleta Hammond)

A motion was made by Vice Mayor Perkins, seconded by Commissioner McGee, that the Regular Agenda/ Resolution be ADOPTED and to insert the name LEE A. CORSON. Mayor Hardin nominated Gwendolyn S. Leys and Commissioner McGee nominated Lee A. Corson. The motion carried by the following vote:

Yes: Floyd

McGee

Perkins

Hardin

No: Eaton

McMahon

Enactment No: RES. No. 2021-230

28. [21-623](#) A RESOLUTION OF THE CITY COMMISSION OF THE CITY OF POMPANO BEACH, FLORIDA, APPOINTING JOAN KOVAC TO THE PLANNING AND ZONING BOARD/LOCAL PLANNING AGENCY OF THE CITY OF POMPANO BEACH; FOR A TERM OF THREE (3) YEARS; SAID TERM TO EXPIRE ON JUNE 1, 2024; PROVIDING AN EFFECTIVE DATE.

(Fiscal Impact: N/A)

APPLICANTS:

Joan Kovac, **Incumbent** - District 1

Justin Cromartie - District 1

Lisa Ferreri - District 1

Carlton Gillespie - District 1

Keriann Worley - District 1

Eve Lewis - District 3

Carmen Jones - District 4

Marcus A. McDougle - District 4
 Tony Parrish - District 4
 Andy Cherenfant - District 5
 Daniel P. Diaz - District 5
 Luciene Gomes - District 5
 Linda H. Jones - District 5
 Darlene Smith - District 5
 Dedrick Watkins - District 5

(Staff Contact: Asceleta Hammond)

A motion was made by Vice Mayor Perkins, seconded by Commissioner McGee, that the Regular Agenda/ Resolution be ADOPTED and to insert the name JOAN KOVAC. Commissioner Eaton nominated Joan Kovac. The motion carried unanimously.

Enactment No: RES. No. 2021-231

29. [21-624](#) A RESOLUTION OF THE CITY COMMISSION OF THE CITY OF POMPANO BEACH, FLORIDA, APPOINTING DARLENE SMITH TO THE PLANNING AND ZONING BOARD/LOCAL PLANNING AGENCY OF THE CITY OF POMPANO BEACH, AS ALTERNATE 2, FOR A TERM OF THREE (3) YEARS; SAID TERM TO EXPIRE ON JUNE 1, 2024; PROVIDING AN EFFECTIVE DATE.

(Fiscal Impact: N/A)

PLEASE REFER TO FILE ID NO 21-623 FOR APPLICANTS.

(Staff Contact: Asceleta Hammond)

A motion was made by Vice Mayor Perkins, seconded by Commissioner McGee, that the Regular Agenda/ Resolution be ADOPTED and to insert the name DARLENE SMITH. Mayor Hardin nominated Darlene Smith, Commissioner Floyd nominated Linda Jones and Commissioner McGee nominated Keriann Worley. The motion carried by the following roll call vote:

Yes: Eaton
 McMahan
 Hardin

No: Floyd
 McGee
 Perkins

Enactment No: RES. No. 2021-232

30. [21-625](#) A RESOLUTION OF THE CITY COMMISSION OF THE CITY OF POMPANO

BEACH, FLORIDA, APPOINTING VELMA FLOWERS TO THE RECYCLING AND SOLID WASTE COMMITTEE OF THE CITY OF POMPANO BEACH FOR A TERM OF TWO (2) YEARS; SAID TERM TO EXPIRE ON MAY 14, 2023; PROVIDING AN EFFECTIVE DATE.

(Fiscal Impact: N/A)

APPLICANTS:

Velma Flowers, **Incumbent** - District 4
 Janice Griffin, **Incumbent** - District 3
 Alice Chattman, **Incumbent** - District 4
 Keith Haag, **Incumbent/Alt.1** - District 1
 Brooke Johnston - District 1
 Tanya Manfredi - District 1
 Mary Lou Ruderman - District 1
 Eve Lewis - District 3
 Dedrick Watkins - District 5

(Staff Contact: Asceleta Hammond)

A motion was made by Vice Mayor Perkins, seconded by Commissioner McGee, that the Regular Agenda/ Resolution be ADOPTED and to insert the name VELMA FLOWERS. Vice Mayor Perkins nominated Velma Flowers. The motion carried unanimously.

Enactment No: RES. No. 2021-233

31. [21-626](#) A RESOLUTION OF THE CITY COMMISSION OF THE CITY OF POMPANO BEACH, FLORIDA, APPOINTING JANICE GRIFFIN TO THE RECYCLING AND SOLID WASTE COMMITTEE OF THE CITY OF POMPANO BEACH; FOR A TERM OF TWO (2) YEARS; SAID TERM TO EXPIRE ON MAY 14, 2023; PROVIDING AN EFFECTIVE DATE.

(Fiscal Impact: N/A)

PLEASE REFER TO FILE ID NO 2021-625 FOR APPLICANTS.

(Staff Contact: Asceleta Hammond)

A motion was made by Vice Mayor Perkins, seconded by Commissioner McGee, that the Regular Agenda/ Resolution be ADOPTED and to insert the name JANICE GRIFFIN. Vice Mayor Perkins nominated Janice Griffin. The motion carried unanimously.

Enactment No: RES. No. 2021-234

32. [21-627](#) A RESOLUTION OF THE CITY COMMISSION OF THE CITY OF POMPANO BEACH, FLORIDA, APPOINTING ALICE CHATTMAN TO THE RECYCLING AND SOLID WASTE COMMITTEE OF THE CITY OF POMPANO BEACH; FOR A TERM OF TWO YEARS; SAID TERM TO EXPIRE ON MAY 14, 2023; PROVIDING AN

EFFECTIVE DATE.

(Fiscal Impact: N/A)

PLEASE REFER TO FILE ID NO 2021-625 FOR APPLICANTS.

(Staff Contact: Asceleta Hammond)

A motion was made by Vice Mayor Perkins, seconded by Commissioner McGee, that the Regular Agenda/ Resolution be ADOPTED and to insert the name ALICE CHATTMAN. Vice Mayor Perkins nominated Alice Chattman. The motion carried unanimously.

Enactment No: RES. No. 2021-235

33. [21-628](#) A RESOLUTION OF THE CITY COMMISSION OF THE CITY OF POMPANO BEACH, FLORIDA, APPOINTING KEITH HAAG TO THE RECYCLING AND SOLID WASTE COMMITTEE OF THE CITY OF POMPANO BEACH, AS ALTERNATE 1, FOR A TERM OF TWO (2) YEARS; SAID TERM TO EXPIRE ON MAY 14, 2023; PROVIDING AN EFFECTIVE DATE.

(Fiscal Impact: N/A)

PLEASE REFER TO FILE ID NO 2021-625 FOR APPLICANTS.

(Staff Contact: Asceleta Hammond)

A motion was made by Vice Mayor Perkins, seconded by Commissioner McGee, that the Regular Agenda/ Resolution be ADOPTED and to insert the name KEITH HAAG. Vice Mayor Perkins nominated Keith Haag. The motion carried unanimously.

Enactment No: RES. No. 2021-236

34. [21-629](#) A RESOLUTION OF THE CITY COMMISSION OF THE CITY OF POMPANO BEACH, FLORIDA, APPOINTING DEDRICK WATKINS TO THE RECYCLING AND SOLID WASTE COMMITTEE OF THE CITY OF POMPANO BEACH AS ALTERNATE 2, FOR A TERM OF TWO (2) YEARS; SAID TERM TO EXPIRE ON MAY 14, 2023; PROVIDING AN EFFECTIVE DATE.

(Fiscal Impact: N/A)

PLEASE REFER TO FILE ID NO 2021-625 FOR APPLICANTS.

(Staff Contact: Asceleta Hammond)

A motion was made by Vice Mayor Perkins, seconded by Commissioner McGee, that the Regular Agenda/ Resolution be ADOPTED and to insert the name DEDRICK WATKINS. Commissioner Floyd nominated Dedrick Watkins. The motion carried unanimously.

Enactment No: RES. No. 2021-237

35. [21-630](#) A RESOLUTION OF THE CITY COMMISSION OF THE CITY OF POMPANO BEACH, FLORIDA, APPOINTING **MARCUS A. MCDOUGLE** TO THE UNSAFE STRUCTURES AND HOUSING APPEALS BOARD OF THE CITY OF POMPANO BEACH AS MASTERS OF SOCIAL WORK; FOR A TERM OF THREE (3) YEARS; SAID TERM TO EXPIRE ON JUNE 22, 2024; PROVIDING AN EFFECTIVE DATE.

(Fiscal Impact: N/A)

APPLICANTS:

Marcus A. McDougle, **Incumbent/Masters of Social Work** - District 4

Whitney Anne Metevia, **Incumbent/Attorney** - District 3

Paul Summa, **Incumbent/Real Estate Appraiser** - District 2

Ghulam "Joe" Usman, **Incumbent/Plumbing Contractor** - Districts 3 & 5

Daniel R. Cogdill, Incumbent/Electrical Contractor - District 2

Dedrick Watkins, **Resident** - District 5

(Staff Contact: Asceleta Hammond)

A motion was made by Vice Mayor Perkins, seconded by Commissioner McGee, that the Regular Agenda/ Resolution be ADOPTED and to insert the name MARCUS A. MCDOUGLE. Vice Mayor Perkins nominated Marcus A. McDougle. The motion carried unanimously.

Enactment No: RES. No. 2021-238

36. [21-631](#) A RESOLUTION OF THE CITY COMMISSION OF THE CITY OF POMPANO BEACH, FLORIDA, APPOINTING **WHITNEY ANNE METEVIA** TO THE UNSAFE STRUCTURES AND HOUSING APPEALS BOARD OF THE CITY OF POMPANO BEACH AS ATTORNEY; FOR A TERM OF THREE (3) YEARS; SAID TERM TO EXPIRE ON JUNE 22, 2024; PROVIDING AN EFFECTIVE DATE.

(Fiscal Impact: N/A)

PLEASE REFER TO FILE ID NO 21-630 FOR APPLICANTS.

(Staff Contact: Asceleta Hammond)

A motion was made by Vice Mayor Perkins, seconded by Commissioner McGee, that the Regular Agenda/ Resolution be ADOPTED and to insert the name WHITNEY ANNE METEVIA. Vice Mayor Perkins nominated Whitney Anne Metevia. The motion carried unanimously.

Enactment No: RES. No. 2021-239

37. [21-632](#) A RESOLUTION OF THE CITY COMMISSION OF THE CITY OF POMPANO

BEACH, FLORIDA, APPOINTING PAUL SUMMA TO THE UNSAFE STRUCTURES AND HOUSING APPEALS BOARD OF THE CITY OF POMPANO BEACH AS REAL ESTATE APPRAISER; FOR A TERM OF THREE (3) YEARS; SAID TERM TO EXPIRE ON JUNE 22, 2024; PROVIDING AN EFFECTIVE DATE.

(Fiscal Impact: N/A)

PLEASE REFER TO FILE ID NO 21-630 FOR APPLICANTS.

(Staff Contact: Asceleta Hammond)

A motion was made by Vice Mayor Perkins, seconded by Commissioner McGee, that the Regular Agenda/ Resolution be ADOPTED and to insert the name PAUL SUMMA. Vice Mayor Perkins nominated Paul Summa. The motion carried unanimously.

Enactment No: RES. No. 2021-240

38. [21-633](#) A RESOLUTION OF THE CITY COMMISSION OF THE CITY OF POMPANO BEACH, FLORIDA, APPOINTING GHULMAN "JOE" USMAN TO THE UNSAFE STRUCTURES AND HOUSING APPEALS BOARD OF THE CITY OF POMPANO BEACH AS PLUMBING CONTRACTOR; FOR A TERM OF THREE (3) YEARS; SAID TERM TO EXPIRE ON JUNE 22, 2024; PROVIDING AN EFFECTIVE DATE.

(Fiscal Impact: N/A)

PLEASE REFER TO FILE ID NO 21-630 FOR APPLICANTS.

(Staff Contact: Asceleta Hammond)

A motion was made by Vice Mayor Perkins, seconded by Commissioner McGee, that the Regular Agenda/ Resolution be ADOPTED and to insert the name GHULMAN "JOE" USMAN. Vice Mayor Perkins nominated Ghulman Joe Usman. The motion carried unanimously.

Enactment No: RES. No. 2021-241

39. [21-634](#) A RESOLUTION OF THE CITY COMMISSION OF THE CITY OF POMPANO BEACH, FLORIDA, APPOINTING DANIEL R. COGDILL TO THE UNSAFE STRUCTURES AND HOUSING APPEALS BOARD OF THE CITY OF POMPANO BEACH AS ELECTRICAL CONTRACTOR; FOR A TERM OF THREE (3) YEARS; SAID TERM TO EXPIRE ON JUNE 22, 2024; PROVIDING AN EFFECTIVE DATE.

(Fiscal Impact: N/A)

PLEASE REFER TO FILE ID NO 21-630 FOR APPLICANTS.

(Staff Contact: Asceleta Hammond)

A motion was made by Vice Mayor Perkins, seconded by Commissioner McGee, that the Regular Agenda/ Resolution be

ADOPTED and to insert the name DANIEL R. COGDILL. Commissioner McGee nominated Daniel R. Cogdill. The motion carried unanimously.

Enactment No: RES. No. 2021-242

F. NEXT SCHEDULED MEETING

July 13, 2021 at 1:00 p.m. - Regular City Commission Meeting

July 19, 2021 at 9:00 a.m. - City Commission Budget Workshop

July 27, 2021 at 6:00 p.m. - Regular City Commission Meeting

G. REPORTS

Greg Harrison, City Manager - Birthday Wishes - Mr. Harrison announced that Mayor Hardin's Birthday will be on June 25, 2021. Everybody gave a round of applause in expression of best wishes for a Happy Birthday.

Trash Collection Report - Mr. Harrison reported on all the debris removal activity that was carried out from the grid that he mentioned at the last Commission meeting. The event took place on June 10, 2021. As indicated previously, the grid would be from Atlantic Boulevard to NW 15th Street, and west of Dixie Highway to I-95. Approximately 1,000 flyers were distributed to the residents in the targeted areas and on the day of the event 5 Broward Sheriff's Office (BSO) officers, 4 Code Compliance Officials, 4 City bulk trucks, and 6 City staff with 7 daily laborers provided ground litter removal. Teams were created to remove materials and enforce various code issues. Approximately 184 cubic yards of bulk material was removed, 45 discarded tires were removed and properly disposed. An estimated 12 miles of road had ground litter removed from the right-of-way, and with the support of BSO a homeless camp was removed. In addition, with the assistance of the FEC railroad, materials, construction debris and used tires were removed from the railroad tracks west of Dixie Highway. This was quite a day of cleaning up.

Finally, Mr. Harrison mentioned that they will be establishing grids primarily in the northwest area and this will be done periodically in districts 4 and 5.

July 4th Celebration - Mr. Harrison reminded everybody about July 4, 2021 from 5:30 p.m. to 9:30 p.m. which was communicated by email from Mark Beaudreau's staff. The City Commission need to inform the staff if they will be attending this event.

New Firefighters - Mr. Harrison reported that there are 7 new firefighters that will be starting on June 28, 2021. This is a diverse group that will be going through 2 months of rigorous training before they are assigned to a shift. Kudos to the Fire Department and the Human Resources Department for accomplishing this especially with all the restrictions in place due to the pandemic situation.

City Manager's Office Correction of Record - Mr. Harrison noted that he wanted to correct the record one more time. Therefore, he invited Ms. Wegman to come to his office and he will take her to the workstation, where the young lady that sent the information out on the day in question, and she will be shown what happened on that morning.

Mitchell Moore Orange Bowl Project - Mr. Harrison responded to Vice Mayor Perkins comments made earlier regarding her displeasure of the way he handled the Mitchell Moore Orange Bowl project. He indicated that he has to balance the way he works with all six members of the Commission. The Orange Bowl Committee asked the team to keep the Agreement confidential until their signatures were received and put on line, which happened on the same Thursday that he called all six members during the day. He said he cannot have pets among the Commission, so he must treat each one equally. He mentioned that he was sorry that Vice Mayor Perkins' feelings got hurt. He thought when he had mentioned this deal to Vice Mayor Perkins that day, she was very happy about it. In sum, he stated it is a balancing act that City Managers must do from time to time, especially with land acquisition items or legal agreements like this one. In the end, he was just trying to be fair with all six persons on the Commission.

Nesting of Least Tern Birds - Mr. Harrison mentioned that the Least Tern birds are on the City's beach and came all the way from South America. They have chosen a small section of the beach to build their nest in the sand. The beautiful birds are "adorning the beach" at this time. They will be here for approximately 90 days total, and then they will fly back to South America. The nests are located north of the pier and there is a roped off area to protect the birds.

Utilities Awards - Mr. Harrison stated that the Utilities Department received 1 national award and 2 state awards.

A. Randolph Brown, Utilities Director, displayed a glass award that they received from the Water Reuse Association, which is a national award. It is called the Community Water Champion. It recognizes that utilities that ensure a safe, reliable water supply through the development of water recycling treatment facilities and infrastructure. Awardees are in the category that showcase exemplary water reuse project systems and facilities to demonstrate the value of water reuse to the community served by them.

The next award is from the Florida Water Environment Federation called the David York Award. This honors utilities, their commitment and accomplishments in developing, utilizing, and maintaining exemplary reuse programs. The other state award is the City's public education award for "I can Water" from the Florida Water Environment Federation. This award recognizes organizations, campaigns or events for significant accomplishments that foster and support the development of public outreach programs.

Finally, Mr. Brown thanked the City Commission for their support and his staff's hard work.

Mayor Hardin thanked Mr. Brown for these outstanding accomplishments. He stated that the reuse facility has put the City on the map nationally and probably internationally. Mr. Brown is doing great work with his Department and Mayor Hardin encouraged him and his staff to continue to keep up the good work, as they are being recognized.

Mark Berman, City Attorney - No Report.

Asceleta Hammond, City Clerk- No Report.

Commissioner Rhonda Eaton - Cresthaven Civic Association Meeting - Comr. Eaton gave a shout out to Horacio Danovich for attending the Cresthaven Civic Association meeting. She stated that they will not meet again until September, however, it was good to start the ball rolling again.

Additionally, Comr. Eaton thanked Major Wayne Adkins for his Lieutenants, Deputies and especially Sergeant Squadrico who did a great presentation on traffic and traffic calming such as speed bumps and all that it entails. Also, Mario Sotolongo in Code Compliance who had two representatives there. It was nice to get back into the swing of things and to get back to normalcy.

Commissioner Cyndy Floyd - Women's Empowerment Symposium - Comr. Floyd thanked everyone who participated in the Women's Empowerment Symposium on June 12, 2021. This was a successful event. She thanked Kappa Alpha Psi and Kappa Foundation of Pompano Beach, Broward Health, Carol Powell Phillips and all of the magnificent ladies who took part and helped to make the day a great success. In addition, she thanked Mayor Hardin, Comr. McGee, Comr. Eaton and everyone who shared in the wonderful experience she had on this day.

Commissioner Andrea McGee - Parks & Recreation Programs - Comr. McGee congratulated the Parks and Recreation for bringing back all the events on line.

Dune Re-nourishment - Comr. McGee thanked Youth Environment Alliance and the Audubon Society for their efforts. She reported that there were two more weekends of dune re-nourishment and sea oat planting so the beach is looking great. Part of the proof that the system is coming back are the new visitors to the beach, the Least Tern birds.

Parking Requirements in the City - Comr. McGee requested that the Building Department take a good look at the Parking requirements for both residential and commercial buildings, and a reflection of the way in which the residents are living today. Additionally, to look at what the City is projecting for the next 30-40 years, to ensure the City is creating Live - Work environments so people can get to work and get to where they need to be, and as much alternative transportation is being provided. In the commercial aspect, to ensure the requirements considering what tenants are demanding for their spaces. She hopes the Building Department will come back with some recommendations to increase the parking livability standard.

Mayor Hardin suggested that the Commission ask City Manager Harrison to get his staff to brief the Commission on what other communities have in place and to discuss this on a one on one before they "craft something." In sum, to get more direction from the Commission as to where they may want to go on this.

Comr. McGee agreed to a one on one discussion with staff and the Commission to get something started in that direction.

Pompano Beach History - Comr. McGee thanked Comr. McMahon for bringing the books on Pompano's history to the Commission's attention and asked where can residents find these.

Comr. McMahon responded that they are listed on pompanohistory.com or at the museum.

Commissioner Tom McMahon - Renovation of the 5th Avenue Bridge - Comr. McMahon echoed some of the sentiments expressed earlier. The G.O. Bond team and Horacio Danovich has done a great job. The 5th Avenue bridge is a hot topic but they have done a great job in communicating with the residents. He received an email today in reference to somebody that was very vocal about the bridge, who commented on how a particular problem was resolved quickly.

Traffic Issues in Old Pompano - Comr. McMahon commented on the traffic in the Old Pompano neighborhood. He indicated that as the City moves forward with the changes on Atlantic Boulevard, it is important to see how that will impact Snug Harbor in Old Pompano. He is unsure of what the steps will be, but there is a need to ensure that counters are placed where they need to be, as well as making sure traffic is not diverted into the neighborhood as these changes are made on Atlantic Boulevard.

Vice Mayor Beverly Perkins - Improved Communications with City Manager - Vice Mayor Perkins stated that all she wants City Manager Harrison to do is to do his job. She mentioned that she does not want to be his pet. Moreover, she is a grown woman and he did not hurt her feelings, and she does not want to be treated special. She reiterated that all she is requiring is to be informed about what is going on in her district before decisions are made with staff behind the scene. She stated that she does not have to provide her input or her opinion, all she needs is to be informed. Vice Mayor Perkins mentioned that she was not only referring to the incident with the football field, because it is more to it than that. She stated that there are a lot of things going on in her district that she hears from other people that starts in City Hall and she receive the back end of it all the time. Therefore, when she is contacted and asked about something happening in her district her response is that she does not know anything about it.

Juneteenth National Independence Day - Vice Mayor Perkins reported that the Senate passed a resolution last Tuesday, establishing June 19th as Juneteenth National Independence Day. This is a United States holiday collaborating the end of slavery in the United States.

Mayor Hardin agreed that this is indeed historic news for the Country.

Mayor Rex Hardin - Residential District Advisory Board Meeting - Mayor Hardin pointed out to everybody and all interested parties, the community, and the residents that Broward County will be holding a meeting of the Residential District Advisory Board on Tuesday, July 13, 2021 at 6:30 p.m. at the Larkins Center. He mentioned that the Residential District Advisory Board is a board that is going to make recommendations to the Broward County Commission about a \$10 million pot of money that the County Commission has control of to spend in the Northwest area. It has to be spent in the residential areas. This was part of the negotiated settlement of a lawsuit that the City was involved with the County concerning the Community Redevelopment Agency (CRA).

The District Advisory Board will be meeting together to get public input, which they will make a

recommendation eventually to the full County Commission on how that \$10 million should be spent. Anyone who is interested in this matter and would like to share their opinion about what should happen to the \$10 million and how to spend it in the Northwest residential areas, besides just saying, "I want a check" he recommended these residents show up at the meeting on Tuesday, July 13, 2021 at 6:30 p.m. at the E. Pat Larkins Community Center. Furthermore, he indicated that he has some ideas and he will be attending. He is looking forward to the meeting, as well as for the dispersal of those dollars, which has been sitting in the County's coffers. They have not been doing the job that they should have been doing for the residents in the City of Pompano Beach for a few years. These funds do not accrue interest.

Finally, Mayor Hardin stated that the Advisory Board consists of County Commissioners Lamar Fisher, Mark Bogen, Dale Holness, plus other people from the community to include Pastor Stanley and Corey Thompson.

Mark Berman stated that based on the interest for attending the July 13 meeting he will be posting with the Clerk a notice as a public meeting, since it appears that it will be more than one City Commissioner in attendance.

Commendation of Former Firefighter Rob Brantley - Mayor Hardin reported that he received a letter from Jim Vandron, the Secretary of the Fort Lauderdale Fire and Safety Museum, Inc., located in Fort Lauderdale. Within the letter Mr. Vandron extolled the virtues of one of the City's former retired firefighters Rob Brantley, who is a gem, and lives in the City with his wife Aletta. He plays a significant part in keeping the City's antique fire engines running. He is so dedicated to that mission that he actually helps out with other organizations, and this is what the letter is about. They are saying thank you to Rob and they wanted to send a letter to the Mayor of the City to inform us of all the stuff that is going on out there, where dedicated former employee in the City of Pompano Beach, Rob Brantley does to assist other fire departments and fire museums. So, hats off to Rob, thanks for all that he does and it is recognized by the City and other cities.

H. ADJOURNMENT

The meeting adjourned at 9:28 p.m.

DocuSigned by:
Asceleta Hammond
775D4290316A490...
Asceleta Hammond, City Clerk

DocuSigned by:
Rex Hardin
502CB780EB3F480...
Rex Hardin, Mayor



EXHIBIT 1

Mitchell Moore Park Orange Bowl Committee Cooperation Agreement

June 22, 2021

Agenda Item 9 (21-646)

Cooperation Agreement - Basic Terms

Charitable Contribution \$1,500,000.00

- New Press Box and Seating
- Shade Upgrades
- Refurbish Two Existing Buildings
- Enhanced Walking Trail
- Field Maintenance Program - Maintenance Plan
- Soft Costs (legal, ribbon cutting ceremony, theming, OBMM third party oversight, contingency)
- Scoreboard Enhancements for Visibility from I-95
- Other

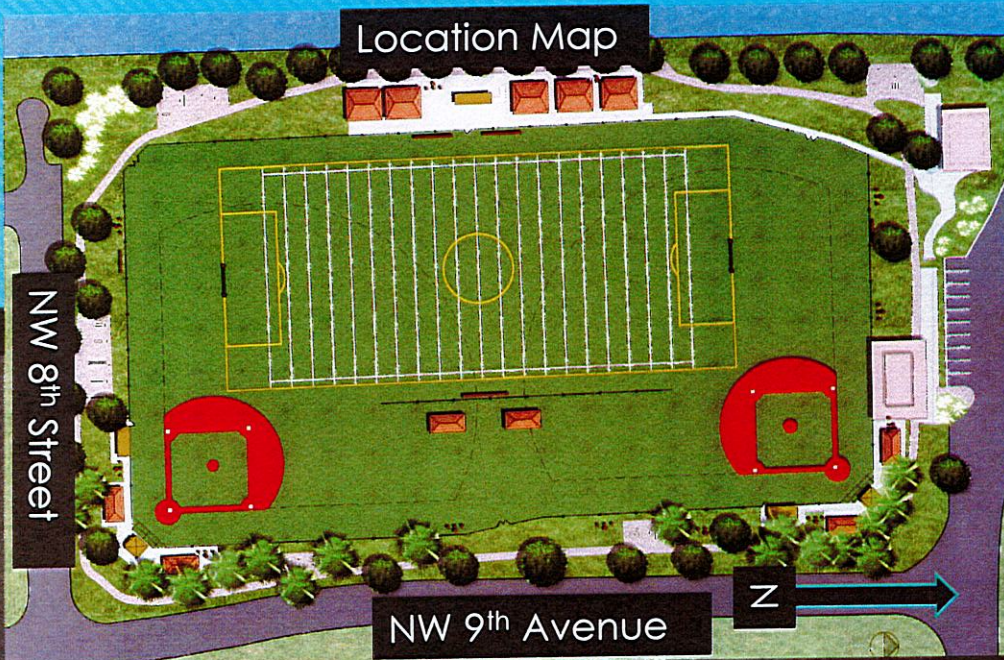

Preferred Model Transportable

Proposed Bleachers



Proposed Exercise Equipment



New Scoreboard



Proposed Scoreboard (Equal or Similar to McNair Park but Elevated to Be Seen from I-95)

Carl Lee Jefferson

CARL LEE JEFFERSON

1930-2012



Carl Jefferson was an icon in the Northwest Pompano Community for over forty years. He first volunteered as a baseball coach for Westside Park in the 1950's. During this time, every young male in Pompano who was inspired to play baseball came through Mr. Jefferson's training. Carl Jefferson was a teacher at Blanche Ely High School, where he also served as a baseball coach; he later became an Administrator for Ely High School. After retirement, Mr. Jefferson became very instrumental in the development of youth baseball and T-ball programs at Mitchell/Moore Park

August 16, 2007

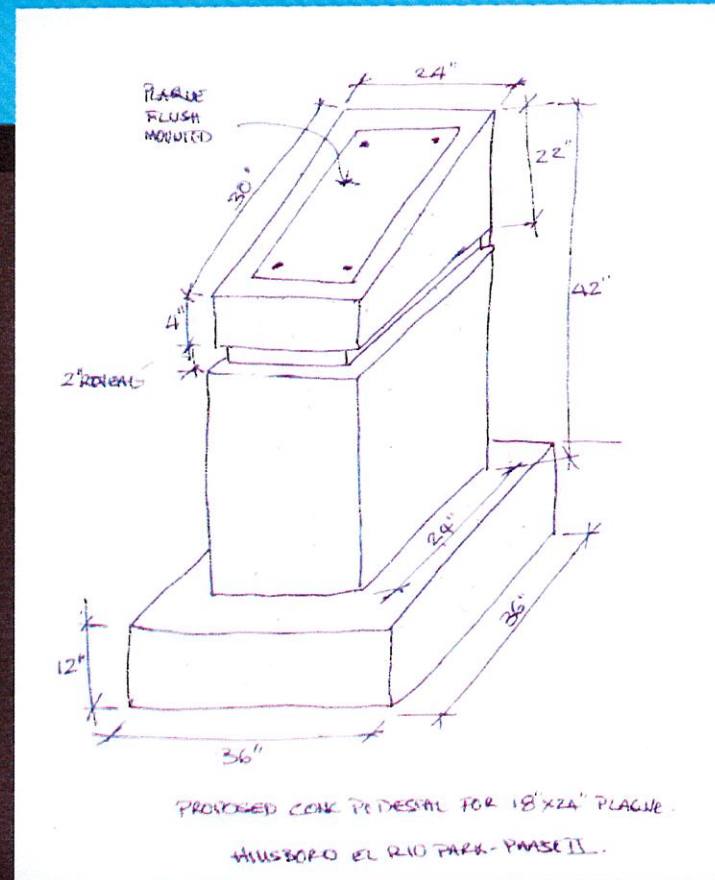



The American Rescue Plan Act ("ARPA") 2021 Proposed Allocation Plan



City of Pompano Beach
City Commission Meeting
June 22, 2021

American Rescue Plan Act (“ARPA”)

1. Passed March 11, 2021 – 3rd Covid-19 Stimulus package
2. Eligible expenditures:
 - Public Health Emergency: *vaccinations, testing, PPEs, etc.*
 - *Respond to Negative Economic Impacts – individual and small business assistance.*
 - Government Services – *replace calculated revenue losses*
 - Infrastructure – broadband, water & sewer, health services...
3. Expenditures from March 3, 2021 (except for rental, small business, etc.).
4. Funds to be committed by December 31, 2024 & Expended by December 31, 2026.

State and Local Fiscal Recovery Fund

Type	Amount (\$ billions)
States & District of Columbia	\$195.3
Counties	\$65.1
Metropolitan Cites	\$45.6
Tribal Governments	\$20.0
Territories	\$4.5
Non-entitlement Local Government	\$19.5

Pompano Beach ARPA Allocation

May 2021 Distribution Received	\$ 12,847,029
May 2022 Expected Distribution	12,847,029
Total City ARPA Allocation	25,694,057
Plus Estimated Interest Income	150,000
Total ARPA Funds	\$ 25,844,057

Public Health Emergency Response

Resident Vaccination Incentive Program (\$100 Publix gift card)	\$ 3,250,000
Personal Protective Equipment/Sanitizing	150,000
Covid-19 Testing	50,000
Public Awareness/Advertising	100,000
Emergency Operations Center/Logistics Warehouse Enhancements	\$ 2,200,000

Community Response & Resiliency

Rental Assistance	\$ 1,162,445
Water & Sewer Utility Bill Assistance	1,000,000
Affordable Housing - Single Family	1,000,000
Affordable Housing - Multi-family	680,000
Housing Rehabilitation - Wind Mitigation	1,000,000
Homeless Prevention Landlord Recruitment	250,000

Community Response & Resiliency

Summer Camp/Childcare Scholarships	\$ 250,000
Youth Educational Workspaces (computers, internet)	100,000
Mitchell Moore Park Youth Annex Bldg. Improvements	400,000

Economic Stabilization and Recovery

Small Business Relief Program	\$ 2,500,000
Workforce Development - Train to Gain Hospitality & Culinary Program	200,000
Water Taxi Subsidy	650,000

General Government Services (replace covid-19 revenue losses)

Public Safety Services	\$ 10,326,612
Tourism/Hospitality Promotions	250,000
Community Theater/Playwright Residency Program	50,000
Arts Unplugged Program	25,000
Events/Festivals Restart	\$ 250,000

Accountability

- Special Revenue Fund – Segregation of funds
- Quarterly Project and Expenditure Reports
- Funds subject to annual financial audit by an independent CPA
- Funds subject to a Single Audit Grant audit by an independent CPA

QUESTIONS?