

Site Data

| | | | |
|-------------------------|--|-----------------|-----------------|
| APPLICATION NAME | 2131 BLOUNT ROAD | | |
| APPLICATION NUMBER | SP-1-1 | | |
| ZONING | I-1 COMMERCIAL | | |
| EXISTING USE | COMMERCIAL | | |
| PROPOSED USE | COMMERCIAL | | |
| FUTURE LAND USE | 60 | | |
| LOCATION: | 2131 BLOUNT ROAD, POMPAÑO BEACH, FLORIDA | | |
| SECTION TOWNSHIP RANGE | | | |
| TAZ | | | |
| PCN | 48-42-28-09-0142 | | |
| GROSS SITE AREA: | 1.56 ACRES | 67,850 S.F. | 100 % |
| TOTAL IMPERVIOUS AREA: | 1.24 ACRES | 53,797.6 S.F. | 79.3 % |
| BUILDING COVERAGE: | .74 ACRES | 32,174.2 S.F. | 47.4 % |
| EXISTING BUILDING: | 21,680.2 S.F. | | |
| PROPOSED EXPANSION: | 9,937.3 S.F. | | |
| EXISTING COVERED AREA: | 556.7 S.F. | | |
| PAVEMENT AND SIDEWALK: | .50 ACRES | 21,623.4 S.F. | 31.9 % |
| TOTAL PERVIOUS AREA | .32 ACRES | 14,052.4 S.F. | 20.7% |
| OPEN AREAS: | | | |
| GROSS FLOOR AREA: | 31,617.5 S.F. | | |
| PARKING REQUIRED: | 17 SPACES | | |
| USE | REQUIREMENT | SPACES REQUIRED | SPACES PROVIDED |
| WHOLESALE: | 31,617.5 S.F. 1 SPACE PER 750 for first 3,000 S.F. | 4 SPACES | 4 SPACES |
| | 1 SPACE PER 2500 S.F. | 13 SPACES | 18 SPACES |
| TOTAL PARKING PROVIDED: | 22 SPACES | | |

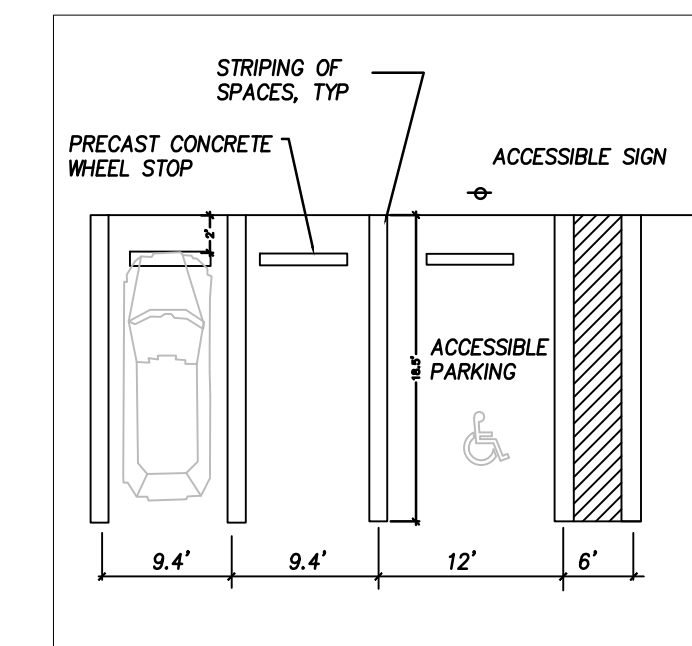

Parking Detail NTS

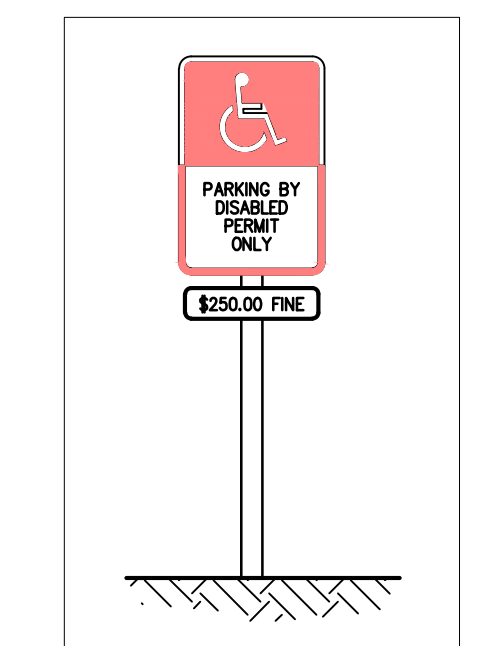

H/C Sign NTS

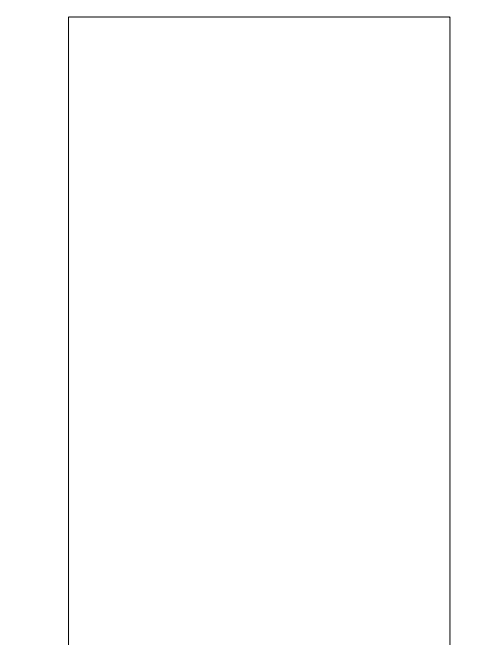

Sign Detail NTS

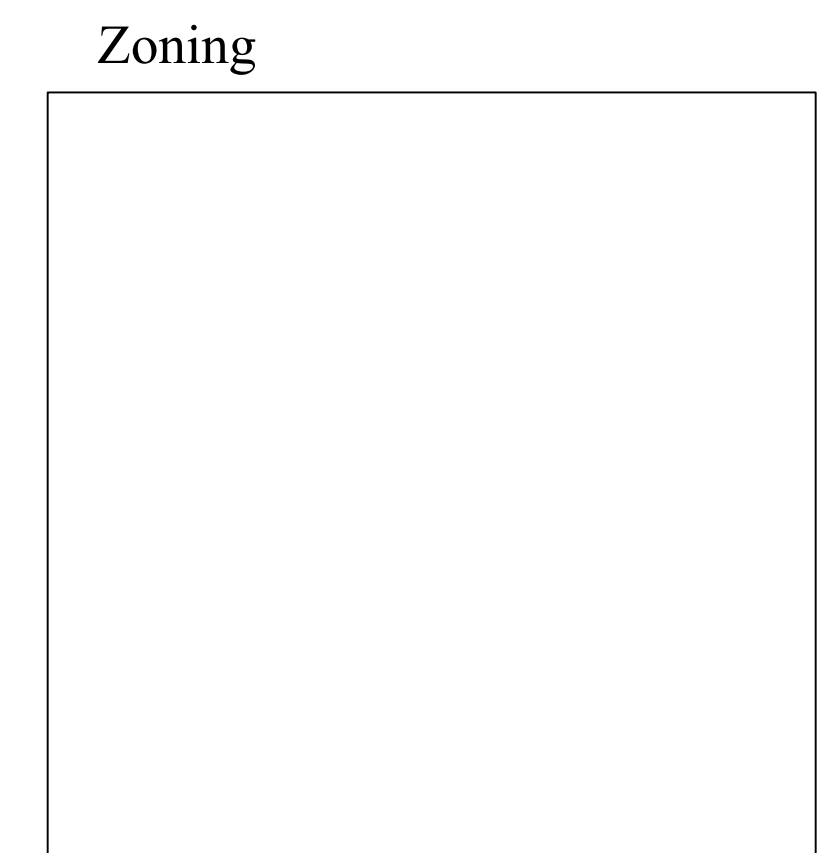

Frogner Consulting, LLC
 3402 SE Club House Place
 Stuart, Florida 34997
 Phone: (561-386-3035)
 Email: jfrogner@comcast.net

BLOUNT ROAD

2131 Blount Road, Pompano Beach Fla.

SITE PLAN

| | |
|------------|-------------------------|
| Job Name: | BLOUNT ROAD SITE PLAN |
| CADD File: | BLOUNT ROAD SP BASE.DWG |
| Date: | 11.21.23 |
| Drawn By: | DLN |
| Comments: | PREL SITE PLAN |
| | 11.28.23 |
| | DLN |
| | PREL SP2 |

Debra L. Northsea
 Landscape Architect
 6008 Eagles Nest Drive
 Jupiter, Florida 33458
 Phone: (561-758-6739)
 Email: DLN.LANDSCAPE@outlook.com
 Fla. Registration #1521

