

Exhibit C

- SCOPE OF WORK:**
- REMOVE DOCK AND PILINGS
  - REPLACE WITH NEW PVC DOCK
  - (3) NEW 10" PILINGS
  -

**DOCK/SEAWALL PLANS**

PREPARED FOR:  
**Pelloni, Vollman  
&  
Sulflow Marine**  
271 GOOLSBY BLVD.  
DEERFIELD BEACH, FL 33442

PROJECT:  
Mike Lepera  
1101 SE 6th Terrace  
Pompano Beach, FL 33060

12/5/18



MARK E. WEBER, P.E.  
LICENSE #53895  
MW ENGINEERING, INC.  
CA # 30702  
8810 NORTH STATE ROAD 7  
COCONUT CREEK, FL 33073  
WWW.MxEngineering.net

PAGE 1

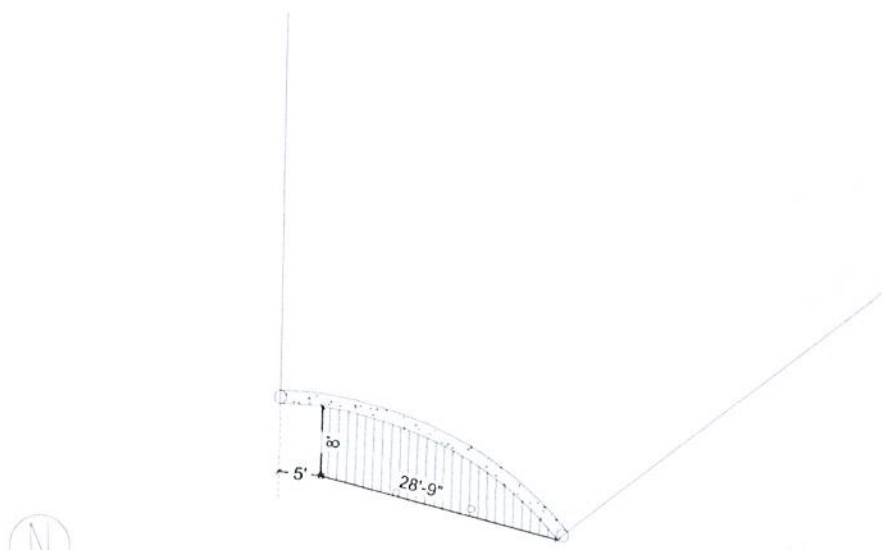

**SITE PLAN**  
SCALE: 1/16" = 1'-0"

CANAL

SEE SURVEY FOR  
ADDITIONAL PROPERTY INFORMATION

ORIGINAL

ORIGINAL

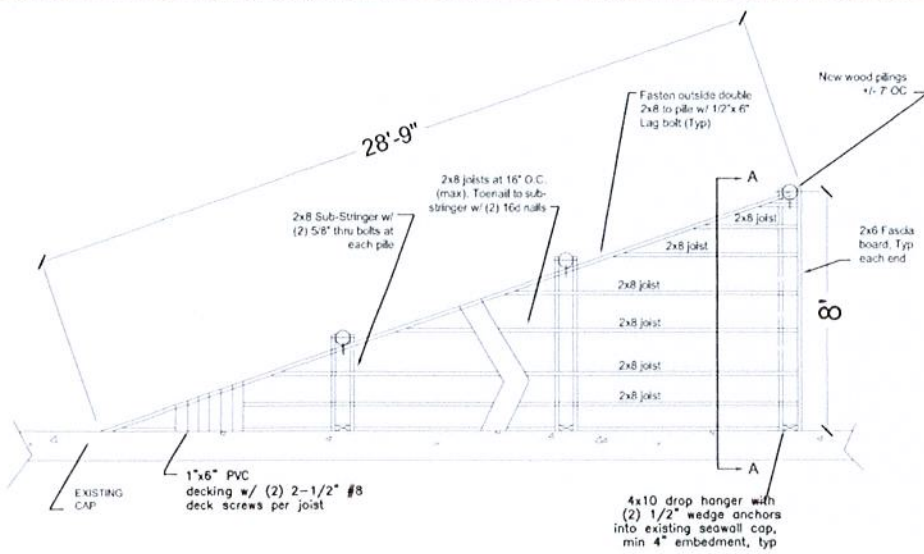

**Dock Framing Plan**

Scale: NTS

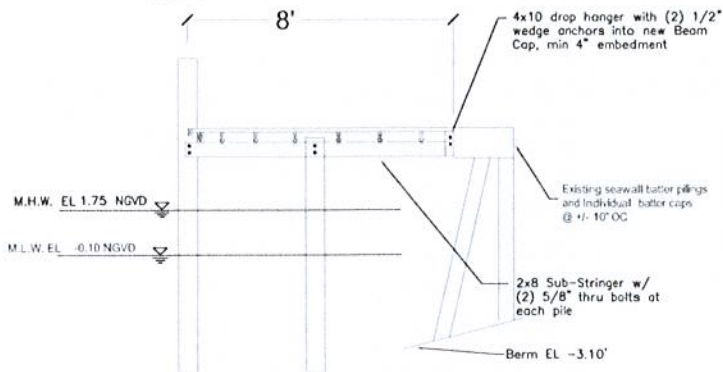

**Dock Section A-A**

Scale: NTS

**General Notes:**

- Licensed Contractor shall verify the existing conditions prior to commencement of the work. Any conflicts or omissions between existing conditions or the various elements of the working drawings shall be brought to the attention of the Engineer prior to the commencement of the work. The Licensed Contractor and all subcontractors are responsible for all lines, elevations, and measurements.
- Do not scale drawings for dimensions.
- All unanticipated or unforeseen demolition and/or new construction conditions which require deviation from the plans and notes herein shall be reported to the Engineer prior to commencement of work.
- Licensed Contractor to verify location of existing utilities prior to commencing work.
- The Licensed contractor to install and remove all shoring and bracing as required for the proper execution of the work.
- Licensed Contractor to obtain all permits as necessary from all Local, State, and Federal agencies.
- All framing materials to be pressure treated, southern pine, grade 2 or better, min. Fb = 1450 psi or better.
- All hardware to be galvanized or stainless steel.
- All piles to be driven to a min. of 8' or refusal into strata to a min. bearing capacity of 10 tons.
- Elevations shown are based on the national geodetic vertical datum of 1929, for NAD 88 add 1.5'.
- Design in accordance with 2017 Florida Building Code 6th Ed.

**DOCK/SEAWALL PLANS**

PREPARED FOR:

**Pelloni, Vollman  
&  
Sulflow Marine**

271 GOOLSBY BLVD.  
DEERFIELD BEACH, FL 33442

PROJECT:

Mike Lepera  
1101 SE 6th Terrace  
Pompano Beach, FL 33060

12/5/18



MARK E. WEBER, P.E.  
LICENSE #53895  
MW ENGINEERING, INC.  
CA # 30702  
6810 NORTH STATE ROAD 7  
COCONUT CREEK, FL 33073  
WWW.MwEngineering.net